

JEEP ELECTRIC WINDOWS

Cherokee
Wagoneer

DESCRIPTION

System consists of an electrically operated tailgate window and individual motors at all side windows. Tailgate window operates on two circuits: an instrument panel switch or an external key switch at tailgate. Side windows are operated by individual switches at each door, or by a complete set of control switches at the instrument panel.

Electric tailgate window system consists of a safety switch, gearbox-type regulator, 12 volt DC motor, wiring and connections and a 30 amp. circuit breaker at fuse block. Electric side window system consists of regulator motors, switches, actuators and actuator rods, wiring and connections and a 30 amp. circuit breaker located at the fuse block.

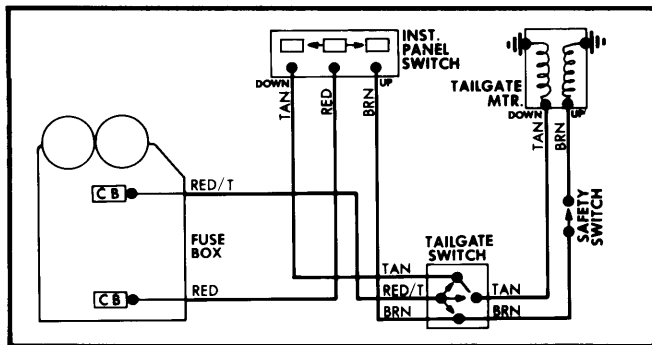

Fig. 1 Jeep Instrument Panel Tailgate Wiring Diagram Cherokee & Wagoneer

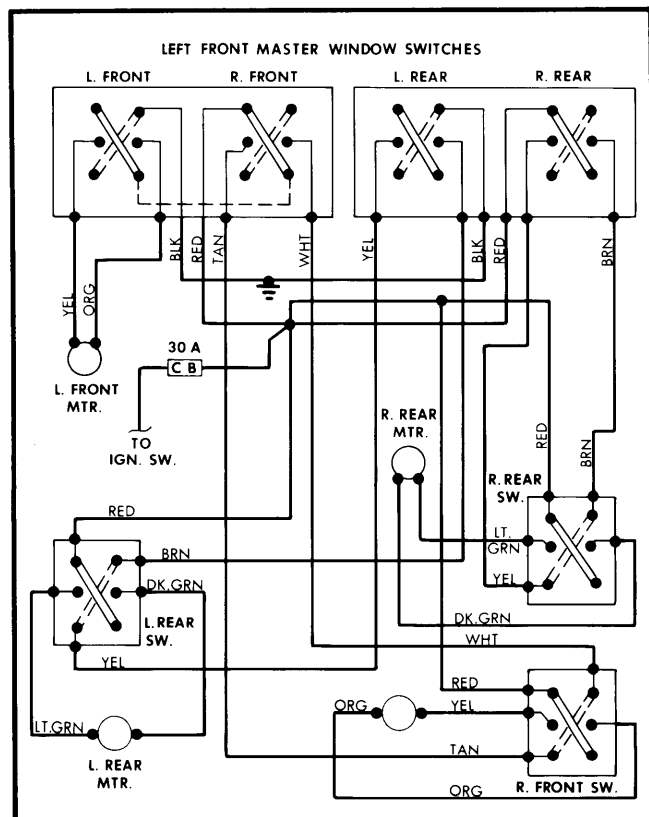

Fig. 2 Jeep Power Window Wiring Diagram

TESTING

INSTRUMENT PANEL & TAILGATE SWITCH

Turn ignition switch to "ON" position. Using a 12 volt test lamp or a voltmeter, connect one end of test equipment to ground and probe the "RED" lead. If current is not available, repair feed circuit. If current is present, probe "BROWN" lead with switch in "UP" position. If current is present move switch to "DOWN" position and check the "TAN" lead for current. If current is not present, replace switch. If current is present check window switch in the tailgate using the same procedure.

NOTE — If vehicle is equipped with a tailgate window defogger, the defogger and tailgate switches are serviced as one assembly. Both switches must be replaced when either is defective.

TAILGATE WINDOW SAFETY SWITCH

Using a 12 volt test lamp or a voltmeter, place window switch in "UP" position and check "BROWN" lead for current. If current is not present, repair feed circuits. If current is present, close safety switch and check lead at motor. If current is present check motor ground. Motor is grounded through "BLACK" lead at instrument panel switch. If motor is properly grounded and system does not operate, replace motor. If current is not present, replace safety switch.

TAILGATE WINDOW MOTOR

Using a 12 volt test lamp or a voltmeter, connect one lead of test equipment to ground and probe "TAN" lead. Close safety switch and turn tailgate window switch to "DOWN" position. If current is not present, repair feed circuit. Probe "BROWN" wire at motor, close safety switch and place switch in "UP" position. If current is not present, repair feed wire. If current is present in both tests but motor does not operate, replace motor.

MASTER SWITCH CIRCUITS

1) Remove escutcheon and housing from master switch. Separate terminal plate by releasing retainer hooks to expose terminal ends.

2) Turn ignition switch to "ON" position. Using a 12 volt test lamp, connect one lead to black wire and other lead to red terminal. Repeat test at second black wire.

3) If lamp does not light in either test, remove black lead and connect to chassis ground. If lamp lights, an opening exists between master switch and ground. If lamp does not light, it indicates a defective circuit breaker or an opening in the red wire from circuit breaker to master switch.

CONTROL SWITCH & MOTOR CIRCUITS

1) Connect test lamp between terminals of "ORANGE" and "YELLOW" wire. Operate control switch "UP" and "DOWN".

2) If lamp lights in both positions, wires and door switch are not defective. Disconnect "WHITE" and "GREEN" motor leads at terminal plate and connect to "GREEN" and "WHITE" leads.

3) Operate master switch. If window goes up and down, motor is okay, but switch is defective. If motor does not

JEEP ELECTRIC WINDOWS (Cont.)

operate, check connections and leads to motor. If motor operates, switch is defective.

SIDE WINDOW MOTOR

Connect test battery positive lead to one of the motor terminals. Connect negative lead to other terminal. Motor should now rotate in one direction to go "UP" or "DOWN".

SWITCH VOLTAGE TEST

1) Connect one lead of a jumper wire to "RED" lead, and the other lead to "UP" terminal of switch. Connect one lead of a second jumper wire to ground terminal of switch and other lead to "DOWN" terminal. This will test "UP" operation of switch.

2) If motor runs, voltage is present to motor. Connect switch to multiple connector and operate switch. If motor fails to run, replace switch. Test all switches in this manner.

3) To test "DOWN" operation of switch, make connections as stated in step 1) except connect second lead of first jumper wire to "DOWN" terminal, and second lead of second jumper wire to "UP" terminal. Repeat tests on all switches. Results are the same as "UP" test.

REMOVAL & INSTALLATION

TAILGATE WINDOW REGULATOR & MOTOR

1) Remove carpet and tailgate access cover plate. Remove retainers attaching regulator arms to channel. Disengage regulator arm pins from channel and raise glass.

2) Carefully support glass in raised position. If regulator attaching screws are covered by sector gears, disconnect motor drive from gear regulator. Grasp regulator arm as far outboard as access hole will allow.

3) Push down on arm until holes in sector gears align with attaching screws and motor. Hold regulator in this position and wedge a 1/4" screw between meshing teeth. Remove regulator attaching screws, regulator and motor. Release spring tension by using a large screwdriver to snap spring from under tension bracket.

4) To install, reverse removal procedure.

SIDE WINDOW MASTER SWITCH

1) Disconnect negative battery cable. Remove retaining screws and escutcheon. Remove switch housing screws.

2) Pull switch out to expose wires. Disconnect terminal plate from switch. Depress retainer clips through holes in switch housing and remove switch.

FRONT & REAR DOOR REGULATORS & MOTORS

1) Raise window half way up. Disconnect negative battery cable. Remove door trim panel and water shield.

2) Insert a drift punch into hole in door inner panel, or use masking tape to hold window half way up. Remove regulator arm retainer clip and remove arm from bottom window channel.

3) Disconnect wires from motor. Remove nuts and bolts from inner door panel-to-regulator and remove regulator and motor assembly.

4) To install, reverse removal procedures.

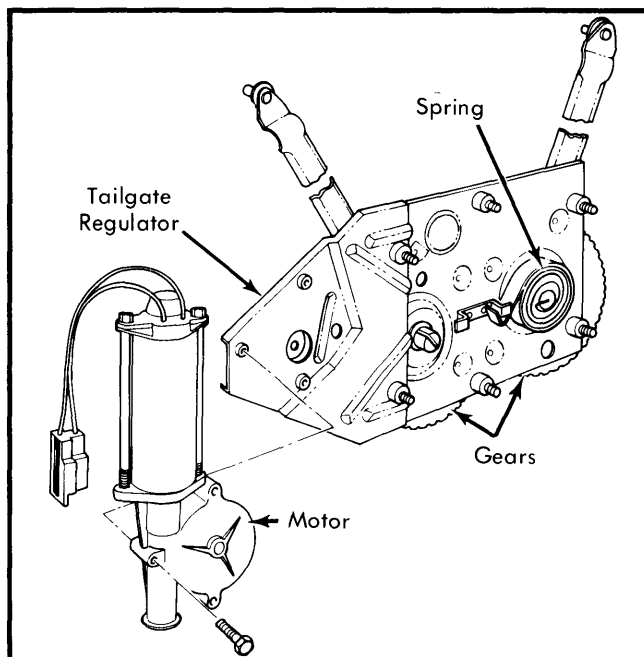

Fig. 3 Power Tailgate Regulator and Motor