

FORD SIDE WINDOWS

**Bronco
"F" Models**

DESCRIPTION

Ford power window system consists of reversible 12 volt motors in each front door, switches to operate motors, wiring harness and necessary connections. Driver's door has a multiple switch to control both windows.

REMOVAL & INSTALLATION

MOTORS

1) Disconnect battery cable. Remove door trim panel. Disconnect power window motor wire from harness connector. Using a $\frac{1}{2}$ " diameter drill bit, drill 2 holes in door inner panel at drill dimples located opposite 2 unexposed motor drive retaining screws.

NOTE — Check before drilling to make sure no wires are in line with holes to be drilled.

2) Remove 3 motor mount retainer screws using 2 drilled holes and existing access holes. Push motor outward to disengage motor and drive from rectangular gear. After motor and drive are disengaged, prop window up. Remove motor and drive.

3) To install, reverse removal procedure, noting the following: Tighten screws to 50-85 INCH lbs. Cover drilled holes with suitable body tape. Ensure that door drain holes are open.

POWER WINDOW SWITCH

1) Insert a thin screwdriver between bezel and trim panel at either side of bezel. Carefully pry bezel from trim panel and housing assembly will snap out. On left side switch, remove 2 retaining screws from bottom side of connector. Unsnap right side connector from housing.

2) Pry switch from connector with a small screwdriver. To install, position switch in connector and press firmly. Reverse removal procedure to complete installation.

SWITCH CONNECTOR WIRE

If replacement of a switch wire or switch connector is necessary, insert a needle-like tool into edge of pin hole and bend terminal in. Pull wire and terminal from connector. To install terminal in connector, open terminal and insert it in connector.

TESTING

MOTOR

1) Remove motor and drive assembly from vehicle. Connect a power source (battery or power-pac) to motor with an ammeter in series. Operate motor and observe current draw.

2) Current draw should not exceed 4 amps and should not fluctuate. Reverse motor wire connections to observe reversed motor rotation. Replace motor if current draw exceeds 4 amps.

MULTIPLE SWITCH

1) Remove switch from vehicle. Using an ohmmeter or test light, clip a test probe on pin No. 6 which is grounded. See Fig. 1.

Place both switches in neutral position and test for continuity between pin No. 6 and pins No. 1 through No. 4.

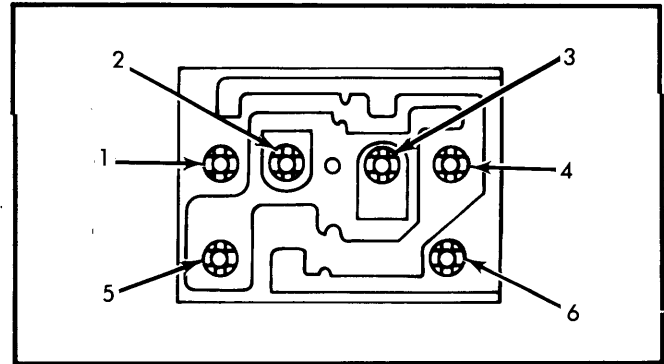

Fig. 1 Multiple Switch Pin Location

2) Push both switches upward. Both No. 1 and No. 3 should lose continuity to pin No. 6. Push switches downward. No. 2 and No. 4 should lose continuity to pin No. 6.

3) Remove test probe from No. 6 and connect to feed pin (No. 5). With both switches in neutral position, no continuity should exist at remaining terminals. Push switches upward. No. 2 and No. 4 should show continuity with No. 5. If any switch does not test as indicated, replace complete switch assembly.

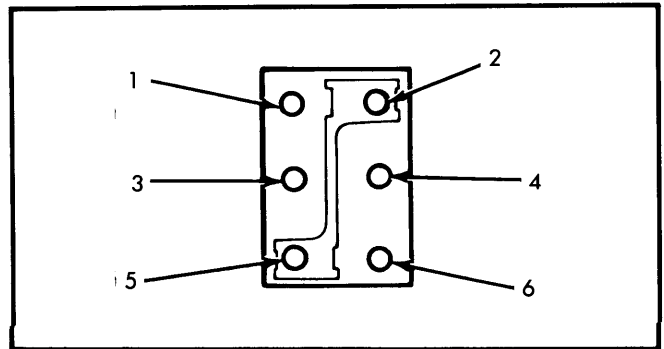

Fig. 2 Single Switch Pin Locations

SINGLE SWITCH

1) With the switch in the neutral position, use an ohmmeter to test switch. Continuity should exist between terminals 1, 2, 3, and 5. Continuity should also exist between 4 and 6. See Fig. 2.

2) With switch pushed downward, continuity should exist between 2, 4 and 5. Continuity should also exist between 1 and 3. Terminal 6 should be disconnected from all other terminals.

3) With switch pushed upward, there should be continuity between terminals 2, 3, and 5; also 4 and 6. Terminal 1 should be disconnected from all other terminals. If switch does not operate as indicated in any test, replace switch.