

FORD

All Models

DESCRIPTION

Power rearview mirror assemblies consist of door-mounted mirrors with internal motor drive and backing plate. System includes a door panel switch and necessary wiring components.

TROUBLE SHOOTING & TESTING

ONE MIRROR DOES NOT FUNCTION

1) Working underneath mirror, remove head of plastic rivet using a $\frac{1}{4}$ " drill. Remove rivet stem remnants. Remove screw from cover, remove cover and disconnect plug. Check function of mirror by connecting 12 volts to terminals of wire plug. Yellow and Green wires provide up-down movement; Black and White wires, right-left movement.

2) If mirror does not function, replace motor drive. See *Motor Drive Removal in this Article*. If mirror functions when tested, but does not operate when connected to feed wire, remove left door panel and test feed wire for continuity at switch plug. Then, apply 12 volts to feed wire. If mirror functions through feed wire, but fails to respond to switch operation, replace switch.

BOTH MIRRORS DO NOT FUNCTION

1) Remove left door inner trim panel. Unplug accessory feed wire (Black and Yellow with Red stripe) and check for voltage. Turn ignition switch to "ON" position on "E" models. If no voltage is observed, remove instrument panel on "E" models or instrument panel pad on "F" models. Check hot wire, in-line fuse, and ground connections. Repair as necessary.

2) If voltage is present at accessory feed wire plug, reconnect wire and check mirror functions. If satisfactory, install trim panel. If no voltage is observed, disconnect and check continuity of wiring, step-by-step, from hot wire lead to cowl/door harness connection, to switch wire feed connection, and to mirror feed wire connection. Replace or repair damaged wiring.

REMOVAL & INSTALLATION

MIRROR GLASS & MOTOR DRIVE

Removal — Break out and remove center of mirror glass and expose mounting screw attaching backing plate to motor drive. See Fig. 1. Remove and discard mirror remnants and backing plate, saving 3 stabilizer bars. Remove 4 screws attaching motor drive to mirror assembly. See Fig. 1. Unplug wires from motor drive by pushing connector retainer tab, separating connectors. Remove motor drive assembly.

Installation — Connect wiring connector to motor drive assembly. Insert stabilizer bars into motor drive. See Fig. 2. Install new backing plate to motor drive with center screw, and snap stabilizer ball joints in sockets of backing plate. Install motor drive/backing plate assembly to bracket and tighten screws. Remove paper backing from new mirror replacement glass, and press firmly into backing plate.

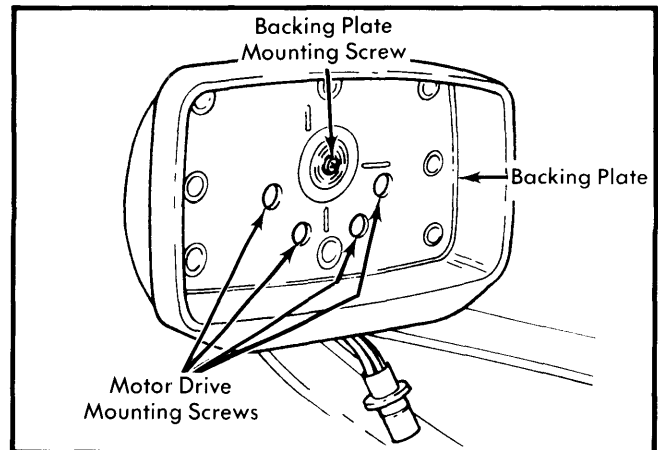

Fig. 1 Electric Mirror Mounting Screws

MIRROR ASSEMBLY

Removal — Using a $\frac{1}{4}$ " drill bit, remove head of plastic rivet securing cover on mirror assembly. Remove rivet stem remnants. Remove screw from cover, and remove cover. Disconnect electrical connector. Remove screws attaching mirror assembly to door, and remove mirror assembly.

Installation — To install, reverse removal procedure.

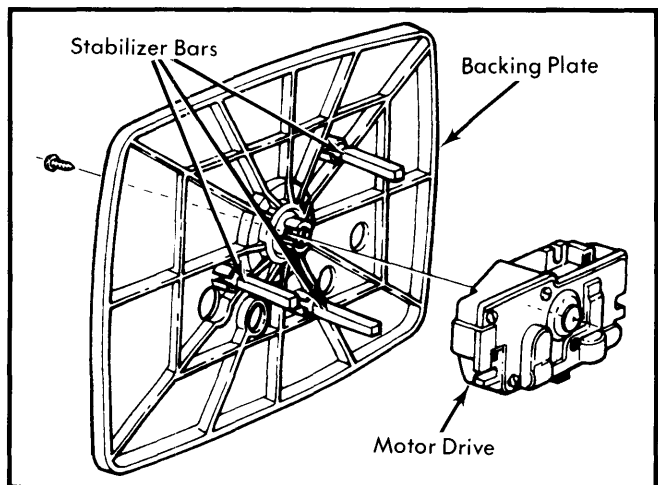

Fig. 2 Motor Drive Stabilizer Bars

MIRROR SWITCH ASSEMBLY

Removal & Installation — Remove left door inner trim panel. Disconnect wiring harness from both switch wiring assemblies. Remove 2 bezel nuts securing bezel and switch assembly to door. Remove bezel and switch from door. To install, reverse removal procedure.

NOTE — Some "F" models may use a snap-in bezel-switch assembly. Insert screwdriver in slots at bezel edge to release retention springs. Then, disconnect wiring harness from switch, loosen set screw, and remove switch.