

GENERAL MOTORS – MOTOR ACTUATED

**Chevrolet
GMC**

DESCRIPTION

The electric door lock system consists of a lock actuator assembly at each door, conventional switches and a relay. All doors lock and unlock manually or from the door control switches. All components are serviced as complete assemblies. The motor is a permanent magnet, 12 volt reversible type that is protected by an internal circuit breaker which may require 1 to 3 minutes to reset. A 30 ampere circuit breaker also protects the door lock feed circuit to relay wiring. The relay assembly is a double-pole, double-throw relay externally grounded to body beneath the right side of the instrument panel behind glove compartment. The control switch is a three-pin rocker type mounted on door armrests. The feed circuit to the lock switches is protected by a 20 ampere fuse.

TROUBLE SHOOTING

DOOR LOCKS INOPERATIVE FROM BOTH CONTROL SWITCHES, COURTESY LAMP FUSE BLOWN

Install new courtesy lamp fuse and press door lock switch to "Lock" position. If fuse blows, check for short in Light Blue wire between relay and switches. If system remains operative, check for short in Orange wire and in both Light Blue and Black wires between source and cross bar harness.

DOOR LOCKS INOPERATIVE, COURTESY LAMP OPERATES

With a test lamp grounded, check Orange/Black wire at relay connector. If light remains off, check circuit breaker and circuit to relay. With light on, press switch to lock position. If light remains off, check ground to the body. If grounded, replace relay.

DOORS WILL UNLOCK BUT WILL NOT LOCK

With a test lamp grounded, check Light Blue wire terminal at relay. Press switch to "Lock" position. If light comes on but system does not operate, replace relay. If light does not come on, check for short between relay and cross-body wiring harness.

DOORS WILL LOCK BUT WILL NOT UNLOCK

With a test lamp grounded, check Black wire at relay. Press switch to "Unlock" position. If light comes on but system does not operate, replace relay. If light does not come on, check for open in Black wire between relay and cross-body harness.

DOOR LOCKS OPERATE EXCEPT FOR ONE DOOR

Check for loose connection of Gray and Tan wires, or short in circuit. If both leads check to the actuator motor, replace the motor.

DOOR LOCKS OPERATE NORMALLY EXCEPT ONE DOOR WILL NOT UNLOCK/LOCK

Check ground and if correct, check for open in Light Blue wire between switch and cross-body harness.

DOOR LOCKS INOPERATIVE AND RELAY CLICKS WHEN ACTIVATED

Check Light Blue and Black wires between switch and relay.

DOOR LOCKS INOPERATIVE OR LOCKS PULSATE AND RELAY CHATTERS WHEN SWITCH IS ACTIVATED

Gray and Tan wires are making contact between relay and lock actuator motor.

REMOVAL & INSTALLATION

DOOR LOCK MOTOR

- 1) Disconnect battery cable, remove door trim panel and disconnect electrical connector from motor.
- 2) Remove screws attaching motor to door. Remove door lock lever from rubber mount at top of motor actuator and remove motor through access hole. To install, reverse removal procedure.

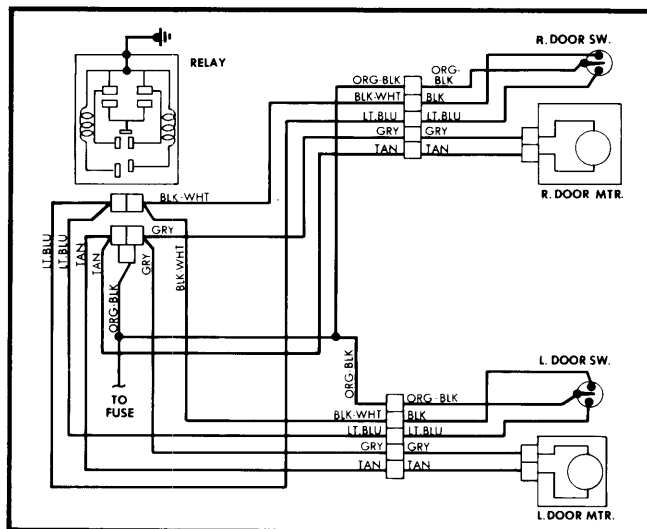

Fig. 1 General Motors Light Truck Power Door Lock Wiring Diagram