

## INTERNATIONAL HARVESTER AUTO-CRUISE

### International Harvester

#### DESCRIPTION

System senses vehicle speed through speedometer cable and uses engine intake manifold vacuum to regulate accelerator and automatically maintain any pre-set cruising speed between 30 and 80 MPH.

#### OPERATION

Auto-Cruise control is an integral part of directional switch lever and consists of two separate switches. The first "OFF-ON" and "RES" (resume) slide switch located on the flat of directional switch lever. Second is a push button switch located at the end of directional switch lever. To engage system, move slide switch to "ON" position and accelerate to desired speed. Depress and release button on end of switch lever. System will automatically disengage when brake pedal is depressed and can be re-engaged to previously selected speed by accelerating to 30 MPH and moving slide switch to "RES" position, then releasing switch.

**NOTE** — When slide switch is moved to "OFF" position, pre-set speed of "RES" function is cancelled and must be reset when system is reactivated.

A higher speed can be set by pressing on accelerator pedal until new speed is reached and then pushing control button. A lower speed can be achieved by lightly depressing brake pedal allowing vehicle to slow to desired speed and then depressing push button. The same effect can be achieved by moving slide switch to "OFF" causing vehicle to slow down. When desired speed is reached, move switch to "RESUME" position. To accelerate for passing, depress accelerator and when passing is completed, remove foot from accelerator and speed will decrease to former level. Operation of individual components is as follows:

**Control Switch** — An integral part of turn signal lever, when actuated it will energize either solenoid valve or coupling coil (or both), thereby controlling speed.

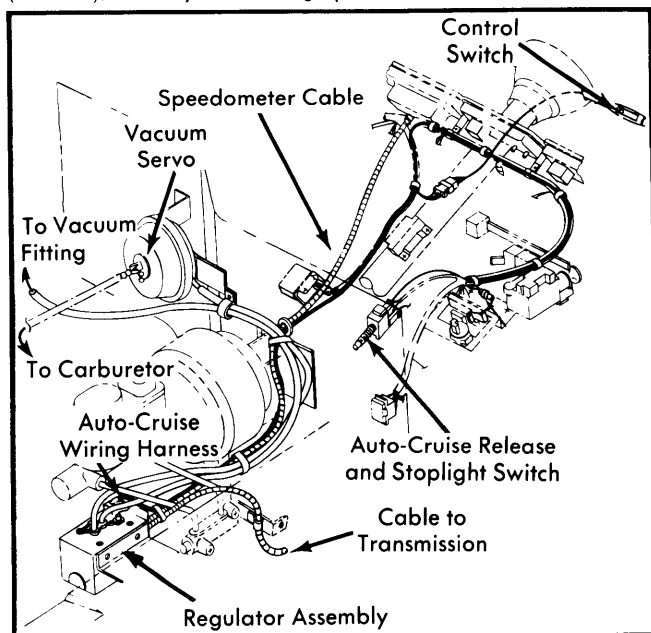

Fig. 1 IHC Auto-Cruise System

**Vacuum Servo** — A neoprene bellows which is used to vary throttle operation in relation to the vacuum supplied to regulator assembly.

**Release Switches (Electric & Vacuum)** — Release switches disengage system when brake pedal is depressed.

**Regulator** — Senses speed through speedometer cable located between transmission and regulator. Fly-weight type governor reacts to cable speed and engages low speed switch at approximately 30 MPH. When low speed switch is closed, driver may engage system. Regulator, which controls amount of vacuum supplied to servo unit, must be serviced as an assembly.

#### TROUBLE SHOOTING & DIAGNOSIS

##### SYSTEM WILL NOT ENGAGE

System harness fuse blown. Defective control switch. No current to brown wire at No. 2 terminal of regulator. Brake switch improperly adjusted. Improper vacuum switch adjustment. Vacuum switch defective. Defective valve body and magnet assembly, or faulty low speed switch requiring regulator replacement.

##### SYSTEM DOES NOT DISENGAGE WHEN BRAKES APPLIED

Defective brake release switch or adjustment is incorrect. Faulty valve body and magnet assembly requiring regulator replacement.

##### CARBURETOR DOES NOT RETURN TO NORMAL IDLE

Improper throttle linkage adjustment. Throttle return spring weak or disconnected. Faulty throttle cable linkage.

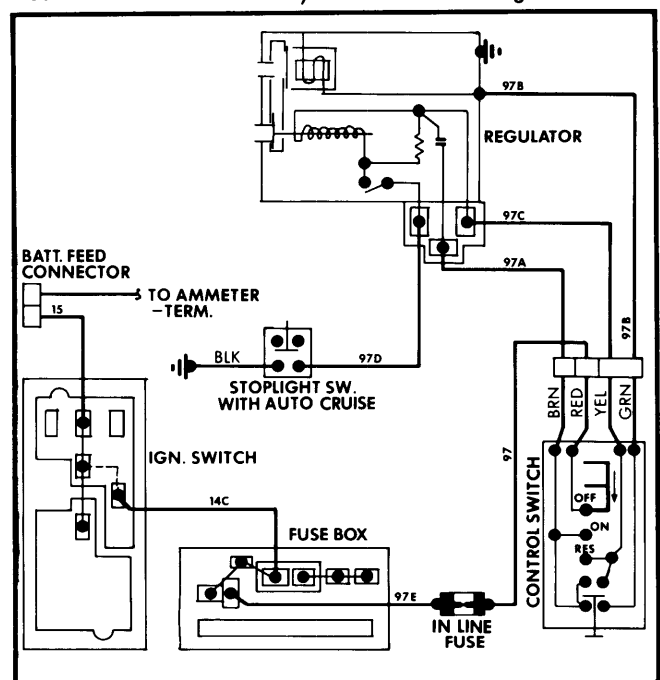

Fig. 2 IHC Auto-Cruise System Wiring Diagram

## INTERNATIONAL HARVESTER AUTO-CRUISE (Cont.)

### PULSATING ACCELERATOR PEDAL

Kinked speedometer or drive cable.

### SPEED 3 OR MORE MPH ABOVE OR BELOW SELECTED SPEED

Incorrect adjustment of regulator centering spring screw.

### SYSTEM WILL NOT CONTROL AT SELECTED SPEED

Faulty vacuum servo or hose. Faulty governor requiring regulator replacement.

## TESTING

### OPERATIONAL TEST

Start engine and operate vehicle on highway. Components should function as stated under *Operation*.

### CONTROL SWITCH CONTINUITY

Control switch continuity test is performed at steering column using an ohmmeter. Refer to the following chart to determine switch continuity condition.

**NOTE**— Pushbutton cannot be depressed with slide switch in "RES" position.

#### Control Switch Continuity Conditions

Application	Switch Position	Condition
Red/Brown	"OFF"	Open
Red/Green	"OFF"	Open
Red/Yellow	"OFF"	Open
Red/Brown	"ON"	Closed
Red/Green	"ON"	Closed
Red/Yellow	"ON"	Open
Red/Brown	"RES"	Closed
Red/Green	"RES"	Closed
Red/Yellow	"RES"	Closed
Red/Brown	"ON"①	Closed
Red/Green	"ON"①	Open
Red/Yellow	"ON"①	Closed

① — Pushbutton is depressed.

## ADJUSTMENT

### CENTERING SPRING

**NOTE**— Adjustment of centering spring is extremely sensitive. Adjustment screw must never be turned more than 1/8 turn in either direction.

Auto-Cruise system is designed to maintain speed designated by driver, within 3 MPH. Speed change is made by adjusting spring centering screw. If speed control holds speed more than 3 MPH above designated speed, turn centering spring screw

"C" toward "S" but only 1/8 turn or less. See Fig. 3. If speed is more than 3 MPH below designated speed, turn the centering spring speed screw "C" toward "F", but only 1/8 turn or less.

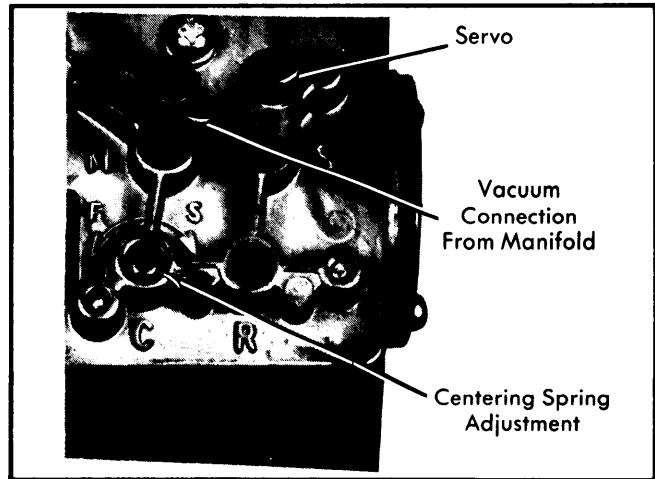

Fig. 3 IHC Centering Spring Adjustment Screw

### VACUUM SERVO-TO-CARBURETOR LINKAGE

Block choke plate in full open position and open throttle slightly to release fast idle cam. Return throttle to curb idle position. With bead chain removed from vacuum servo and cotter pin removed from rear of bead chain cover, check throttle lever-to-servo chain length. Pull chain tight from servo end, without moving throttle lever. Loosen chain by backing off one ball. Manually open throttle so as to attach bead chain to clip in servo. Squeeze clip closed to securely fasten bead chain. Slide chain cover toward servo until two beads are visible between clip and cover. Install cotter pin to secure cover to chain. Reconnect and then unblock choke plate.

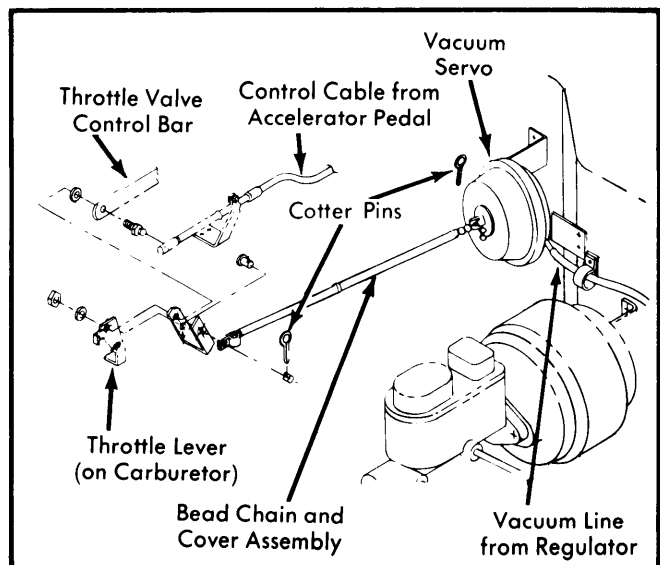

Fig. 4 IHC Auto-Cruise Vacuum-to-Throttle Linkage

### VACUUM & ELECTRIC SWITCHES

Adjust vacuum release valve or electric release switch with brake pedal released so that distance between brake pedal lever and body face is .10".