

## FORD MOTOR CO. TAILGATE WINDOW

## Bronco

## DESCRIPTION

Power tailgate window system consists of a motor and regulator assembly inside the tailgate, a key operated switch at the tailgate, an instrument panel switch, a limit switch to prevent window operation when tailgate is open and all necessary wiring and connections. Circuit is protected by two 25 amp. circuit breakers located in the fuse block. One circuit breaker protects the key switch, and one protects the instrument panel switch.

## REMOVAL &amp; INSTALLATION

## REGULATOR SWITCH &amp; MOTOR

- 1) Remove interior access cover from tailgate. Raise glass to full "UP" position.
- 2) Disconnect wiring harness from switch and/or motor. Remove clip attaching switch to lock cylinder and remove switch. Remove motor mounting screws and remove motor.
- 3) To install, reverse removal procedures making sure to check operation of switch and motor before replacing access cover.

## WINDOW REGULATOR

Raise glass to full "UP" position. Remove screws attaching regulator to tailgate, and remove regulator. To install, reverse removal procedure.

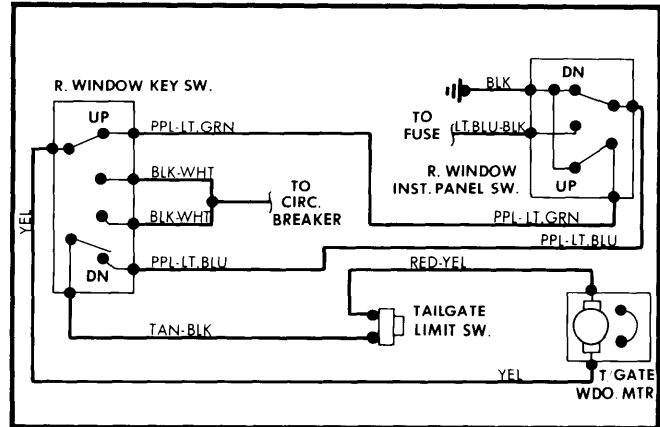

Fig. 1 Ford Bronco Power Tailgate Window Wiring Diagram