

HITACHI ALTERNATORS

International Harvester
6 Cyl. Diesel Models

DESCRIPTION

The alternator is a conventional three-phase, self-rectifying type alternator. Six internal diodes (three positive and three negative) are used to rectify current. The alternator consists of a stator having three windings, a rotor, pulley, end covers to support rotor, brushes and slip rings which supply power to rotor coil.

APPLICATION

Model	Hitachi No.
6 Cyl. Diesel Models	
Standard	LT123-38K
Optional	LT123-64K

SPECIFICATIONS

Alternator Test	Specification
Rated Output	40 Amps
Current Output [ⓐ]	24.5 Amps@14 Volts
No Load Voltage [ⓐ]	13.8-14.8 Volts
Field Attraction Current	Approx. 2.4 Amps
ⓐ — At 2500 maximum alternator RPM.	

TESTING

FIELD ATTRACTION CHECK

To measure the current flowing through field, connect an ammeter into the circuit (see Fig. 1). A reading of approximately 2.4 amperes should be noted.

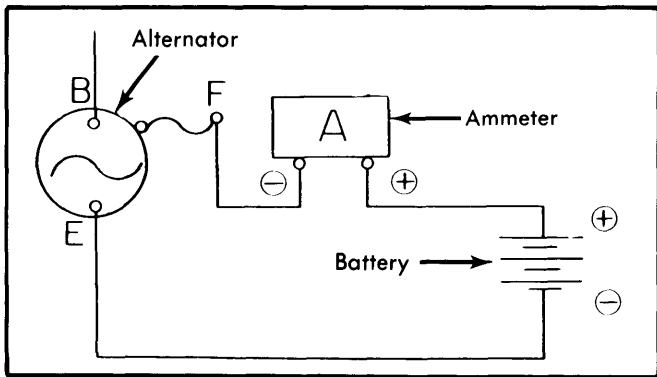

Fig. 1 Measuring Alternator Field Current

DIODE CHECK

Use an ohmmeter to check diodes at alternator connector. Position test leads as shown in following table and results should be as specified in the table. If results are not as specified, disassemble alternator and check diodes.

Diode Continuity Check

Ohmmeter Lead Position		Results
Positive	Negative	
Terminal "A"	Terminal "E"	Continuity
Terminal "E"	Terminal "A"	No Continuity
Terminal "A"	Terminal "N"	Continuity
Terminal "N"	Terminal "A"	No Continuity
Terminal "N"	Terminal "E"	Continuity
Terminal "E"	Terminal "N"	No Continuity

OVERHAUL

DISASSEMBLY

1) Remove nut and take off pulley, fan, and fan base. Remove Woodruff key and spacer for pulley. Remove two attaching screws and brush cover. Remove two screws for brushes and carefully remove brushes. Remove three through bolts and tap alternator using a wooden mallet to separate front and rear.

2) Remove three front bearing retainer screws. Tap front cover from rotor assembly by using a wooden mallet. Remove felt seal. Unsolder lead and diode connections using a 100-200 watt soldering iron and utilizing long nose pliers as a heat sink.

CAUTION — Try to limit time of heat application to 1-2 seconds at a time, as high internal temperatures will destroy diodes.

3) Separate stator from rear cover. Remove two screws attaching SR holder (for diodes) and remove from rear cover. Remove two attaching screws and remove brush holder.

INSPECTION & REPAIR

Rotor — 1) Apply test probes to slip rings of rotor. If continuity does not exist, then rotor coil is open and must be replaced. Apply test probes to slip ring and rotor core to check ground. If continuity exists, replace rotor assembly.

2) Check slip ring diameter and if less than 1.26", replacement of rotor assembly is necessary as slip rings are not serviced separately. Check slip rings for out-of-round using a dial indicator. If out-of-round is greater than .004", rework slip ring. If out-of-round is greater than .012", replace rotor assembly. Check slip ring friction surfaces to ensure they are not dirty or pitted. If necessary, polish surfaces using fine sandpaper.

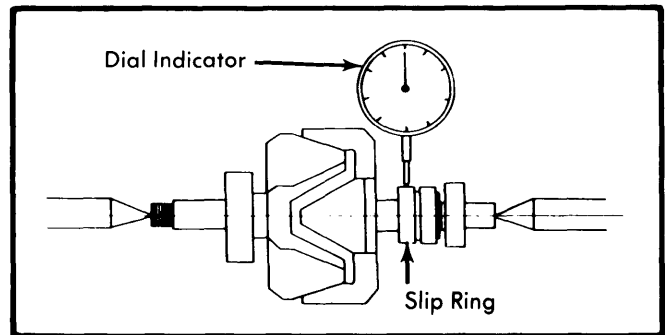

Fig. 2 Checking Slip Ring Out-of-Round

Stator — The stator is normal when there is continuity between individual stator coil terminals. When there is no continuity between terminals, cable is broke and replacement of stator assembly is necessary. If each lead wire of stator coil does not have continuity with stator core, then stator is good. If continuity exists, then stator is grounded and must be replaced.

Diodes — 1) Perform a continuity test on all diodes, in both directions, using an ohmmeter. Test the continuity between each diode and the SR holder or rear cover. If there is continuity in both directions or no continuity in either direction,

HITACHI ALTERNATORS (Cont.)

then diode requires replacement. Continuity should be present in one direction only.

2) To replace a diode, place the diode with the leads facing up and press out using a suitable tool and press. To install, press in while making sure diode is facing the right direction.

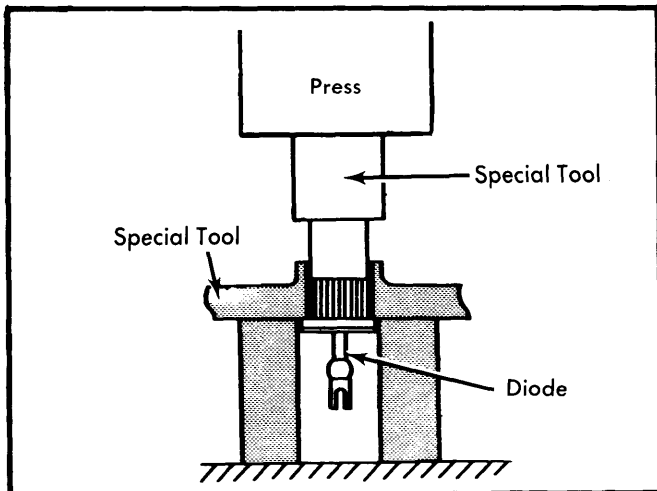

Fig. 3 Removing Alternator Diodes

Brushes & Springs — If brushes have a loose pigtail, uneven wear, or are less than .295" in length, then replacement is necessary. Springs must have tension of .463 lbs. and must not be deformed.

Bearings — If bearings are rough then use a press or bearing puller to remove from the rotor shaft. Press the front bearing onto the rotor shaft to the point at which it contacts the spacer. Press the rear bearing onto shaft until it is .689" from the end of shaft.

REASSEMBLY

Reinstall diode assembly and stator to rear cover. Connect lead wires of stator coil to terminals of diode assembly by soldering. Solder quickly to avoid damaging diodes. Install felt seal and reinstall front cover to rotor. Install front bearing retainer screw and 3 through bolts. Position assembly in vise and install pulley and related components to rotor shaft. Assemble brushes to brush holder and install holder into alternator.

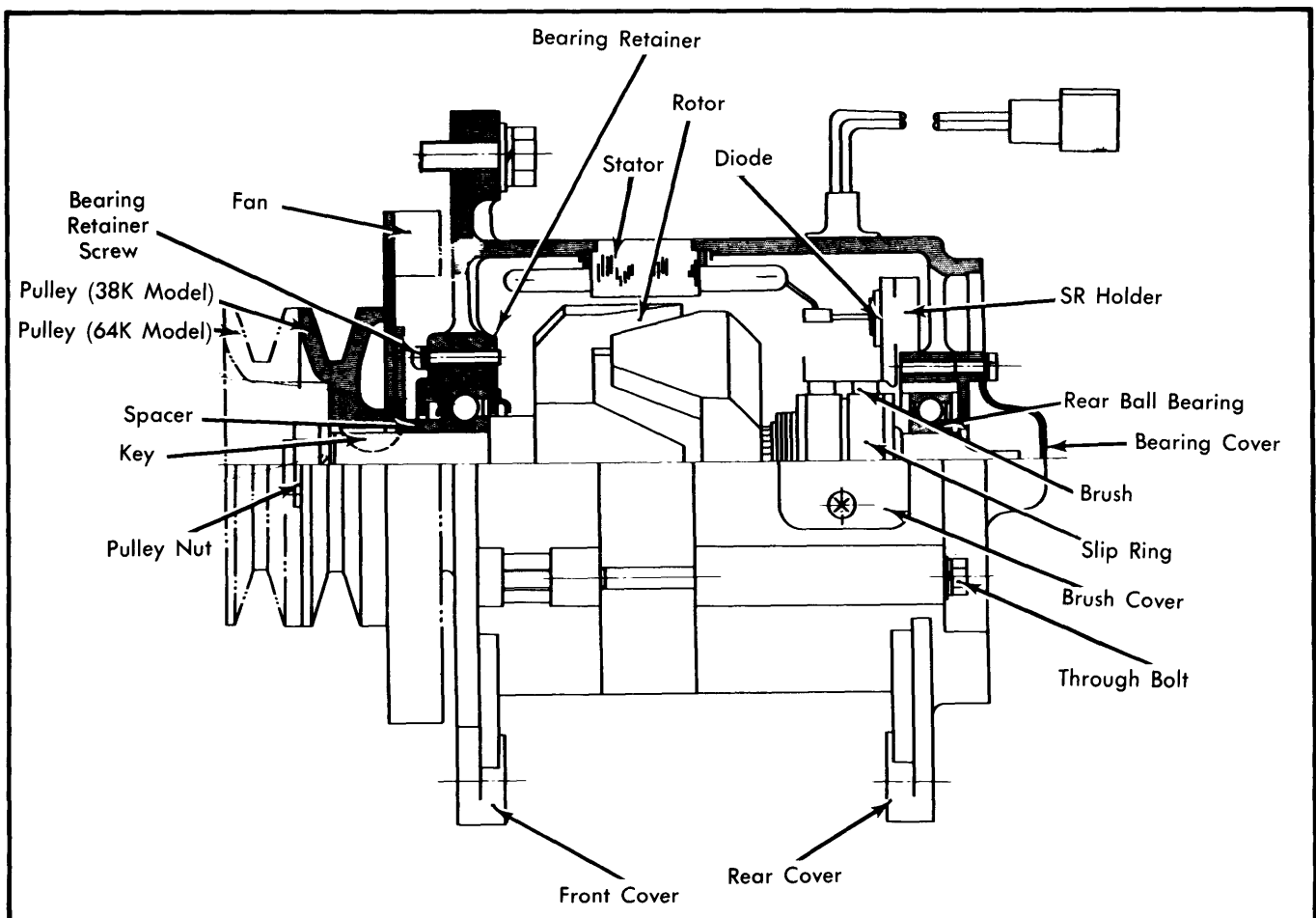

Fig. 4 Component View of Hitachi Alternator