

## FORD MOTOR CO.

### All Models

### DESCRIPTION

Two speed permanent magnet windshield wiper motor is used. The two speed motor uses a three brush plate and switch assembly. When control selector is in low position, grounded brush and white wire brush are used to operate motor at low speed. When control selector is in high position, grounded brush and blue wire brush are used to operate motor at high speed. When control selector is moved to park position, motor will continue at low speed until park switch lower contacts open, stopping motor in park position. Optional interval wipers are available on "E" models, "F" models and Bronco. Intermittent operation is controlled by a variable resistor in the windshield wiper control switch, combined with the electronic governor allows a variable pause between wiping cycles.

For normal operation on "F" models, turn wiper control knob to right for low or high speed. For intermittent operation, rotate wiper control knob to left. The more knob is rotated to left, the greater the time interval between wiper blade sweeps. On "E" models the wiper switch knob slides toward the right with the first position being intermittent, the second is low and the third is high. As the control is moved to the left of intermittent position the interval between blade sweeps is at a maximum and as it moves to the right of intermittent detent, the blade sweep interval is reduced.

### TESTING

#### WIPER MOTOR CURRENT DRAW

**"E" Models** — Disconnect linkage from motor and use suitable connector sleeves (kit no. C4AZ-14294-B or equivalent) between motor terminals and a volt-amp meter. Connect positive (red) lead from meter to center terminal on motor end plate and green lead from meter to battery positive post. Connect a jumper wire from negative post of battery to low speed terminal on motor end plate and check current draw. Move jumper wire from low speed to high speed terminal and check current draw. Current draw should not exceed 3.5 amperes. If current draw is excessive, check output arm and windlatch mechanism for binding or damage before replacing motor. See Fig. 1.

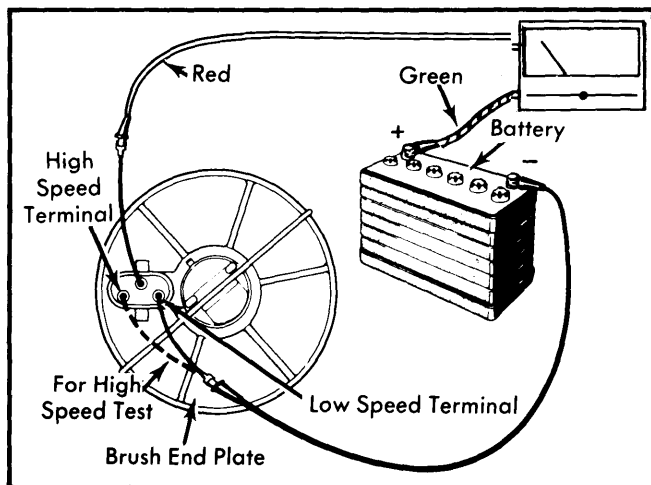

Fig. 1 Motor Current Draw Test "E" Models

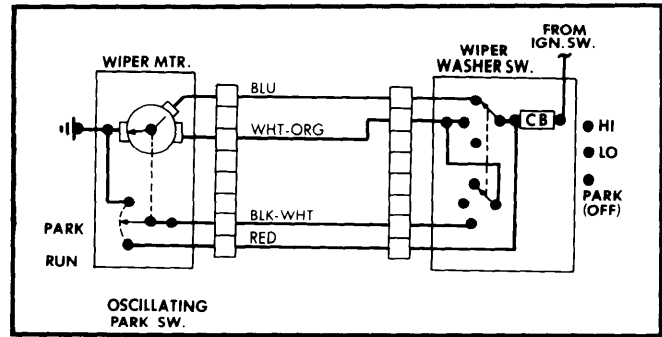

Fig. 2 Wiring Diagram 2-Speed Non-Interval "E" Models

**Bronco and "F" Models** — Disconnect linkage from motor and disconnect electrical plug from motor. Connect green lead from a volt-amp meter to battery positive post and positive (red) lead from meter to low speed connection at plug. Check current draw. Move positive (red) lead from meter to high speed connection at plug and check current draw. Current draw should not exceed 3.0 amperes at either connection. See Fig. 3.

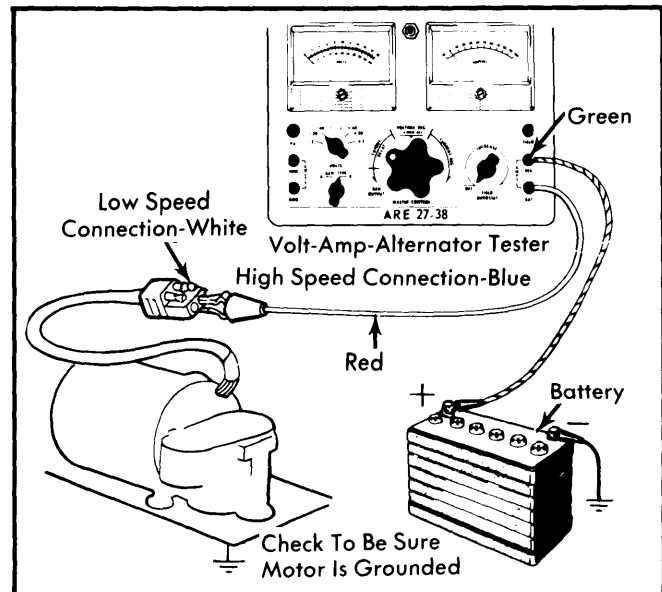

Fig. 3 Motor Current Draw Test Bronco and "F" Models

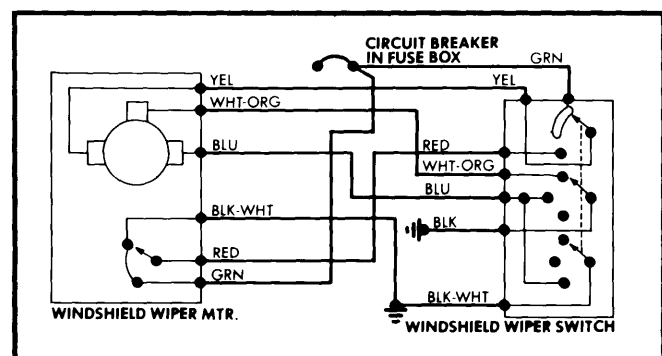

Fig. 4 Wiring Diagram 2-Speed Non-Interval Bronco and "F" Models

# Wiper/Washer Systems

## FORD MOTOR CO. (Cont.)

### CIRCUIT BREAKER

Circuit breaker is located in wiper control switch on all rotary switches and in fuse panel for slide wiper control switches. All pin terminal switches have a rating of 8.25 amperes and all blade terminal switches have a rating of 7.0 amperes. On models with the circuit breaker located in the fuse panel, the rating is 7.5 amperes. The following test does not apply to vehicles with circuit breaker located in the fuse panel. See Fig. 5.

1) Before connecting tester leads as shown in illustration, short tester leads together and adjust current draw until it equals circuit breaker rating. Connect switch to tester and leave switch connected for ten minutes. Current reading should remain at rated current. If circuit breaker opens during the ten minutes, replace wiper switch assembly.

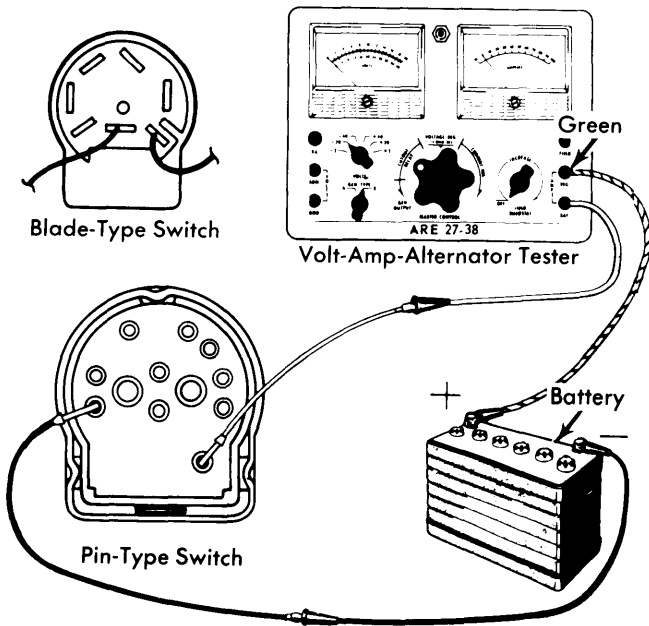

Fig. 5 Circuit Breaker Test

2) Short tester leads together and adjust current draw until it is twice rated current. Connect switch to tester and current reading on ammeter should drop to zero within 30 seconds. If it takes longer than 30 seconds for breaker to open, replace wiper switch assembly.

### WIPER SWITCH CONTINUITY TEST

Check continuity between switch terminals as shown in illustrations. Either a self powered test light or an ohmmeter can be used to test a standard two speed switch. An ohmmeter must be used to test a switch with the intermittent system. To detect marginal operation of switch, rotate knob or slide switch while each reading is being taken. If switch does not exhibit continuity as shown or poor continuity exists, replace switch.

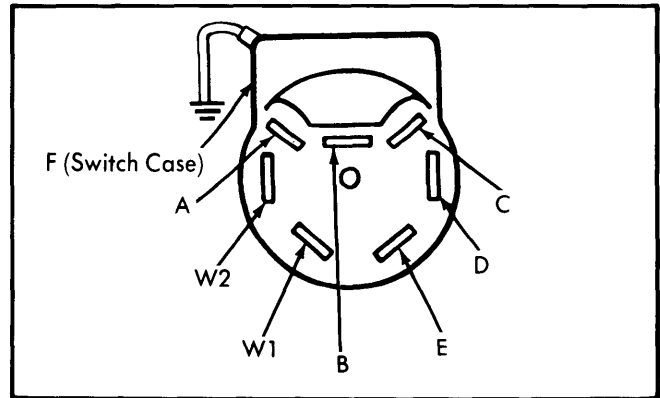

Fig. 6 Blade Type Switch Connector Non-Interval

| Switch Position  | Terminals |
|------------------|-----------|
| Off (Park) ..... | C-D, A-B  |
| Low .....        | A-B-C     |
| High .....       | A-B-E     |
| Wash .....       | W1-W2     |

| Intermittent Switch Position | Intermittent Terminals |
|------------------------------|------------------------|
| Off (Park) .....             | A-B, D-E               |
| Low .....                    | A-B, D-E-F             |
| High .....                   | D-E-F, A-B-C           |
| Intermittent .....           | ⓪D-E-F, A-B, D-E       |
| Wash .....                   | W1-W2                  |

⓪ - Variable resistance between terminals D-E should be minimum 100-900 ohms and maximum 5600-8400 ohms.

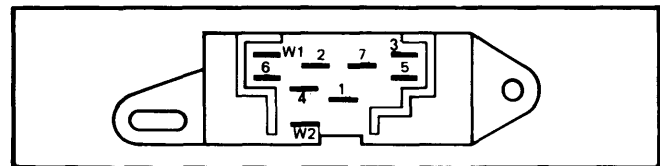

Fig. 7 Blade Type (Slide Switch) Connector Non-Interval

| Switch Position  | Terminals |
|------------------|-----------|
| Off (Park) ..... | 1-5, 3-7  |
| Low .....        | 1-4, 2-7  |
| High .....       | 1-4, 2-6  |
| Wash .....       | W1-W2     |

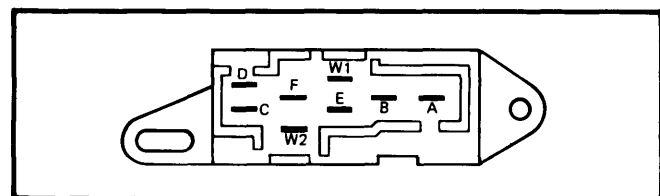

Fig. 8 Blade Type (Slide Switch) Connector Interval

## FORD MOTOR CO. (Cont.)

| Switch Position    | Terminals |
|--------------------|-----------|
| Off (Park) .....   | A-E       |
| Low .....          | B-E-F     |
| High .....         | B-D-F-C   |
| Intermittent ..... | B-E-F-C   |
| Wash .....         | W1-W2     |

**NOTE** — Resistance between terminals F-C will vary  $500 \pm 400$  ohms at minimum dwell to  $10,000 \pm 2000$  at maximum dwell.

### INTERMITTENT GOVERNOR

If intermittent operation is unsatisfactory, check motor current draw, then check control switch and all connecting wires for continuity. If motor, switch and connecting wires are satisfactory, replace electronic governor assembly.

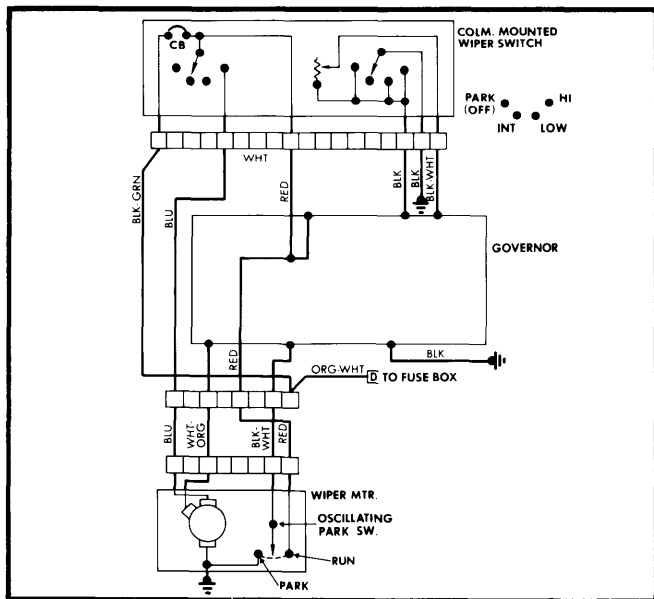

**Fig. 9 Wiring Diagram 2-Speed Interval Bronco and "F" Models**

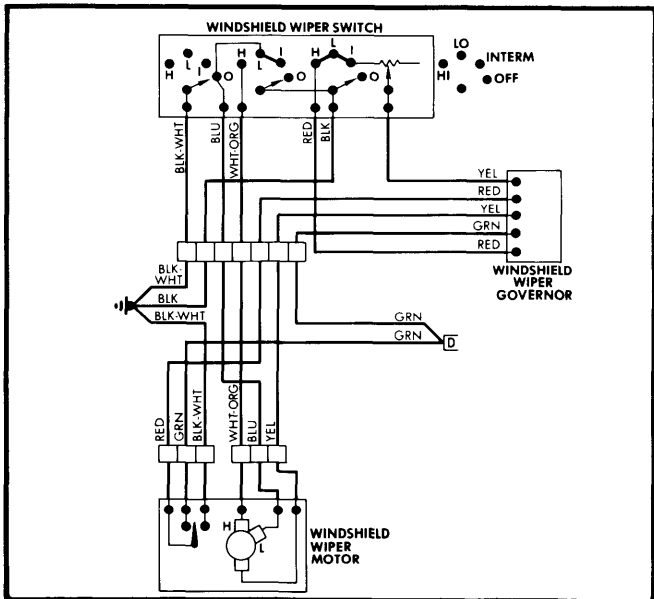

**Fig. 10 Wiring Diagram 2-Speed Interval (Depressed Park) "E" Models**

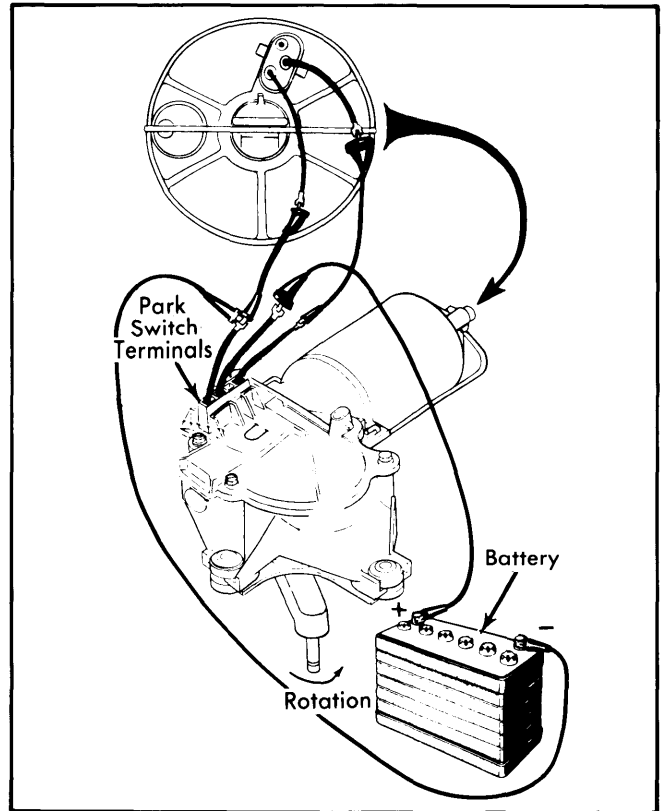

**Fig. 11 Motor Park Test "E" Models**

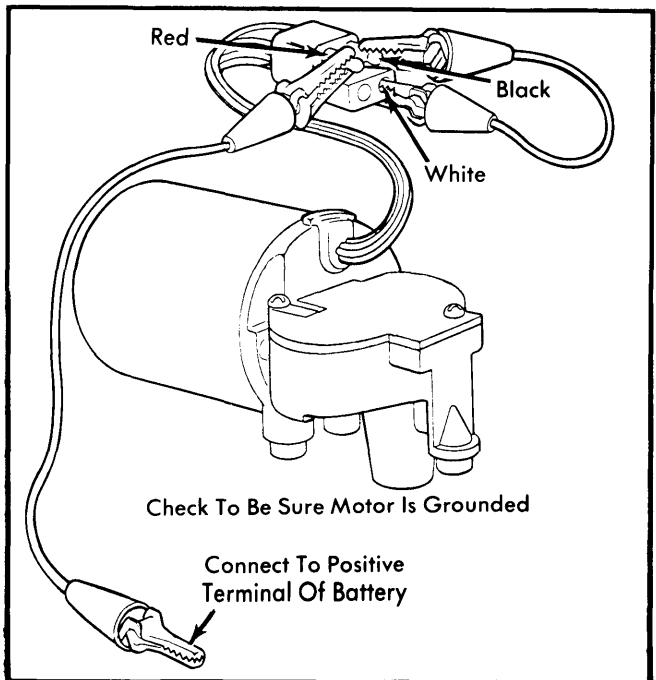

**Fig. 12 Motor Park Test Bronco and "F" Models  
REMOVAL & INSTALLATION**

### WIPER MOTOR

**Bronco** — Motor and bracket assembly is mounted on left side of windshield header. Remove cover and disconnect linkage

## FORD MOTOR CO. (Cont.)

arm and pivot shaft assembly from motor drive arm by removing retaining clip. Disconnect wires at multiple connector and remove bolts attaching mounting bracket to windshield header. Remove motor and bracket assembly from vehicle. To install, reverse removal procedure.

**"F" Models** – Disconnect battery ground cable and remove radio (if equipped). Remove any engine components attached to lower bolt of wiper bracket and remove wiper motor bracket attaching bolts. Disconnect wires, wiper arm linkage from motor shaft and remove motor from vehicle. To install, reverse removal procedures.

**"E" Models** – Disconnect battery ground cable, remove fuse panel and bracket assembly. Then disconnect wires at motor brush cap and gear box cover. Remove wiper arm blade assemblies from pivot shaft, outer air inlet cowl and clip retaining motor drive arm to linkage mounting arm and pivot shaft assembly. Remove motor attaching bolts and remove motor from vehicle. To install, reverse removal procedures while noting the following: If a new motor is installed, motor must be in park position.

### WIPER CONTROL SWITCH

**"E" Models** – Disconnect battery ground cable and remove windshield wiper switch knob. Remove ignition switch bezel. Depress button on top of headlight switch and pull knob and shaft from switch. Remove screws at bottom of finish panel and pry two upper retainers away from instrument panel assembly. Disconnect connector from wiper switch, remove switch attaching bolts and remove switch from vehicle. To install, reverse removal procedures.

**Bronco and "F" Models** – Disconnect battery ground cable and remove wiper switch knob, bezel nut and bezel. Pull switch out from under instrument panel and disconnect plug connector from switch. Remove switch from vehicle. To install, reverse removal procedure.

### INTERMITTENT GOVERNOR

**"E" and "F" Models** – Governor is mounted on lower flange of instrument panel. Disconnect wire connectors from governor, remove attaching screws and remove governor. To install, reverse removal procedure.

### SWITCH ASSEMBLY

**NOTE** – "E" models switch assembly is identified by the letter "U" stamped on outside surface of assembly.

**"E" Models** – To remove cover and switch assembly, remove four cover attaching screws and replace using the appropriate kit, making sure ground strap is reinstalled under cover screw. To remove brush end plate, observe position of bale retainer, then pry off using a screwdriver. Remove end plate and plug, then replace using the appropriate kit while noting the following: Use a fine wire probe through hub opening to position brushes on commutator. Rotate end plate to position key in notch and assemble plug. Do not overbend bale retainer when installing. See Fig. 13.

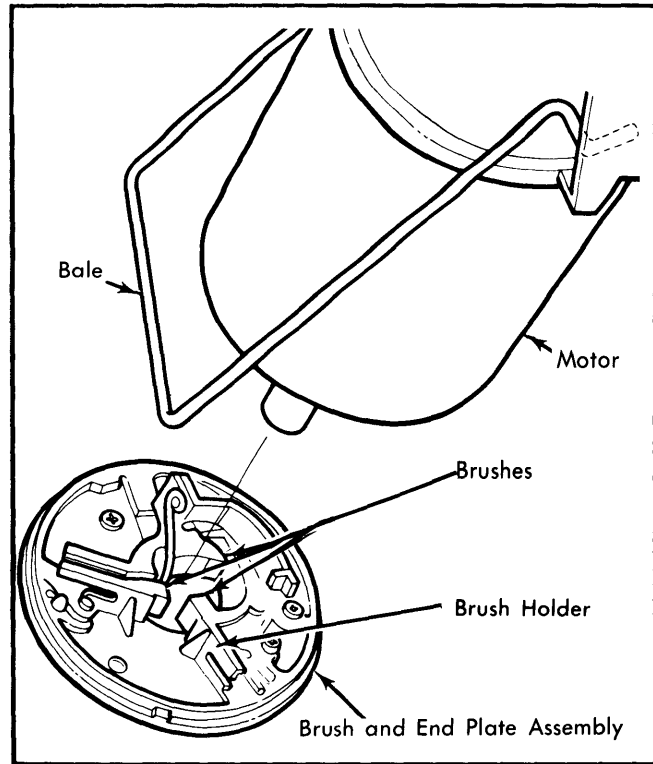

Fig. 13 Motor Brush End Plate Assembly, "E" Models

## OVERHAUL

### WIPER MOTOR

**Disassembly (Bronco and "F" Models)** – 1) Remove ground terminal and gear cover. Remove idler gear by pressing shaft (with retainer) out of motor housing. Remove motor through bolts, case, switch terminal insulator sleeve and armature.

**CAUTION** – Do not pound case magnet assembly as damage may occur to ceramic magnets.

2) Mark position of output arm with respect to output shaft for reassembly. Remove the output arm retaining nut, output arm, wave washer, flat washer, "O" ring, leaf spring, output gear shaft assembly, parking switch lever and plate.

3) Remove brushes, brush springs and wire harness. Remove brush plate and switch assembly, then remove switch contact to parking lever pin from gear housing.

**Reassembly (Bronco and "F" Models)** – 1) Position housing on flat surface with inside of housing facing up. Position parking switch lever and lever plate with cam rider pointing toward gear housing output shaft hole. Apply suitable grease to output gear teeth and shaft bearing surface. Insert shaft in bearing ensuring parking switch lever is clear of cam and gear assembly

2) Install idler gear on shaft and insert shaft through park lever and plate. Using a drift and hammer, lightly tap gear and pinion shaft to proper depth.

**CAUTION** – Do not allow push nut to put a preload on gear. A .001-.007" clearance is necessary.

## FORD MOTOR CO. (Cont.)

3) Position brush springs and brushes in holder, then wrap wire around them to hold brushes in retracted position. Push insulated brush connector into switch terminal. Place switch contact to parking lever pin in gear housing, then position brush plate assembly to housing and install retaining screws.

4) Apply suitable grease to ball bearing in end of armature shaft, position armature shaft in gear housing and remove brush retracting wires. While holding armature in position, install motor case and magnet assembly and through bolts.

**NOTE** — Align indicator marks on case and gear box before installing thru-bolts.

5) Apply suitable grease to worm gear, pinion and idler gear. Install end play spring in housing. Apply grease around end of armature shaft and install gear housing cover.

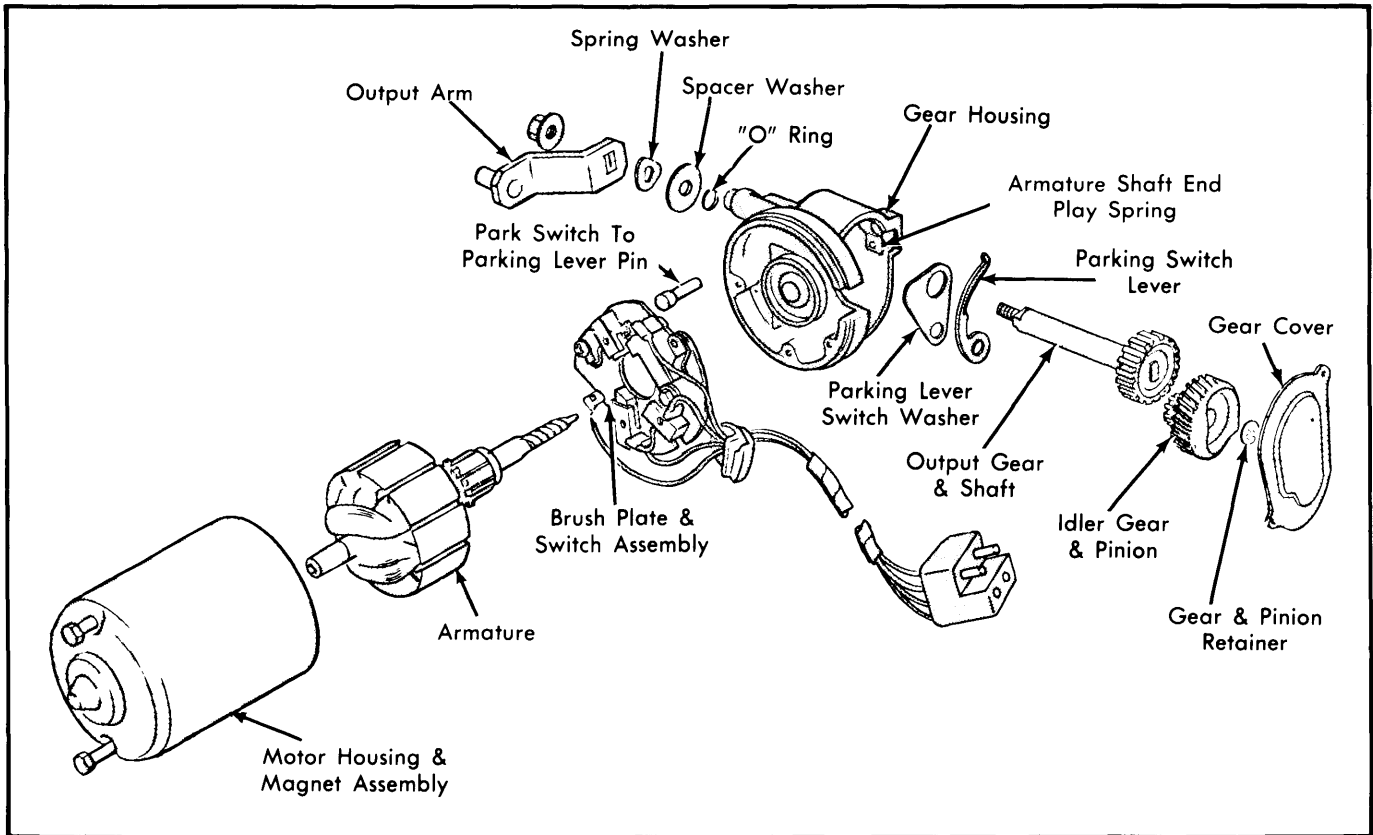

Fig. 14 Exploded View of Wiper Motor Assembly  
Bronco and "F" Models