

## CHRYSLER CORP.

Dodge  
Plymouth

### DESCRIPTION & OPERATION

Fuel, temperature and oil pressure gauges operate on the constant voltage principle through a common voltage limiter which provides intermittent current to the gauge system.

**Fuel Level Gauge** — A hinged float arm in fuel tank raises or lowers depending on fuel level, and contacts a variable resistor in the fuel gauge sending unit. This provides a change of resistance in the fuel gauge circuit. This resistance registers on instrument panel gauge in the form of a level reading.

**Temperature & Oil Pressure** — The operation of temperature and oil pressure indicating systems is identical in operation to the fuel system, with the exception of the method of varying resistance of the sending units.

In temperature, the resistance of the disc in sending unit varies with a direct relation to coolant temperature. When coolant temperatures are high, resistance is low, when coolant temperatures are low, resistance is high.

In oil pressure, the sending unit resistance is controlled by a diaphragm. The diaphragm is actuated as oil pressure increases or decreases.

**Oil Pressure Warning Light** — The oil pressure switch is mounted on the engine (location depends on engine). When oil pressure is high (normal) switch is held in "OFF" or "OPEN" position, allowing no current to flow to the indicator light. When oil pressure is low, switch is in "ON" or "CLOSED" position allowing current to flow to the indicator light.

**Alternator Indicator System** — Alternator gauge is an ammeter which senses the direction and rate of flow of electrical current to or from battery, thereby indicating whether battery is being charged or discharged.

### TESTING

#### VOLTAGE LIMITER

To quickly test voltage limiter in vehicle, connect one lead of a voltmeter or test light to temperature sending unit and other lead to a good ground. Leave sending unit wire attached to sending unit. Turn ignition switch "ON". A fluctuating voltmeter or a flashing light indicates voltage limiter is operating.

#### FUEL GAUGE (WITH TESTER)

1) Disconnect wire at fuel tank unit. Connect one lead of suitable gauge tester (C-3826) to wire terminal, and other lead to a good ground. Turn ignition "ON", turn tester knob to "H" position and observe instrument panel gauge. Gauge should read "FULL", plus two pointer widths minus one pointer width. Turn tester knob to "M", gauge should read  $\frac{1}{2}$  plus or minus two pointer widths. Turn knob to "L" and gauge should read "EMPTY", plus one pointer width, minus two pointer widths.

2) If panel gauge does not perform as prescribed, continuity of circuit from tank sending unit to panel unit should be tested with special attention to printed circuit board before replacing gauge. If panel performs properly when tested but fails to operate properly when connected to vehicle system, fuel tank

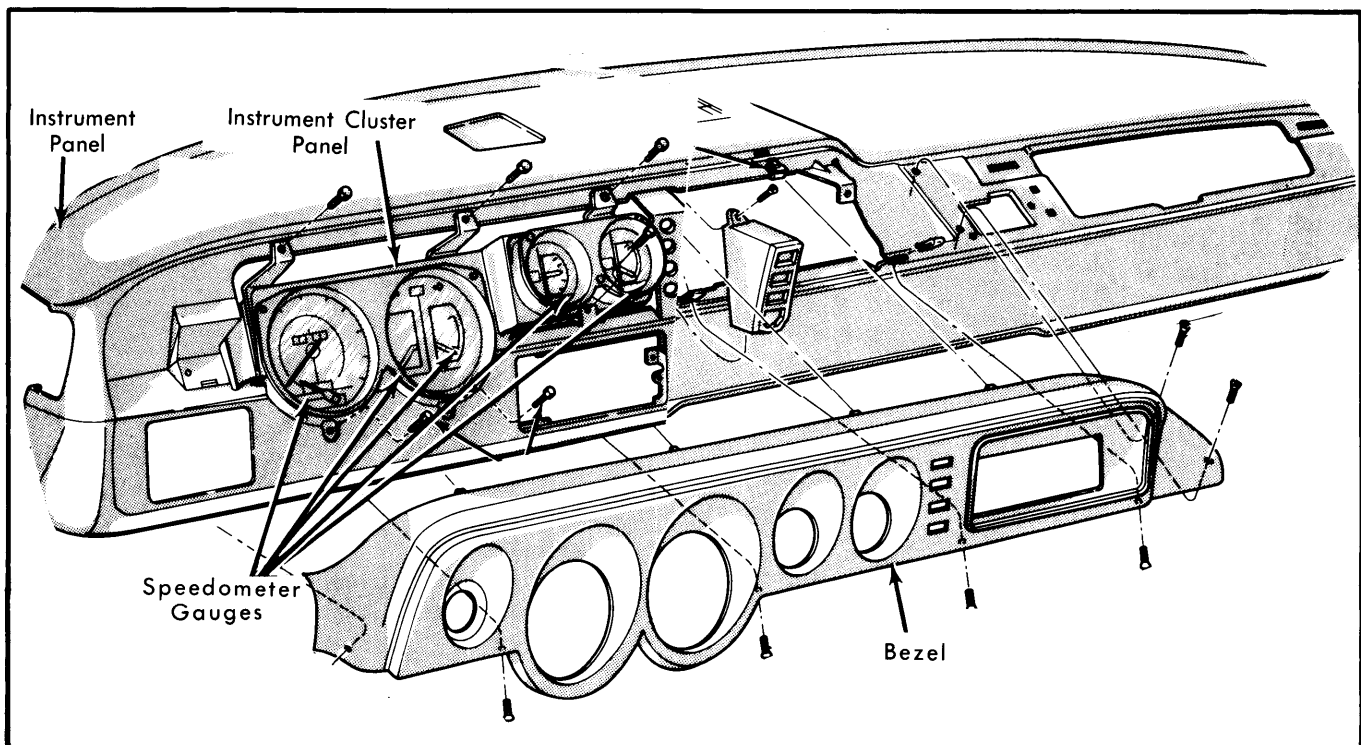

**Fig. 1 Chrysler Corp. Instrument Cluster & Bezel  
(Except Motor Home)**

## CHRYSLER CORP. (Cont.)

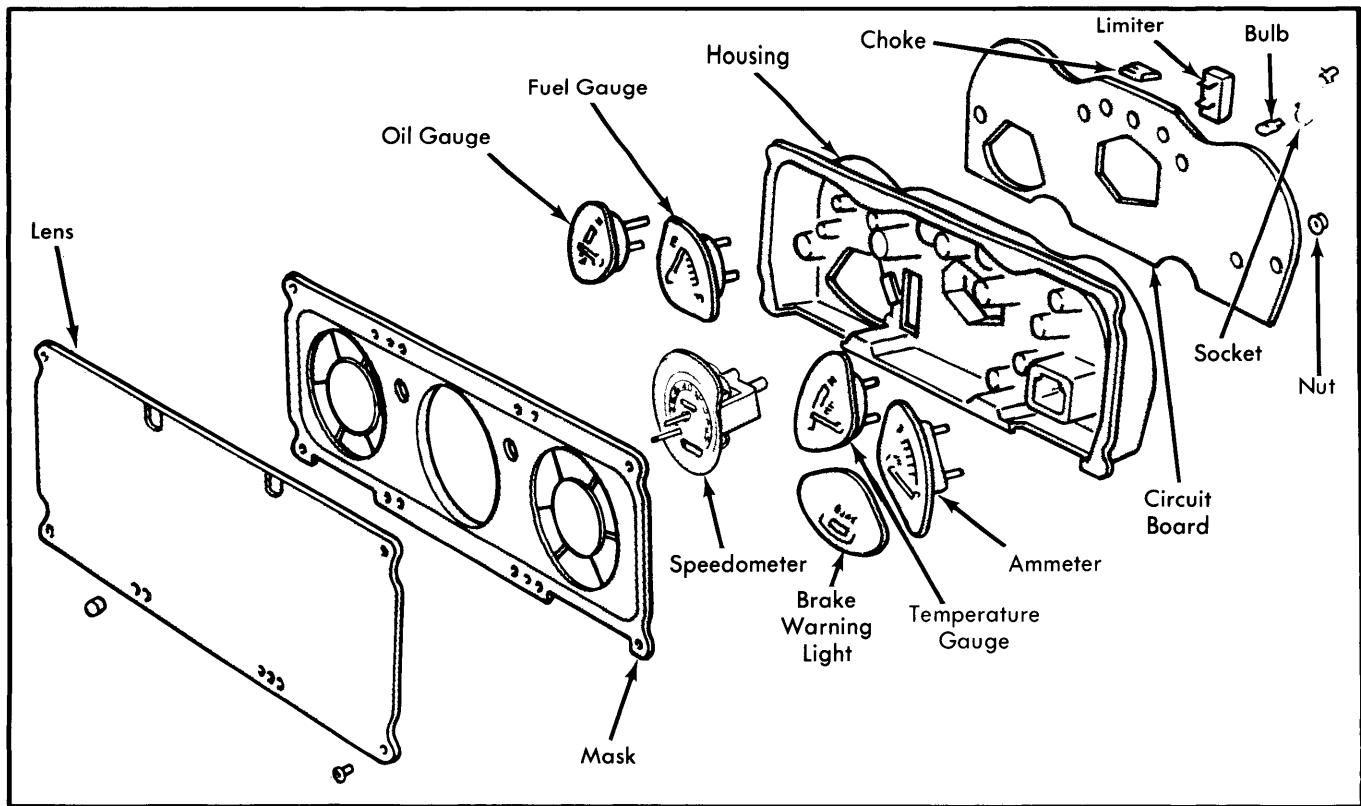

Fig. 2 Exploded View of Chrysler Motor Home Instrument Panel

sending unit ground strap should be inspected for proper installation on fuel line. If ground continuity is good, remove tank unit for testing.

### FUEL GAUGE (WITHOUT TESTER)

1) Disconnect wire from terminal on fuel tank sending unit. Attach wire to known good sending unit. Connect jumper wire between sending unit fuel pick up tube and a good ground. To check fuel gauge, allow at least 2 minutes at each test point for gauge to settle. Clip float arm of sending unit to its empty stop and turn ignition key to "ON" position. Gauge should read "EMPTY" plus one pointer width, minus two pointer widths. Move and clip sending unit float arm to full stop. Gauge should read "FULL" plus two pointer widths, minus one pointer width.

2) If fuel gauge does not perform as indicated, continuity of circuit from tank sending unit to panel should be tested with special attention to printed circuit board. Also check voltage limiter before replacing gauge. If panel gauge performs satisfactorily with Tester C-3826A or known good sending unit, check fuel tank and original fuel gauge sending unit by removing sending unit from tank. Connect sending unit wire and jumper wire as in step 1). If fuel gauge now checks within specifications, original unit is electrically okay.

3) Check ground strap from sending unit to fuel line for continuity, check for deformed sending unit, improper installation, deformed mounting flange on fuel tank, or deformed bottom of fuel tank. Then recheck sending unit.

### FUEL TANK SENDING UNIT

Disconnect wire from terminal on fuel tank sending unit. Connect one lead of tester (C-3826) to disconnected wire and other lead to good ground. Allow at least two minutes at each test point for gauge to settle. Tapping instrument panel will help position pointer. Turn ignition key to "ON" position and turn tester knob to "L" position. Gauge should read "EMPTY", (plus one pointer width or minus two pointer widths). Turn knob to "M" position, gauge should read  $\frac{1}{2}$  "FULL" (plus or minus two pointer widths). Turn knob to "H" position, gauge should read "FULL" (plus two pointer widths or minus one pointer width).

### TEMPERATURE GAUGE

Disconnect terminal from temperature sending unit on engine. Connect one test lead of suitable tester (C-3826) to terminal and other lead to a good ground. Turn ignition "ON", turn tester knob to "L" and temperature gauge should show "C" plus or minus  $\frac{1}{8}$ ". Turn tester knob to "M", pointer should advance to driving range left of  $\frac{1}{2}$  position of dial. Turn tester knob to "H", gauge pointer should move to "H" position on dial. If gauge responds as stated, but does not operate with terminal attached to sending unit, replace sending unit. If gauge does not respond, check for loose connections, broken wire, open printed circuit or faulty gauge.

### AMMETER GAUGE

Turn headlights "ON" (do not start engine). Ammeter needle should move toward the "D" or discharge scale. If no move-

## CHRYSLER CORP. (Cont.)

ment of the needle is observed, check terminals for loose wires. If terminals are secure, ammeter is defective. If needle moves toward the "C" or charge side, the connections are reversed.

### OIL PRESSURE WARNING LIGHT

Check low oil pressure warning light system by turning key to "ON" position and observing pressure light. If light comes on, start engine. If light stays on, immediately turn off engine and use direct pressure gauge to check oil pressure. If pressure is to specifications, check for grounded wire or replace oil pressure sending unit. With ignition key in "ON" position, and light does not come on, disconnect lead of sending unit and touch it to ground. If bulb comes on, replace sending unit. If bulb does not come on, light bulb is burned out or bulb socket, wiring or connections are faulty.

### OIL PRESSURE GAUGE

Disconnect wire from oil pressure sending unit on engine. Connect one lead of a suitable tester (C-3826) to removed wire and other lead to a good ground. Place tester knob in "L" position, and turn ignition "ON". Do not start engine. Oil pressure gauge should read "L" plus or minus  $\frac{1}{8}$ ". Turn tester knob to "M" position, oil pressure gauge should advance to  $\frac{1}{2}$  position on dial. With tester knob in "H" position, gauge should also advance to "H" position. Should gauge respond to the above tests, but fail to operate when connected to vehicle system, indications are of a defective sending unit. Should gauge fail to respond to above tests, check for loose connection, broken wire or a faulty gauge.

### BRAKE WARNING LIGHT

Brake warning system light comes on when ignition switch is "ON" with parking brake applied, when one of the two service brake systems fails or when ignition switch is positioned to "START". Test system by hoisting vehicle with helper inside to depress brake pedal and observe warning light. Light should come on when bleeder port on wheel cylinder is opened. If light fails to operate, inspect for burned out bulb, disconnected socket, broken or disconnected wiring.

## REMOVAL & INSTALLATION

### SPEEDOMETER & GAUGES

Remove instrument panel cluster, lens plastic mounting clips, and lens. Remove mask, and mounting nuts to gauge being serviced. Remove gauge through front of cluster. To install, reverse removal procedure.

### INSTRUMENT CLUSTER

**All Models (Except Motor Homes)** – Disconnect fusible link under hood and remove 7 screws fastening instrument panel hood and bezel assembly. Pull bezel off upper retaining clips and remove 5 cluster screws. Carefully pull cluster out far enough to disconnect speedometer cable, right and left hand

printed circuit board connectors, and ammeter gauge leads. Remove cluster assembly. To install, reverse removal procedure.

**Motor Homes** – Disconnect battery ground cable and remove screws attaching instrument cluster-to-panel. Disconnect speedometer cable and lead wires to instruments. Remove cluster from vehicle. To install, reverse removal procedures.

### PRINTED CIRCUITS

**Motor Homes** – With instrument cluster removed, remove all gauges and light bulb socket assemblies. Remove voltage limiter and choke. Remove spare ignition, ground terminals and lights. Remove auxiliary gas gauge cover if equipped. Remove attaching screws and printed circuit board from vehicle. To install, reverse removal procedures.

**All Other Models** – With instrument cluster removed, remove voltage limiter and radio capacitor. Remove all lamp socket assemblies and gauges except the speedometer. Remove attaching screws and printed circuit board from vehicle. To install, reverse removal procedures.

### HEADLIGHT SWITCH

**All Models (Except Motor Homes)** – Disconnect fusible link found in engine compartment. Remove left air conditioner and air outlet assembly (if equipped). Reach under instrument panel, depress knob and stem release button located on switch housing and at the same time pull knob and stem assembly out of switch housing located on front of instrument panel. Remove spanner nut mounting switch to panel. Lower switch from behind panel and disconnect all electrical leads from switch. Remove switch from vehicle. To install, reverse removal procedures.

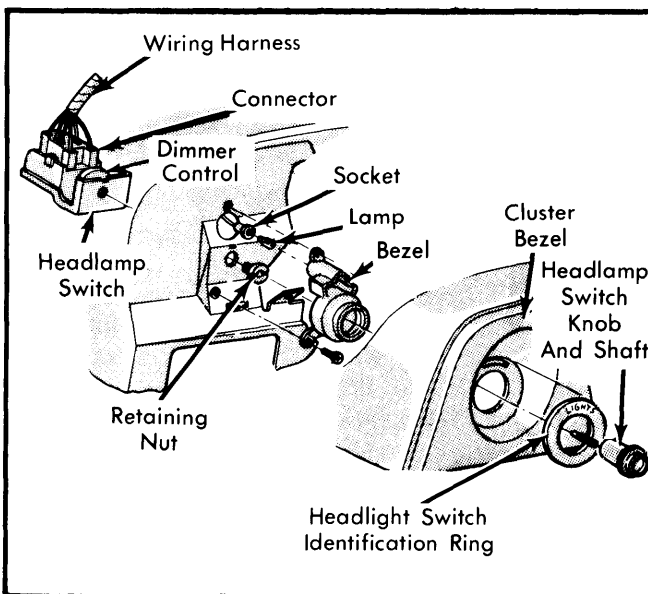

**Fig. 3 Chrysler Corp. Headlight Switch (Except Motor Homes)**