

COMPRESSOR OIL CHECK

GENERAL NOTES

AIR TEMP, TECUMSEH & YORK COMPRESSORS

Oil level on these compressors may be checked with compressor mounted in vehicle. If these compressors are equipped with stem-type service valves, compressor may be "isolated", thereby avoiding necessity of discharging entire system.

NOTE— See *Compressor Isolating* or related paragraphs in this Section.

FRIGIDAIRE COMPRESSORS

When checking oil level on these compressors, it may be necessary to remove compressor from vehicle, as filler plug is located near bottom of compressor. After oil level is checked, system must be evacuated and recharged.

NOTE— See *Frigidaire Compressor* in this Section.

COMPRESSOR ISOLATING

On York and Tecumseh compressors with stem-type service valves (at compressor suction and discharge ports), it will not be necessary to discharge entire system in order to service compressor.

NOTE— See *York & Tecumseh Compressors and Compressor Replacement* in this Section.

REFRIGERATION OIL

Only new, pure, moisture-free refrigeration oil should be used in the air conditioning system. This oil is highly refined and dehydrated (moisture content less than 10 parts per million) to a point well below contamination factor. Refrigeration oil container must be kept tightly closed at all times when not in use, or moisture will be absorbed from the air and introduced into the refrigeration system.

AIR-TEMP COMPRESSOR

CHRYSLER CORP.

Oil capacity is 10-12 oz. in 2-cylinder compressors. 6-cylinder compressors, 9-10 oz. Oil level need not be checked each time system is discharged, unless refrigerant charge has been lost or significant oil loss is indicated. Quantity of oil in compressor sump is measured using dipstick. See Fig. 1.

2-Cylinder (RV-2) Oil Level Check — 1) Slowly discharge system. This will prevent oil from escaping with refrigerant. Near completion of discharge, oil dipstick should be flushed with freon on insure a clean dipstick.

2) Slowly remove compressor filler plug, (some residual pressure will remain after discharge). Insert oil level dipstick until it bottoms in sump. Oil level on stick must be 3-3.4". If necessary, add recommended oil to bring level to specifications. Do not exceed specified amount.

6-Cylinder (C-171) Oil Level Check — 1) Remove compressor and slowly discharge system. This will prevent oil from escaping with refrigerant. With system discharged, disconnect suction and discharge lines from compressor.

2) Drain oil from suction port and discard. Add 9-10 oz. of new refrigerant oil through suction port.

3) Install compressor, connect suction and discharge lines and tighten.

4) Evacuate system and recharge to specification.

Oil Level Check After Discharge — If using fast discharge method (with oil collector can attached to center discharge hose), measure amount of oil in can. Replace this amount with new oil. If following components are replaced, add specified additional amounts of oil:

Evaporator	2 oz.
Condenser	1 oz.
Receiver-Drier	1 oz.

NOTE — After this is completed, use standard dipstick method to determine exact oil level before recharging system.

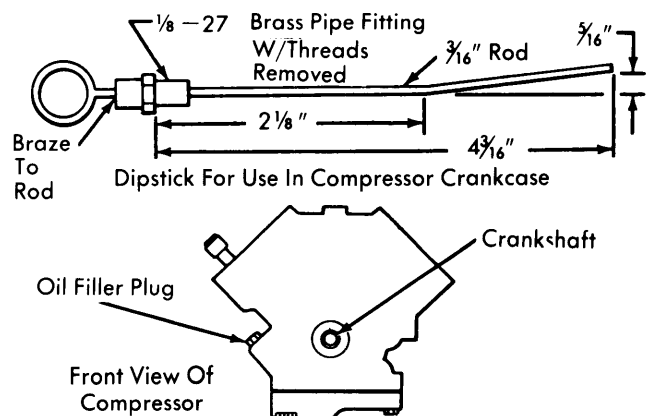

Fig. 1 Air-Temp Compressor Oil Check Point and Dipstick for Chrysler

FRIGIDAIRE COMPRESSOR

GENERAL MOTORS

4 & 6-CYLINDER COMPRESSOR

A/C system with 6-cylinder compressor is fully charged with 10 oz. refrigerant oil. 4-cylinder compressor is fully charged with 6 oz. Optional overhead A/C system is fully charged with 13 oz. Adding additional oil is not required unless a definite oil loss has occurred due to a ruptured line, leaking compressor seal, replacement of system component, compressor overhaul, or collision.

NOTE — Do not reuse old oil; add only new refrigerant oil to system.

On-Car Checking After Minor Repairs — 1) Start engine and allow to idle with A/C on maximum cold. Run engine under these conditions for approximately 10 minutes. Turn off engine and momentarily crack open compressor fill plug allowing a small amount of oil to drain out. Tighten plug then again crack open momentarily. If oil again starts to come out, compressor has the required amount of oil. It is normal for oil to appear foamy.

NOTE — 4-cylinder compressor has no oil sump. It is not necessary to remove compressor to measure oil.

2) Oil can be added without removing compressor by using a special oil injector or by using the A/C service station as recommended by manufacturer. If these are not available, compressor must be removed and correct amount of oil added.

COMPRESSOR OIL CHECK (Cont.)

Off-Car Checking After Major Repair — 1) Before performing repairs, if system is operable, run A/C for several minutes to stabilize system. Turn off air conditioner and engine, discharge system completely, and remove compressor. Slowly remove oil drain plug, then drain and measure oil from compressor, and replace amounts as outlined below. If new compressor is being installed, drain and measure oil from old compressor and add new oil to replacement compressor using described method below; if compressor is being overhauled, add one additional ounce of oil to amount being replaced.

2) If quantity drained is less than 4 ounces, add 6 ounces of replacement oil. If quantity drained is between 4 and 6 ounces, oil is properly distributed throughout the system; add same amount as drained. If quantity drained is more than 6 ounces, add ONLY 6 ounces

NOTE — A-6 system will have 6 oz. of oil in accumulator and/or compressor. This is why BOTH have to be measured.

3) If compressor is inoperable, use the following method: Remove compressor, drain, measure, and discard the oil. If amount drained is more than 1½ ounces, and the system shows no sign of a major leak, add amount drained. If less than 1½ ounces is drained and system appears to have lost excessive oil, add 6 ounces to replacement compressor, or 7 ounces if compressor is being overhauled.

4) When repairing system leaks by replacing components, add additional amounts of oil as specified:

Evaporator	3 oz.
Condenser	1 oz.
Receiver-Drier	1 oz.
Accumulator	1 oz. ①

① — R-4 accumulator holds 2 oz. plus 1 oz. for desiccant

NOTE — If oil drained contains metal chips or other foreign material, replace receiver-drier and flush or replace other components as necessary.

YORK & TECUMSEH COMPRESSORS

FORD MOTOR CO. W/SCHRADER SERVICE VALVES

Check compressor oil level only if any portion of refrigerant system is being replaced, or if system was discharged due to a leak.

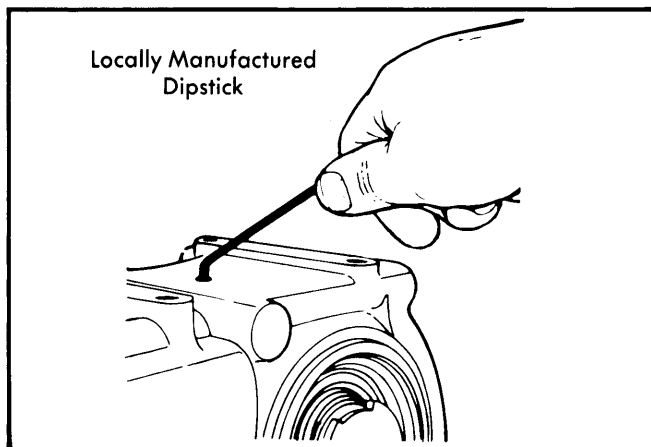

Fig. 2 Checking Compressor Oil Level Horizontally Mounted Unit

On horizontally mounted compressors, oil check hole is located on side of crankshaft which faces up. On opposite or downward side there is a corresponding boss provided on inner wall as an alternate oil check hole, for different mounting. When checking oil level on such a compressor, angle the dipstick such that it bottoms against lower side of compressor and not against boss.

1) After system has been charged, operate for approximately 10 minutes, or until pressures have stabilized (with ambient temperature of 60°F or higher).

2) Stop engine and discharge entire system using a suitable Schrader-Type service valve. Fabricate a suitable dipstick according to specifications (see Fig. 3). Remove oil filler plug and insert dipstick until it bottoms. If necessary, slightly rotate compressor crankshaft by hand so that dipstick will clear. Level on dipstick must be within specifications.

Tecumseh Compressor Oil Level

Application	Measurement
All Models	
Horizontal Mount	7/8-1 5/8"
Vertical Mount	7/8-1 3/8"

FORD MOTOR CO., JEEP & IHC W/STEM TYPE SERVICE VALVES

Oil level should be checked whenever the system is discharged for service part replacement, or if system has self-discharged due to component malfunction. Oil level is checked with compressor in its operating position.

It is important when checking oil level that system has been operated and car interior temperature has cooled to desired setting. This is necessary to stabilize amount of oil in the system.

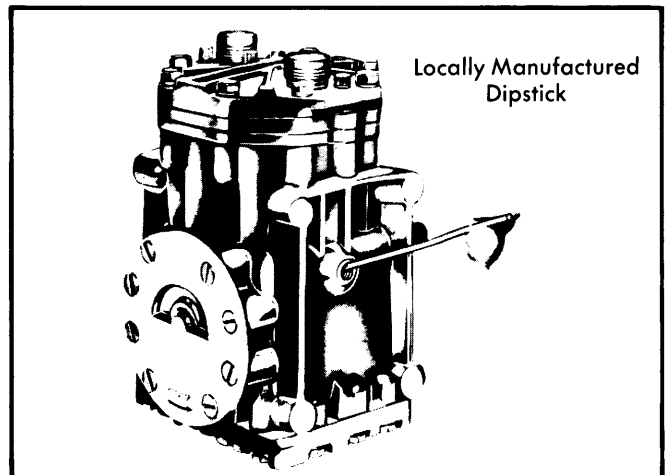

Fig. 3 Checking Oil On Vertically Mounted York Compressor

NOTE — The following oil checking procedure details isolating the compressor prior to checking; however, it is possible to discharge the entire system and then check the oil level.

COMPRESSOR OIL CHECK (Cont.)

York Compressor Oil Level

Application	Measurement
All Models	
Horizontal Mount	1-1 $\frac{3}{8}$ "
Vertical Mount	1-1 $\frac{7}{16}$ "

1) Turn both the high and low pressure service valve clockwise as far as possible (front-seat position). Loosen cap on the high pressure service valve and bleed residual pressure from compressor.

CAUTION — Only loosen cap a small amount and DO NOT remove cap until pressure is totally relieved.

NOTE — Oil level check plugs are located on either side of compressor crankcase; use check plug which is most convenient when checking oil level with compressor on car.

2) Fabricate a suitable dipstick according to specifications. Using proper end of dipstick, check oil level. Add clean refrigerant oil if necessary. Install new "O" ring seal on filler plug.

3) When oil check is complete, compressor must be purged of air before operating the system.

NOTE — See procedure as outlined in Compressor Replacement in COMPONENT REPLACEMENT Section.

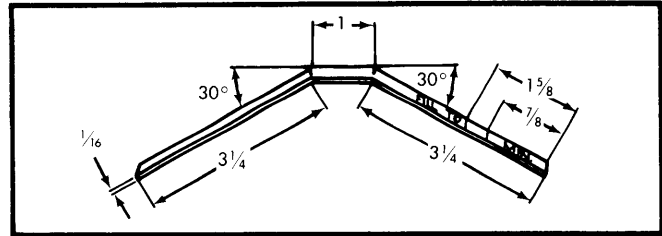

Fig. 4 Dimensions for Locally Made Tecumseh Compressor Oil Level Dipstick

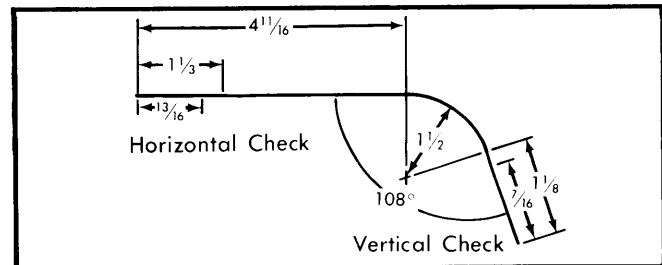

Fig. 5 Dimensions for Locally Made York Compressor Oil Level Dipstick

COMPONENT REPLACEMENT CAUTIONS

BEFORE OPENING THE SYSTEM

Before disconnecting any lines or fittings, the system must be completely discharged; however, if only the compressor is being removed and the compressor is equipped with stem-type service valves (York or Tecumseh), compressor may be isolated without discharging the system.

NOTE — See Compressor Isolation Method.

DISCONNECTING LINES & FITTINGS

After system is discharged, carefully clean entire area around coupling nut to prevent dirt from entering the system. Always use two wrenches to avoid twisting or distorting lines and fittings (hold fitting with one wrench while loosening coupling nut with second wrench). Cap or plug all LINES and FITTINGS immediately to prevent entry of air and moisture into system and do not remove these caps until connections are being made.

See following pages for removal and installation of each component. After replacement or repaired component is installed, connect lines as directed below.

COMPONENT REPLACEMENT

See following pages for removal and installation of each component. After replacement or repaired component installed, connect lines as directed below.

In addition to checking and adjusting the compressor oil level (see Compressor Oil Check), certain component replacement requires additional refrigeration oil. Add specified amounts of oil directly to the component prior to installation.

Application	Amount
With Frigidaire Compressor	
Evaporator	3 oz.
Condenser	1 oz.
Receiver-Drier	1 oz.
A-6 Accumulator	1 oz.
R-4 Accumulator	2 oz.
With Air-Temp Compressor	
Evaporator	2 oz.
Condenser	1 oz.
Receiver-Drier	1 oz.

CONNECTING LINES & FITTINGS

A new "O" ring should be used in all instances when connecting lines and fittings (dip "O" ring in clean refrigeration oil and make certain it is not twisted during installation). Always use two wrenches to avoid twisting or distorting lines and fittings, tighten coupling nuts securely.

PLACING SYSTEM IN OPERATION

After component replacement and/or system servicing has been completed and all connections have been made, proceed as follows:

- 1) Evacuate the system using a vacuum pump.
- 2) Charge the system with new R-12 (refrigerant) according to each individual vehicle manufacturers procedure as outlined in this Manual.

NOTE — Also see Refrigerant Capacity in this Section.

- 3) Leak test the system, with particular attention to all new connections and components.
- 4) Make a performance test of the system.