

Alternators & Regulators

CHRYSLER CORP. ELECTRONIC REGULATOR

Chrysler Corp.

DESCRIPTION

Regulates electrical system voltage by limiting output voltage generated by alternator. This is accomplished by controlling amount of current that is allowed to pass through alternator field winding. Regulator has no moving parts and requires no adjustment after it is set at factory. Unit contains several semiconductor components, transistors and diodes plus some resistors and a capacitor. A large transistor is placed in series with alternator field winding and a control circuit which senses system voltage and turns transistor on and off as required. As alternator speed and electrical system load conditions change, control circuit is turning transistor on and off many times per second most of the time engine is in operation. The only time transistor is not turning on and off rapidly, is during low engine speed operation when high electrical loads are present (which require alternator field to be in the on state continuously). Electronic regulator control circuit can also vary the regulated system voltage up or down as temperature changes.

TESTING

NOTE — Battery specific gravity should be above 1.200 for a proper regulated voltage check. Charge battery or use a good test battery before testing regulator.

NOTE — Where tester (C-4133) is available, use an adapter (C-4341) to switch circuit of regulator to be tested. The adapter has a three position switch to select regulator part number or regulator installed. Follow manufacturers test procedure.

1) Connect positive lead of a voltmeter to terminal of ballast resistor as shown in illustration. DO NOT remove connector from ballast resistor. Connect negative lead of voltmeter to a good ground. Start and run vehicle at 1250 RPM with all lights and accessories turned off. Check voltmeter and note that regulator is working properly if voltage readings are within specifications.

2) If voltage is not within limits or is fluctuating, check that regulator has a good ground. With engine off, disconnect regulator terminals. Turn ignition on, but do not start engine. If battery voltage is present at wiring harness terminal, replace regulator and repeat test.

Specifications

Ambient Temperature ^①	Voltage Range
-20°F	14.9-15.9
80°F	13.9-14.6
140°F	13.3-13.9
Above 140°F	Less than 13.6

① — Ambient temperature is measured ¼" from regulator.

ADJUSTMENT

The Electronic Voltage Regulator cannot be adjusted. If specifications are not obtained and investigation has shown the rest of electrical system to be satisfactory, then regulator must be replaced.

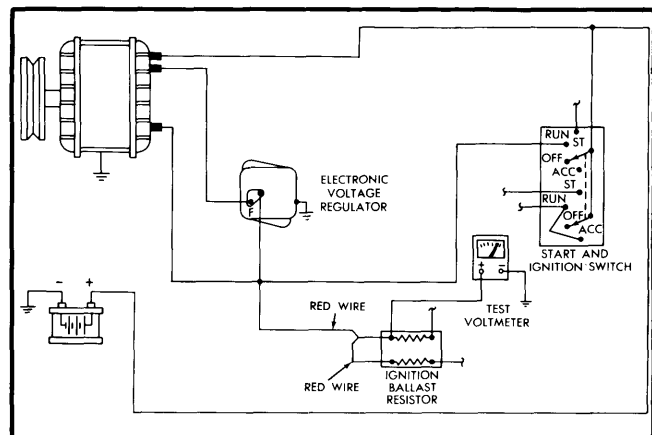

Fig. 1 Test Connections for Voltage Regulator Test