

CHRYSLER CORP. ALTERNATORS

Chrysler Corp.

DESCRIPTION

Alternator main components are the rotor, stator, rectifiers, end shield and pulley. The built-in silicon rectifiers convert A.C. current into D.C. output current. The 100 amp. model has 12 silicon rectifiers; all other models have 6 silicon rectifiers.

IDENTIFICATION

Chrysler Corp. Part No.	Tag Color	Rated Amp. Output
4091563	Violet	41
4091795	Violet	41
3755413	Yellow	60
3874698	Yellow	60
3874729	Yellow	60
3874777	Yellow	60
3895641	Yellow	60
4091565	Yellow	60
4091568	Yellow	60
4091572	Yellow	60
4091727	Yellow	60
4091460	Yellow	100
4091461	Yellow	100

NOTE — Some Chrysler Corp. factory literature may refer to the 100 amp. alternator as a "117 amp." alternator. All specifications and procedures applying to 100 amp. alternator also apply to alternator designated as "117 amp."

SPECIFICATIONS

Rated Amp. Output	① Minimum Amp. Output
41	40@15 Volts
60	57@15 Volts
100	72@13 Volts

① — At 900 engine RPM (100 Amp. Alt.); 1250 RPM all others. Measured at alternator.

Rotation — Clockwise at drive end.

Field Coil Draw — 4.75-6.0 amps. (100 amp.); 4.5-6.5 amps. (all others); at 12 volts while turning rotor manually.

Capacitor Capacity — .50 mfd. ± 20%.

ON VEHICLE TESTS

CHARGING CIRCUIT RESISTANCE

NOTE — Before making test connections, disconnect battery ground cable at battery negative post to avoid accidental shorting of charging or field circuits.

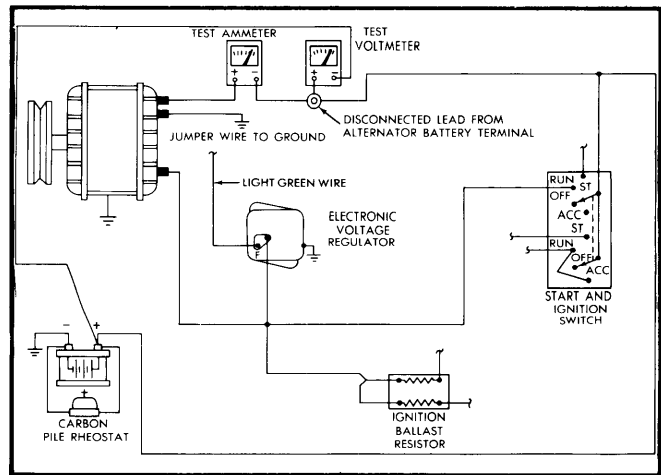

Fig. 1 Diagram Showing Meter Connections for Charging Circuit Resistance Test

1) Disconnect "BAT" lead at alternator and connect a 0-100 ampere scale D.C. ammeter in series between alternator "BAT" terminal and disconnected "BAT" lead. Connect positive lead of D.C. voltmeter to disconnected "BAT" lead and connect negative voltmeter lead to battery positive terminal. Disconnect field lead from alternator, then connect a jumper lead from alternator field terminal to ground. Connect a tachometer, then connect battery ground cable. Connect a variable carbon pile to battery terminals.

2) Start engine and immediately reduce engine speed to idle. Adjust engine speed and carbon pile to obtain 20 amps. flowing in circuit. Voltmeter reading should not exceed 0.7 volts. If a higher voltage drop is indicated, inspect, clean and tighten all connections in charging circuit.

NOTE — If necessary, test voltage drop at each connection to locate connection with excessive resistance.

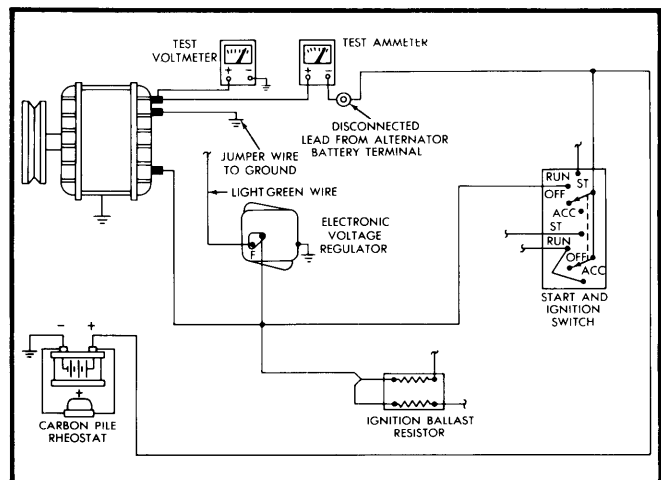

Fig. 2 Diagram Showing Meter Connections for Alternator Current Output Test

CHRYSLER CORP. ALTERNATORS (Cont.)

CURRENT OUTPUT

1) With test connections made as for "Charging Circuit Resistance", move negative lead of voltmeter to a good ground, then move the positive lead of voltmeter to "BAT" terminal of alternator. Start engine and operate at idle. **CAUTION** — To avoid damage, reduce engine speed to idle immediately after starting.

2) Adjust engine speed and carbon pile until a speed of 900 RPM (100 amp.) or 1250 RPM (all others) and a voltmeter reading of 13 volts (100 amp.) or 15 volts (all others) is obtained. **CAUTION** — Increases in engine speed should not be large enough to allow voltage to exceed 16 volts. Observe ammeter, current output should be within specifications. If output is less than specified, remove the alternator from the vehicle and bench test it.

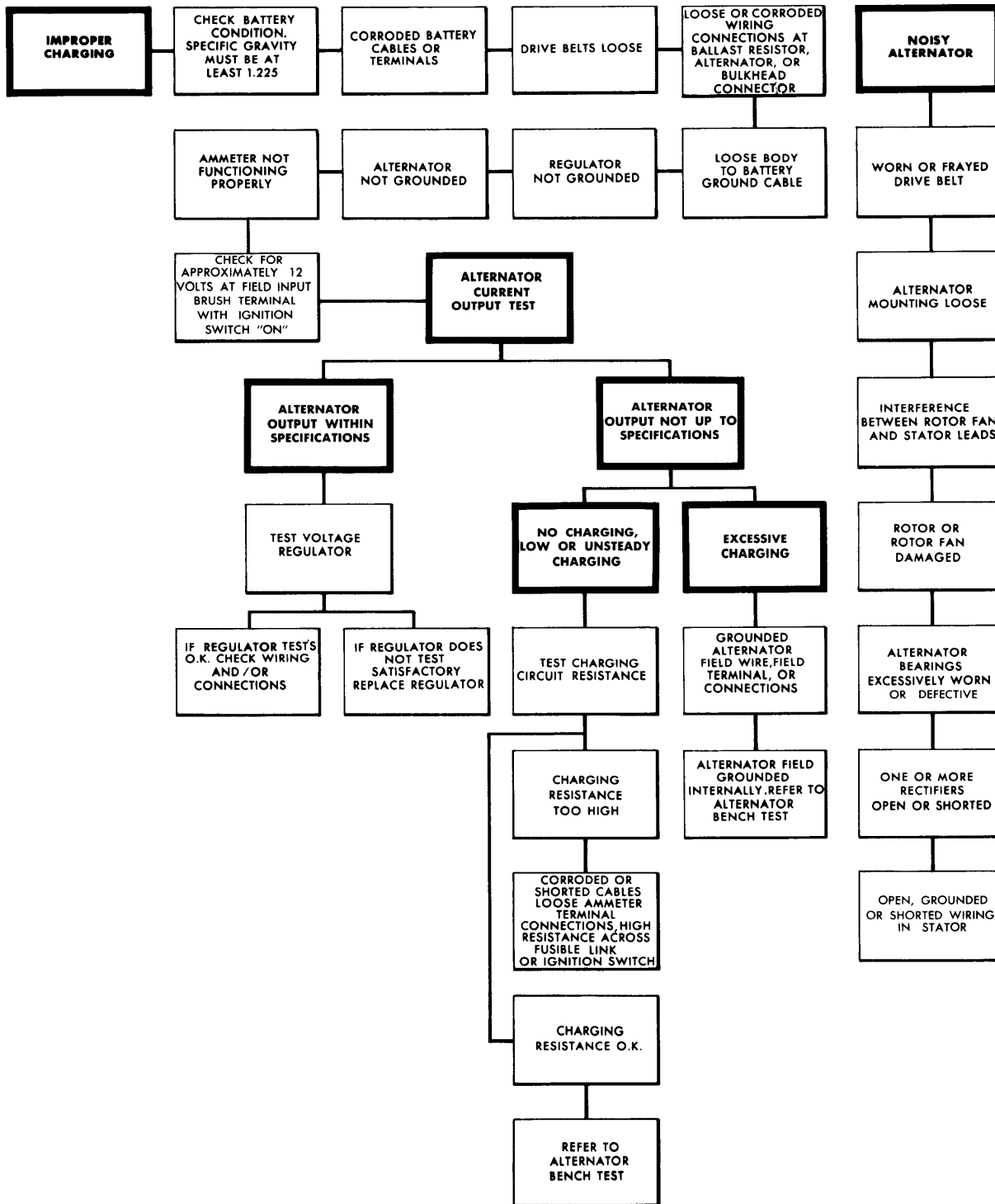

Fig. 3 Charging Circuit Service Diagnosis Guide for All Chrysler Corp. Models

CHRYSLER CORP. ALTERNATORS (Cont.)

BENCH TESTING

FIELD COIL DRAW

Connect a wire between one field terminal of alternator and positive terminal of a fully charged battery. Connect test ammeter positive lead to the other field terminal of alternator and negative lead to battery negative terminal. Slowly rotate alternator rotor by hand. Observe ammeter reading. Field coil draw should be 4.75-6.0 amps. (100 amp.) or 4.5-6.5 amps. (all others) at 12 volts. A low coil draw is an indication of high resistance in field coil circuit (brushes, slip ring, or rotor). A higher coil draw indicates possible shorted rotor coil or grounded rotor. No reading indicates an open rotor or defective brushes.

RECTIFIER (DIODE) TESTS

NOTE — Do not break plastic cases of diodes, cases are for protection against corrosion. Always touch test probe to metal strap nearest diode. Rectifier diodes may be tested with a test lamp or with tester C-3829 as follows:

Test Lamp Method — With rectifier end shield and stator assembly separated, test rectifiers with a 12V battery and suitable test lamp. Connect test lamp to battery and measure rectifier continuity with probes of test lamp touching heat sink and rectifier top strap. Now reverse probes, if lamp lights with current flow in only one direction, rectifier is satisfactory. If lamp lights with probes either way, rectifier is shorted. If lamp does not light at all, rectifier is open. Test each rectifier and both assemblies in this manner.

Tool C-3829 Method — Remove alternator brushes and through bolts. Separate rectifier end housing and stator from drive end housing and rotor. Test rectifiers as follows:

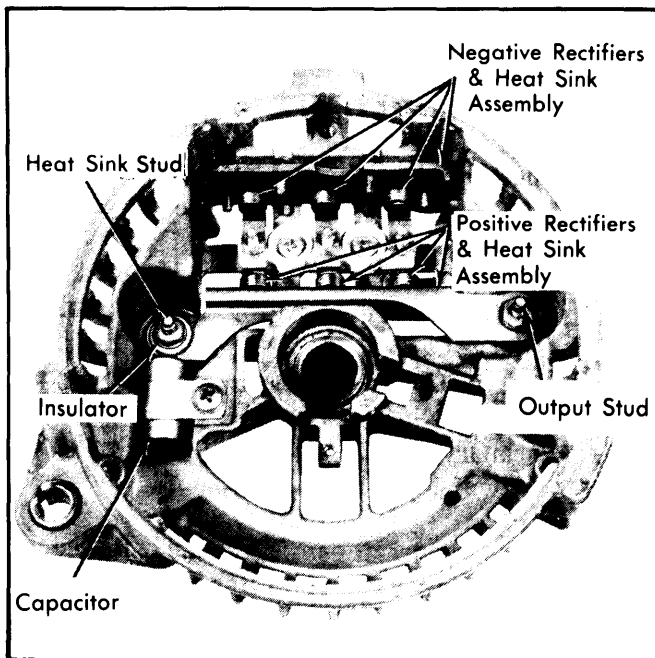

Fig. 4 View Rectifier End Shield

Positive Rectifiers — With alternator on an insulated surface, connect test lead clip to alternator "BAT" output terminal and plug tool into 110 volt A.C. power supply. Touch exposed bare metal connections of each positive case rectifier with test probe. Reading for satisfactory rectifiers will be $1\frac{3}{4}$ amperes or more and should be approximately the same for each rectifier. When two rectifiers are good and one is shorted, reading taken at good rectifiers will be low and reading at shorted rectifier will be zero. Disconnect lead to rectifier reading zero and retest. Reading of good rectifiers will now be within satisfactory range. When one rectifier is open it will read approximately 1 ampere, and two good rectifiers will read within satisfactory range.

Negative Rectifiers — Connect test lead clip to rectifier end housing. Touch exposed connection of each negative rectifier with test probe. Test specifications and results will be approximately the same as for positive case rectifiers, except meter will read on opposite side of scale.

STATOR TEST

NOTE — On 100 amp. alternators, stator windings are "Delta" wound and cannot be checked with common shop equipment for opens and shorts. If stator is not grounded and all other components check correctly, suspect an open or a short in stator.

Separate stator from both end shields. Press test probe firmly onto any pin on stator frame. Be sure varnish has been removed so the pin is bare. Press test probe firmly to each of the three phase lead terminals one at a time. If lamp lights stator lead is grounded. Now press test probe firmly on one phase control lead and contact each of the other two stator leads. Test lamp should light when prod contacts each of the terminals. If lamp does not light, stator is open. Install a new stator if it is open or grounded.

ROTOR TEST

Test rotor for grounded, open or shorted field coils using an ohmmeter. Test for grounds between slip rings and rotor shaft; no continuity should exist. Check for an open field by connecting ohmmeter across slip rings, 1.7-2.1 ohms (100 amp.) or 1.5-2.0 ohms (all others) is normal resistance with rotor at room temperature. Readings above 3.5 ohms indicate high resistance and rotor replacement may be necessary. If reading is below 1.7 ohms (100 amp.) or 1.5 ohms (all others), the field coil is shorted.

OVERHAUL

DISASSEMBLY

1) Remove brush screws, insulating washers, and lift brush assemblies from end shield.

CAUTION — Stator is laminated. Do not burr stator or end shield.

CHRYSLER CORP. ALTERNATORS (Cont.)

2) Remove thru bolts and pry between stator and drive end shield with blade of screwdriver. Carefully separate drive end shield, pulley and rotor assembly away from stator and rectifier end shield assembly.

NOTE — If negative heat sink diode straps are on top of positive heat sink straps, loosen 4 hex-head screws on negative rectifier and heat sink assembly and remove heat sink assembly. Proceed to step 3).

3) Remove nut, washer, and insulator from output (BAT) terminal on outside of end shield. Turn end shield over and remove capacitor, insulated washer, and positive heat sink assembly. Remove insulator from "BAT" terminal hole.

4) Remove mica insulator from end shield and loosen four hex-head screws on negative rectifier and heat sink assembly. Remove two outer screws and remove heat sink assembly.

5) Using suitable puller, remove drive pulley from shaft. Remove screws attaching bearing retainer to drive end shield (100 amp. only). Separate bearing retainer from end shield. Support end shield and tap rotor shaft with a plastic hammer to separate rotor from end shield.

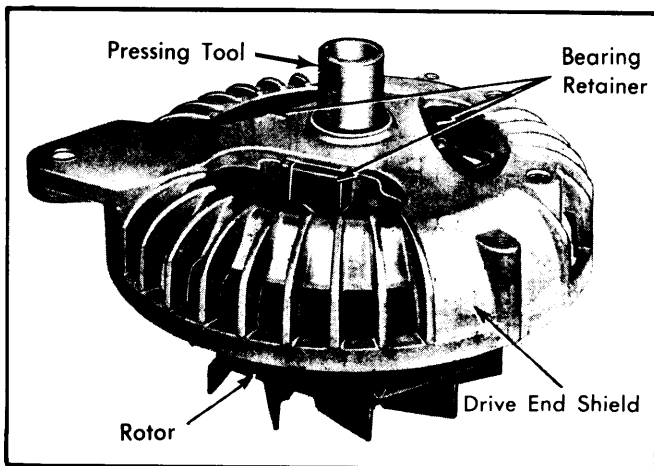

Fig. 5 Installing Drive End Shield Bearing

6) Using a suitable puller, remove drive end ball bearing. If needle roller bearing in rectifier end shield must be removed, it can be pressed out of a properly supported end shield.

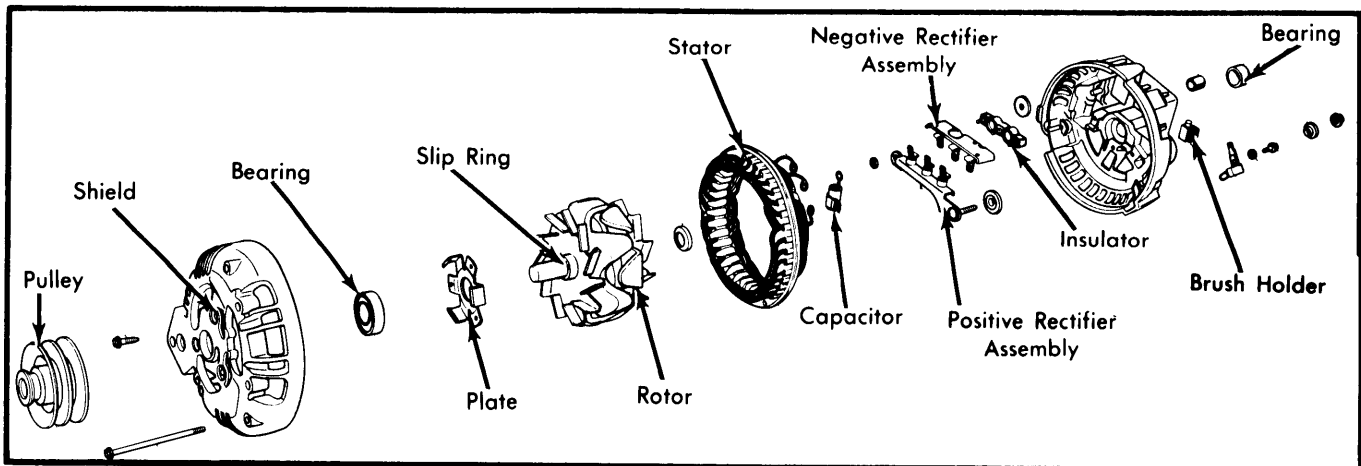

Fig. 6 Exploded View of Typical Chrysler Corp. Alternator

SLIP RING REPLACEMENT

Slip rings are not serviced as a separate item. They are serviced as a rotor assembly.

REASSEMBLY

1) Place grease retainer on rotor shaft and press retainer onto shaft until suitable tool (C-4331, 100 amp.) or (C-3921, all others) bottoms on shaft. Position rectifier end shield bearing on top of bearing. With top part of suitable tool (C-4330-3, 100 amp.) or (C-4201, all others) placed on end shield, press into place until it bottoms.

2) Insert drive end bearing in drive end shield and install bearing retainer plate to hold bearing in place. Position bearing and drive end shield on rotor shaft, and while supporting base of rotor shaft press bearing end shield into position on rotor shaft with an arbor press and suitable adapter (C-3858).

CAUTION — Make sure bearing is installed squarely.

3) Install pulley on rotor shaft. Shaft of rotor must be supported so all pressing force is on pulley hub and rotor shaft, and not on bearings. Do not hammer pulley on.

4) If removed, install output terminal stud and insulator thru end shield. Be sure mica insulators are in place and undamaged. Install positive heat sink assembly over studs; guide rectifier straps over studs on terminal block. Install capacitor. Slide negative rectifier and heat sink assembly into place, position straps and install screws.

5) Position stator over rectifier end shield and install winding terminals on terminal block and press stator pins into each end shield. Route leads so they cannot contact rotor or sharp edges of negative heat sink. Position rotor and drive end shield over stator and rectifier end shield and install thru bolts. Compress both ends manually and tighten through bolts evenly to 40-60 INCH lbs.

6) Install field brushes in insulated holders. Position vertical and horizontal field brushes in proper location in rectifier end shield. Place an insulating washer on each field brush terminal and install lockwashers. Be sure that brushes are not grounded. Rotate pulley slowly by hand to be sure rotor fan blades do not hit stator winding leads.