

## FORD MOTOR CO.

Ford Motor Co.  
"E" Models  
"F" Models

### DESCRIPTION

Speed control system consists of an "ON-OFF" switch, "SET-ACC" and "COAST" switches, servo assembly, speed control sensor, amplifier, wire harness and vacuum hoses to connect components, check valve assembly, and vacuum reserve tank. The switches are located in steering wheel spokes. The amplifier is located under instrument panel and servo assembly is attached to engine intake manifold. Speed sensor is located on left side of dash panel on "E" models and on left fender apron on "F" models. The vacuum reservoir is attached to the left fender apron.

### OPERATION

This system is operational at speeds over 30 MPH. When "ON-OFF" switch is actuated to "ON" position and driver depresses and releases "SET-ACC" button, vehicle speed will be maintained until a new speed is set by driver, brake pedal is depressed, or system turned off. To decrease set speed, apply brake and reset speed using the preceding method or depress the "COAST" switch. When vehicle has slowed to desired speed, release switch and new speed is set into system. To increase set speed, accelerate until desired speed is reached, then depress and release the "SET-ACC" button. Speed may also be increased by depressing "SET-ACC" button and holding in that position while vehicle automatically increases in speed. When desired speed is reached, release button and new speed will be set into system.

### TESTING

#### CONTROL SWITCH

1) Disconnect six-way connector at amplifier. Check battery voltage at light blue/black hash wire when "ON" switch is depressed. Battery voltage should be available from light blue/black hash wire leading from control switches.

2) Connect an ohmmeter between light blue/black hash wire and ground. Check wire for continuity to ground with "OFF" switch depressed. If resistance higher than 1 ohm is found, the wiring, slip rings or switch is at fault, or steering column may not be properly grounded. To check steering column ground, connect an ohmmeter between a good body ground and steering column upper flange. Resistance should be less than  $\frac{1}{2}$  ohm. Rotate steering wheel and check flexible coupling resistance. If resistance higher than 3 ohms is noted, clean horn brush contacts and ground brush. A resistance less than 1 ohm must be obtained before performing the remaining tests.

3) With ohmmeter connected between light blue/black hash wire and ground, depress "SET-ACC" button. A reading of approximately 680 ohms should be indicated on ohmmeter. Depress "COAST" button and a reading of approximately 120 ohms should be indicated on ohmmeter.

#### SPEED SENSOR

Disconnect sensor wires from amplifier and connect an ohmmeter between wire connector terminals (dark green/white stripe and black) at speed sensor end. A reading

of about 40 ohms should be obtained. A reading of 0 ohms indicates a shorted coil and a maximum reading indicates an open coil. Replace sensor in either case. If reading is 40 ohms and speedometer operates properly, speed sensor is probably good. A new sensor can be substituted in place of old sensor to check for proper operation.

#### SERVO ASSEMBLY

1) Disconnect ball chain from throttle linkage. Separate eight-way connector at amplifier, then connect an ohmmeter between the orange/yellow hash wire and gray/black hash wire at the connector. A resistance of approximately 85 ohms should be obtained. Connect ohmmeter between the orange/yellow hash wire and white/pink hash wire at connector. A resistance of approximately 85 ohms should be obtained. Reconnect the ball chain to carburetor.

2) Start the engine with the servo-to-amplifier connector disconnected. Connect orange/yellow hash wire of servo to battery positive terminal, connect white/pink hash wire to ground, and then momentarily touch gray/black hash wire of servo to ground. Servo throttle actuator should tighten bead chain and open throttle. Throttle should hold in that position or slowly release tension on chain.

3) When white/pink hash wire is removed from ground, servo should release bead chain tension immediately. If servo fails any of the preceding tests, replacement of the servo is necessary. If orange/yellow hash wire is shorted to either white/pink hash wire or gray/black hash wire, it may be necessary to replace amplifier.

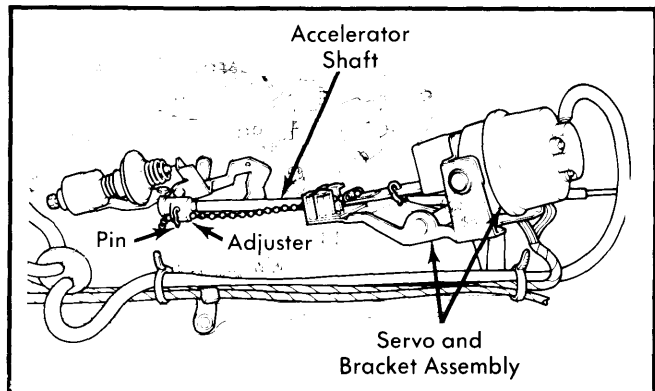

Fig. 1 Engine Compartment Servo and Bracket Installation for "E" Models ("F" Models are Similar)

#### AMPLIFIER

**CAUTION** — DO NOT use a test light to perform amplifier tests as excessive current draw will damage electronic components. Use only a voltmeter of 5000 ohm/volt rating or higher.

**"On" Circuit Test** — Turn ignition "ON" and connect a voltmeter to light blue/black hash wire at amplifier six-way connector. Voltmeter should read 12 volts when "ON" switch in steering wheel is depressed and held. If no voltage is available, conduct Horn Relay Circuit Test and Control Switch Test. Release the "ON" button. A 12 volt reading should remain on voltmeter indicating the "ON" circuit is engaged. If voltage does not remain, check for ground at amplifier, fuse and/or circuit breaker. Insert a known good amplifier and recheck "ON" circuit if necessary.

## FORD MOTOR CO. (Cont.)

**"OFF" Circuit Test** — With ignition "ON" and voltmeter connected to light blue-black hash wire at amplifier six-way connector, depress the "OFF" switch on steering wheel. Voltage should drop to zero indicating "ON" circuit is de-energized. If voltage does not drop to zero, perform Control Switch Test. If switches test good, install a known good amplifier and retest.

**"SET-ACC" Circuit Test** — With ignition "ON" and voltmeter connected to light blue/black hash wire at amplifier six-way connector, depress the "ON" switch, then hold "SET-ACC" button on steering wheel. Voltmeter should indicate approximately 10 volts. Rotate steering wheel and watch voltmeter for variation. If voltage varies more than .5 volt, perform Control Switch Test.

**"COAST" Circuit Test** — With ignition "ON" and voltmeter connected to light blue-black hash wire at amplifier six-way connector, depress the "ON" switch and hold "COAST" button down on steering wheel. Voltmeter should indicate about 6 volts. If all functions check good, perform Servo Assembly Test and Speed Sensor Test. Insert a known good amplifier and recheck system if necessary. **CAUTION** — DO NOT substitute a new amplifier until actuator coils have been tested. See Servo Assembly Test.

### BRAKE STOP LIGHT SWITCH & CIRCUIT TEST

**NOTE** — This test should be performed when brake application will not disengage speed control.

Check for stop light operation with a maximum brake pedal effort of 6 lbs. Check brake pedal actuation and stop light switch if pedal effort required is in excess of specification. If stop lights operate correctly, check battery voltage at black/green stripe wire at six-way connector. Depress pedal

until stop lights are lit and check voltage at red/black stripe wire at six-way connector. If voltage readings differ by more than 1.5 volts, high resistance exists in stop light circuit and must be corrected. If stop lights do not work, the stop light switch, supply circuit and bulbs must be checked for correct operation.

### HORN RELAY CIRCUIT

1) Locate horn relay wire connectors marked "X" and "Y" on wiring diagram illustration. Use a voltmeter to measure for battery voltage on the male side of connector "X" at blue/yellow wire. Use a voltmeter to check for battery voltage on the female side of connector "Y" at blue/yellow wire. With voltmeter still connected to "Y" connector female lead, depress horn switch and voltmeter should read zero.

2) If preceding checks are satisfactory, connect voltmeter to yellow/green wire at horn relay and ground. Depress horn switch and voltmeter should read 12 volts and horn should operate. If horn does not operate, check circuitry between relay and horn.

## ADJUSTMENT

### LINKAGE ADJUSTMENT

Adjust bead chain to obtain .06-.25" actuator arm free travel when engine is at hot idle. Adjustment should be made to eliminate as much slack as possible without restricting carburetor lever from returning to idle. Cut off chain in excess of four beads. On vehicles equipped with solenoid anti-diesel valve, perform this adjustment with ignition switch in "ON" position.

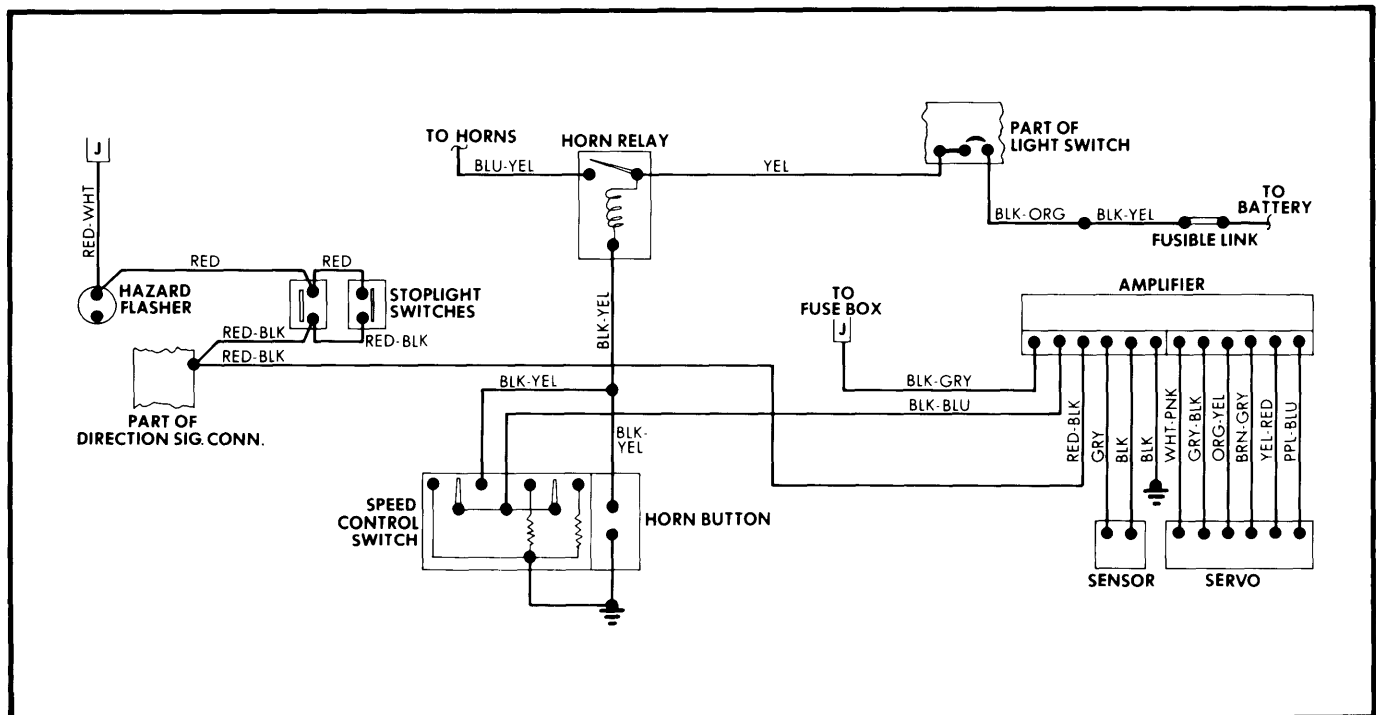

Fig. 2 Wiring Diagram of Ford Motor Co. Automatic Speed Control System