

MOTORCRAFT POSITIVE ENGAGEMENT

Ford Motor Co.
Jeep

DESCRIPTION

Unit is a four pole, four brush starter with three series coils and one shunt coil. The shunt coil is wound around a moveable pole piece which operates the integral positive engagement drive mechanism.

TESTING

STARTER CRANKING CIRCUIT TESTS

Before performing tests, remove and ground coil secondary wire (disconnect at distributor). Place transmission in neutral or park and apply parking brake. Be sure battery is fully charged. When making voltmeter connections, be sure to connect leads to battery posts or threaded terminals and not just to cable ends.

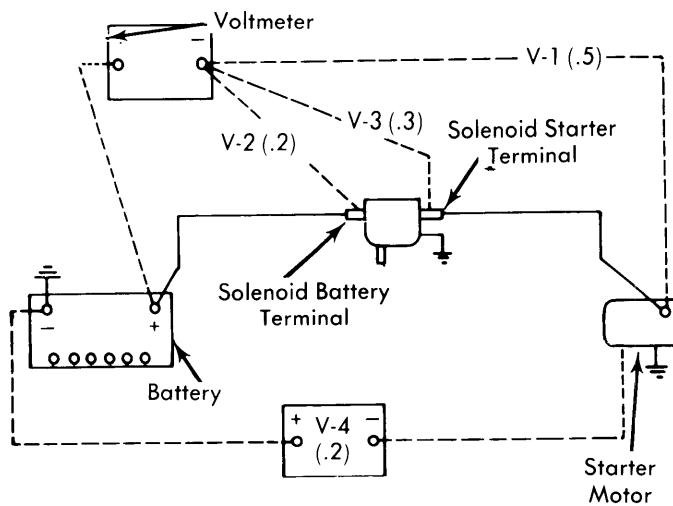

Fig. 1 Connections for Cranking Circuit Test

Battery-to-Starter Motor Voltage Drop (V-1) – Connect voltmeter positive lead to battery positive post and negative lead to starter motor terminal. While cranking engine, note voltmeter reading. Reading should be .5 volt or less. If reading is greater, move negative lead to starter cable at starter and retest. If voltage is now .5 volt or less, remove cable and clean connections, then retest at starter motor terminal. If voltage is still above specifications, test individual cables between battery and starter as follows:

Battery-to-Solenoid Voltage Drop (V-2) – Connect voltmeter positive lead to battery positive post and negative lead to battery terminal of solenoid. While cranking engine, note voltmeter reading. Reading should be .2 volt or less. If reading is greater, remove cable and clean connections, then retest. If reading is still greater, replace cable.

Solenoid Voltage Drop (V-3) – Connect voltmeter positive lead to battery positive post and negative lead to starter CABLE at solenoid. While cranking engine, note voltmeter reading. Reading should be .3 volt or less. If reading is greater, move negative lead to starter TERMINAL at solenoid and retest. If reading is now .3 volt or less, remove and clean cable connector, then retest. If still in excess of .3 volt, replace solenoid. If battery-to-starter circuit (V-1) reading is now greater than .5 volt, replace solenoid-to-starter cable.

Starter Motor Ground Voltage Drop (V-4) – Connect voltmeter negative lead to starter motor housing and positive lead to battery negative post. While cranking engine, note voltmeter reading. Reading should be .2 volt or less. If more, move positive lead to ground cable attaching bolt at engine and retest. If reading is now less than .2 volt, check starter motor for loose mounting bolts, corrosion, or dirt on mounting surface. If reading is now more than .2 volt, examine ground cable for bad connections or bad cable.

STARTER LOAD TEST

Connect a tester and battery into starter circuit (see Fig. 2). Crank engine with ignition coil secondary wire grounded and note voltage on tester. Stop cranking engine and turn load control knob until voltage reading is exactly the same as it was when engine was cranking. Read current draw on ammeter scale. If not within specifications, starter is defective and must be overhauled.

NOTE – Do not take amperage draw reading until starter has obtained maximum RPM.

Load Test Specifications

Application	Amperes
Ford	
4" Starter	160-200
4½" Starter	150-180
Jeep	
6 Cyl.	150-180
8 Cyl.	160-210

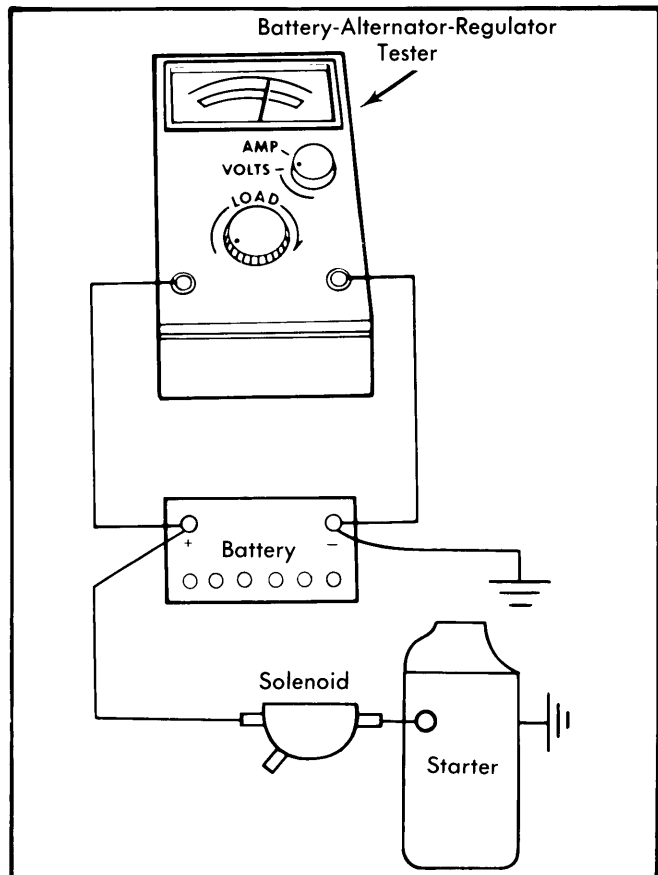

Fig. 2 Connections for Load Test

MOTORCRAFT POSITIVE ENGAGEMENT (Cont.)

STARTER NO-LOAD TEST

With a tester and battery connected to starter (see Fig. 3) operate starter motor and note voltage reading and tachometer reading. Disconnect starter from battery. Turn load control knob until voltage reading is same as when starter is connected. Read the amperage draw, and if amperage reading is less than specifications, starter has high electrical resistance. If starter RPM is less than specifications, worn bushings or bent armature shaft is indicated.

No-Load Specifications

Application	Specifications
Voltage	12 volts
Amperage	67-80 amps.
RPM Range	7380-9600

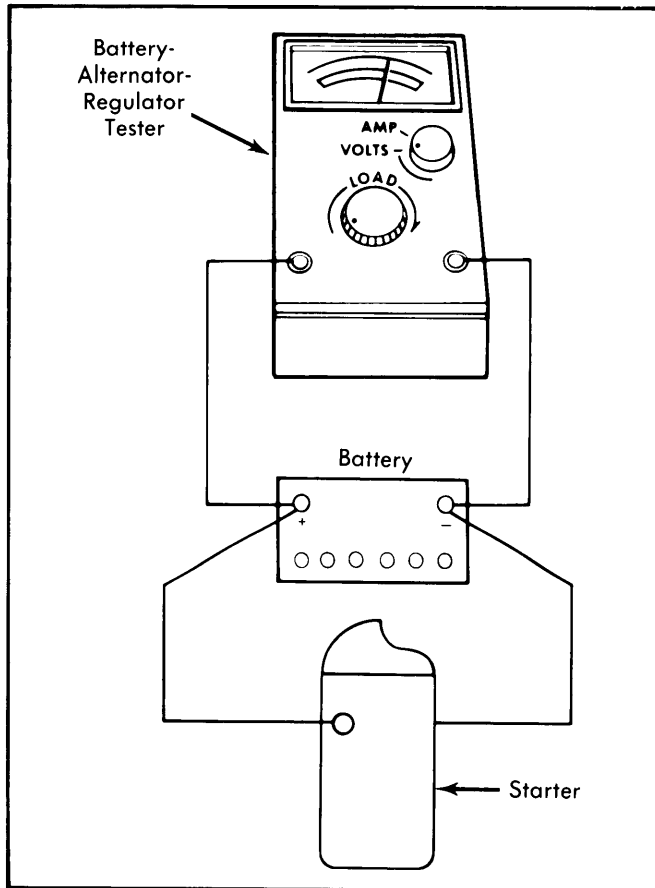

Fig. 3 Connections for No-Load Test

OVERHAUL

DISASSEMBLY

1) Remove brush cover band and starter drive lever cover. Remove brushes from brush holders and note lead positions for reassembly. Remove through bolts, starter drive end housing and starter drive plunger lever return spring. Remove actuating lever pivot pin. Remove lever and slide armature out.

2) Remove stop ring retainer. Remove and discard stop ring retaining starter drive gear to end of armature shaft, then

remove starter drive gear assembly. Remove brush end plate. Remove screws retaining ground brushes to frame. Bend tab up on field coil, which operates drive gear actuating lever, retaining sleeve. Remove sleeve.

3) Remove coil retaining screws. Unsolder field coil leads from terminal screw, remove pole shoes and coils from frame. Unsolder insulated brush leads from field coils. Remove starter terminal nut, washer, insulator, and terminal from starter frame.

PARTS REPLACEMENT & TESTING

Brushes & Springs – Check brush holders for broken springs and insulated brush holders for shorts to ground. Tighten any loose rivets. Replace brushes if worn to 1/4" in length. Measure spring tension with spring scale hooked under spring near end, pull on line parallel to edge of brush and note the reading just as spring end leaves brush. Spring tension should be 40 ozs. If replacing brushes, use a 300 watt soldering iron and rosin core solder.

Armature – Check armature for shorted coils with a growler. Test for grounded coils using a test light, or a voltmeter and battery connected in series by touching one test probe to commutator and other test probe to core or armature shaft. If test light glows, or voltmeter shows any reading, coils are grounded. Inspect armature shaft and two bearings for scoring or excessive wear. Inspect armature windings for broken or burned insulation and unsoldered connections. If commutator is rough or more than .005" out of round, reface in a lathe removing only enough material to provide a smooth, even surface.

Field Coil Assembly – Inspect the field coils for burned or broken insulation and continuity. Check field brush connections and lead insulation. To check for grounded field windings, connect a voltmeter to starter (see Fig. 4). If voltmeter indicates any voltage, field windings are grounded. **NOTE** – Both field brushes and holding coil ground lead must be kept away from frame during this test and holding coil ground lead disconnected.

REASSEMBLY

1) Install starter terminal, insulator, washers, and retaining nut. **NOTE** – Position slot in screw perpendicular to frame end surface. Position coils and pole pieces with coil leads in terminal screw slot, then install retaining screws. As screws are tightened, strike frame several sharp blows with soft-faced hammer to seat and align pole shoes, then stake screws.

2) Install solenoid coil and retainer, bend tabs to retain coils on frame. Solder field coils and solenoid wire to starter terminal using rosin core solder. Check for continuity and grounds in assembled coils. Position new insulated brush leads on field coil terminal while using clip provided with brushes to hold brush leads to terminal. Solder lead, clip, and terminal with rosin core solder.

3) Position solenoid coil ground terminal on nearest ground screw hole, position both ground brushes and install attaching screws. Position commutator end plate on frame with end plate boss in frame slot. Apply thin coating of lubricant on armature shaft splines, install drive assembly on shaft, then in-

Starters

MOTORCRAFT POSITIVE ENGAGEMENT (Cont.)

Install new stop ring and retainer. Position fiber thrust washer on commutator end of armature and position armature in starter frame.

4) Position starter drive gear plunger lever to frame and starter drive assembly, install pivot pin. Partially fill drive end housing bearing bore with grease (approximately $\frac{1}{4}$ full). Position drive plunger lever return spring and drive end hous-

ing to frame, install and tighten through bolts to 55-75 INCH lbs. **CAUTION** – Do not pinch brush leads between plate and frame. Make sure stop ring retainer is seated properly in drive housing.

5) Install brushes in brush holders, centering springs on brushes. Position drive gear plunger lever cover on starter and install brush cover band with a gasket. Tighten band retaining screw. Check starter no-load current draw.

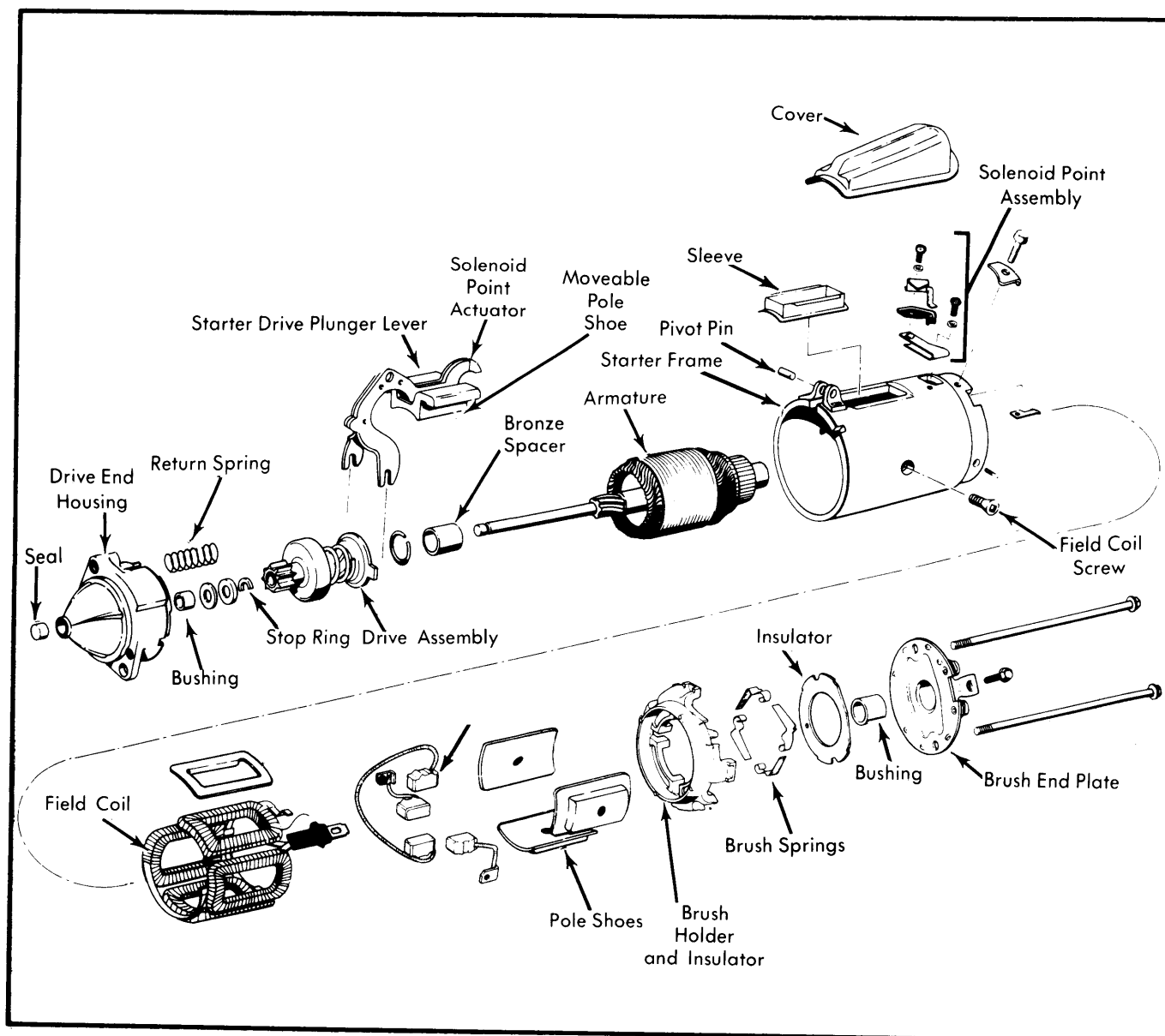

Fig. 4 Exploded View of Starter Motor Assembly