

HITACHI REGULATOR

International Harvester
6 Cyl. Diesel Models

DESCRIPTION

The regulator system consists basically of a voltage regulator and a charge relay. The voltage regulator has a lower contact, an upper contact, and a moving contact. The moving contact is placed between the upper and lower contacts. This moving contact moves upward, downward, or vibrates. The lower contact, when closed, completes the field circuit direct to ground. The upper contact, when closed, completes field circuit to ground through a resistance (field coil), and thereby controls alternator output. The charge relay is similar in construction to voltage regulator. When upper contacts are closed, the charging warning light is on.

APPLICATION

Model	Hitachi No.
6 Cyl. Diesel	TL1Z-41

ADJUSTMENT

- 1) Disconnect and remove voltage regulator and charge relay from vehicle. Remove covers and if contact points are rough, smooth them with fine sand paper. Check core gap, then point gap of voltage regulator and charge relay. If not within specifications, adjustment is necessary.
- 2) Adjust core gap by loosening screws attaching contact set to yoke. Move contact set upward or downward as required. Adjust point gap by loosening screw attaching upper contact. Move upper contact up or down as required to set gap to specification.

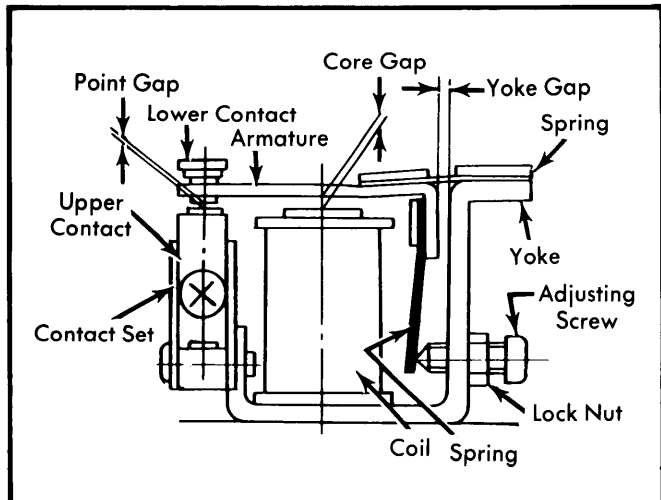

Fig. 1 Checking Voltage Regulator Gaps
(Charge Relay is Similar)

TESTING

CAUTION — Disconnect voltage regulator and charge relay from circuit if removal of cover or changing of adjusting screw setting is necessary to prevent shorting system.

VOLTAGE REGULATOR

Connect a voltmeter to enable the reading of battery voltage. Start engine and allow to run at 2500 RPM. If regulated voltage is not within specifications, adjustment is required. To adjust, loosen lock nut and turn adjusting screw in if voltage is high, or out if voltage is low. Tighten lock nut.

CHARGE RELAY

Insert a voltmeter, variable resistor, and switch into circuit as shown in illustration. Set the resistance of rheostat at maximum, close switch and slowly decrease resistance. The operating voltage of the charge relay will be found when the charge light goes out. If the operating voltage is not within specifications, adjust in the same manner as voltage regulator.

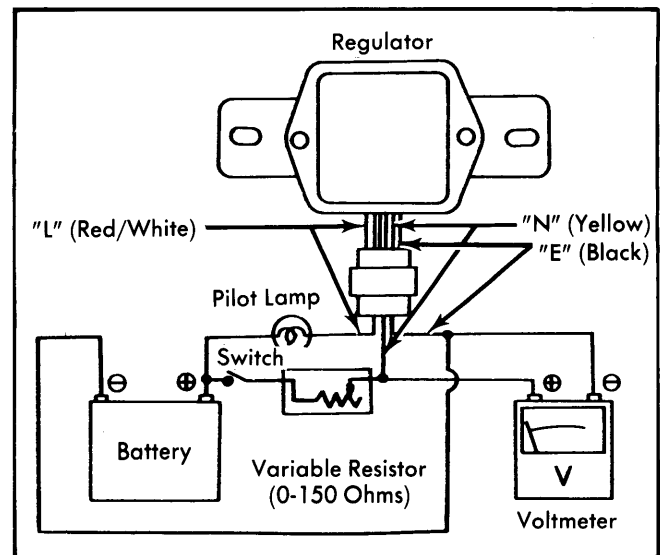

Fig. 2 Measuring the Charge Relay Operating Voltage

Voltage Regulator Specifications

Application	Specification
Regulated Voltage	13.8-14.8 V.
Yoke Gap	Not Adjustable
Core Gap024-.039"
Point Gap012-.016"

Charge Relay Specifications

Application	Specifications
Operating Voltage	4-5 V.
Voltage Coil Resistance	31.9 Ohms
Yoke Gap	Not Adjustable
Core Gap031-.039"
Point Gap012-.016"