

## GENERAL MOTORS

Chevrolet  
GMC

### DESCRIPTION

#### DOOR WINDOWS

Window regulators are individually powered by a reversible electric motor located in each door. The motor, secured to the regulator assembly, contains an internal circuit breaker and a self-locking gear drive. Two way switches, located on each door, with a master control switch located on left door, control window operation.

#### CIRCUIT BREAKER

Circuitry and wiring for power equipment is protected by a 40 Amp circuit breaker of the plug in type. It is mounted on the fuse panel for all GM divisions.

#### CONTROL SWITCHES

In addition to individual control switches adjacent to individual windows, a master control switch is mounted on the left door trim pad.

#### IGNITION RELAY

A relay is used in the window circuit to prevent operation until ignition is turned on. Relay is located on steering column lower support.

#### ACCESSORY JUNCTION BLOCK

Located on the reinforcement at the left shroud and used to supply current to power operated circuits. Current is supplied to junction block from the circuit breaker. The power window harness plugs into the junction block.

### TROUBLE SHOOTING

#### WINDOWS WILL NOT OPERATE WITH IGNITION ON

Open circuit or short in power feed circuit. Switch defective.

#### RIGHT WINDOW OPERATES WITH MASTER SWITCH BUT WILL NOT OPERATE WITH RIGHT CONTROL SWITCH, LEFT WINDOW OPERATES

Open circuit or short in front harness feed circuit.

### TESTING

#### CIRCUIT BREAKER

Check power feed to circuit breaker, with no power available, feed wire is open or shorted. Test breaker output terminal, if power fails, breaker is inoperative

#### IGNITION RELAY

Test relay feed Orange/Black wire for voltage, without voltage available, check wire leading to circuit breaker. Turn ignition "ON" and test relay Red/White wire terminal. If power fails, test relay coil voltage Pink/Black wire terminal. If power is now available, replace relay. If power fails, check circuit along Pink/Black wire and check fuse.

#### MASTER CONTROL SWITCH

Check power feed Red/White wire at switch, if power fails, test wire between relay and master switch.

#### WINDOW CONTROL SWITCH

1) Connect one lead of test lamp to switch connector feed wire and ground other lamp lead. If lamp does not light, an open short circuit exists between switch and power source.

2) Insert one end of a jumper wire in switch connector and other end of jumper to motor lead in connector. Repeat procedure for motor lead terminal. If motor operates with jumper wire but does not operate with switch, replace switch.

#### WINDOW SWITCH TO WINDOW HARNESS

Disconnect harness connector from motor. Insert one end of a jumper wire in switch connector and other end of jumper to motor lead in connector. Using a test lamp, check for current at motor connector. If lamp does not light, switch to motor harness is shorted or has open circuit. Check other terminal using same procedure.

#### WINDOW MOTOR

Check Power feed to motor terminals, if power is available, check motor ground. Inspect window regulator and channels for possible binding. Connect a jumper wire to the other motor terminal. Motor should operate window up and down, if not, replace motor.

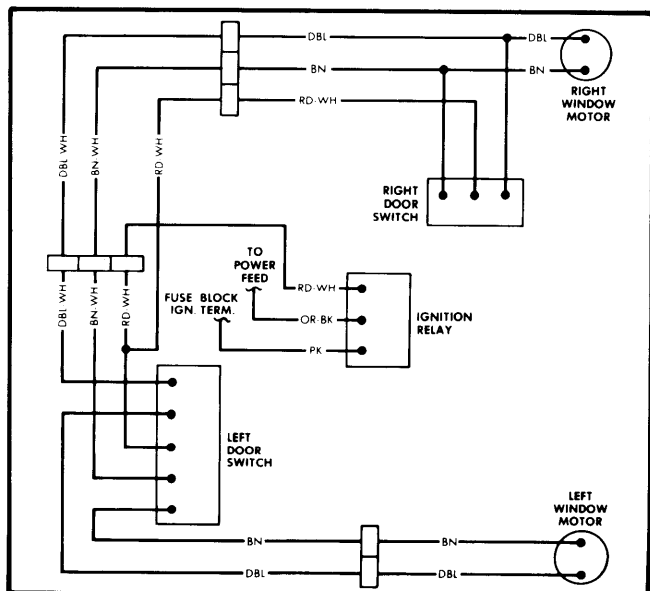

Fig. 1 General Motors Light Truck  
Power Window Wiring Diagram

## GENERAL MOTORS (Cont.)

### REMOVAL & INSTALLATION

#### WINDOW REGULATOR MOTOR

- 1) Disconnect battery ground cable and remove door trim panel, arm rest and pull assist brackets.
- 2) Remove glass outer seal and glass run channel
- 3) Remove regulator attaching nuts and screws, pull glass to the limit, turn approximately 90° and remove glass from door.
- 4) Disconnect harness from regulator and rotate motor regulator approximately 90° to access hole.
- 5) Drill hole through sector gear and back plate and install a screw in the hole to lock the sector gear in position. **CAUTION** – Sector gear must be locked when removing regulator to preclude injury from the counterbalance spring. Remove motor from regulator.
- 6) To install, reverse removal procedures insuring that water proof tape is applied to seal all holes.

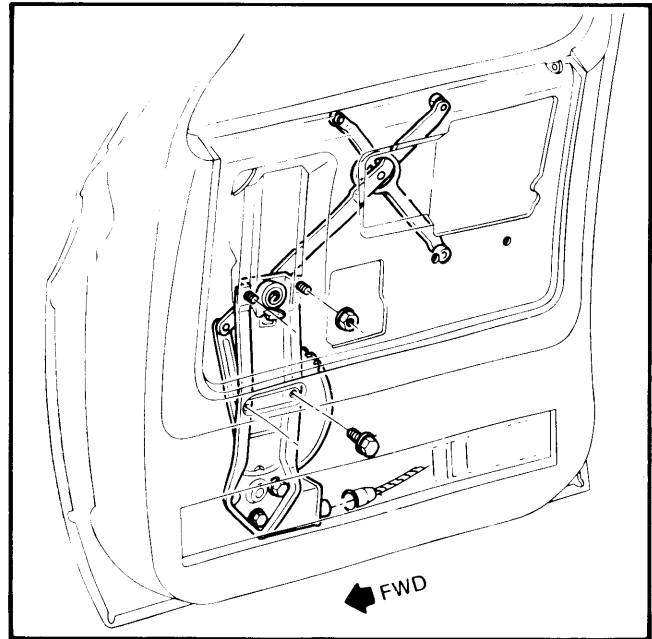

Fig. 2 General Motors Power Window Regulator, Motor and Connector