

# Turn Signal & Hazard Flasher Systems 6-39

## ALL MANUFACTURERS

### DESCRIPTION

Turn signal and hazard flasher circuits are integral systems using a common switch assembly mounted within upper steering column housing. Signal lever is on left side of column and hazard switch knob is on right side. Two different flasher units are used. The hazard flasher is a variable load type and will operate regardless of the number of lights burned out.

If one signal light is burned out, the signal circuit will not function on same side due to insufficient current draw to operate flasher

**NOTE** — For wiring diagrams of individual models, refer to chassis wiring diagrams in **WIRING DIAGRAM** Section.

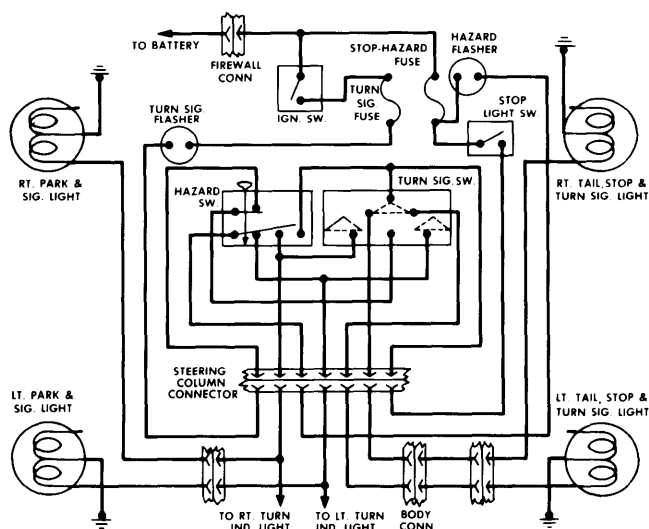

Fig. 1 Wiring Diagram of Typical Turn Signal and Hazard Flasher System

### OPERATION

**Turn Signals** — Signal systems operate only when ignition switch is turned on. Normal frequency of signal lights are about 60-120 flashes per minute. Switch has two detent positions for each signal direction. With signal lever in first detent, lights will blink, but will go off if switch lever is released. Second switch detent will hold signal on, until steering wheel canceling fingers automatically turn signal off.

**Hazard Flasher** — With knob activated, all park and stop lights flash simultaneously regardless of ignition switch position. Depressing brake pedal will override flasher operation until pedal is released. During hazard switch operation with some vehicles, the turn signal should be off to avoid electric feed back through accessory circuits causing intermittent operation of circuits left turned on.

### FLASHER LOCATION

#### CHRYSLER CORP.

**Hazard** — Plug-in type located in the fuse box.

**Turn Signal** — Plug-in type located in the fuse box.

#### FORD MOTOR CO.

**Hazard** — Located on right side of the hub taped to the wiring harness.

**Turn Signal** — Mounted on left side of cowl.

#### GENERAL MOTORS

**Hazard** — Mounted on the fuse block.

**Turn Signal** — Mounted on the fuse block.

#### INTERNATIONAL HARVESTER

**Hazard** — Mounted on the fuse panel.

**Turn Signal** — Mounted on rear of dash above fuse panel.

#### JEEP CORP.

**Hazard** — Mounted on the fuse panel.

**Turn Signal** — Mounted on the fuse panel.

### TESTING

**CAUTION** — If equipped with Air Cushion Restraint System, do not attempt any service on turn signal switch until ignition switch is in "LOCK" position and battery ground cable is disconnected and taped.

### TURN SIGNAL & HAZARD SYSTEM

**Turn Signals Inoperative** — Turn on hazard system, if all lights operate, inspect for blown turn signal fuse or defective flasher. If fuse is open, check for shorts between fuse and lamps. If turn signal fuse and flasher are satisfactory, check wire terminals in harness connector for continuity and power feed to and from switch. To determine if switch is bad, connect a known good switch in column to chassis connector and operate switch by hand. If signals now operate, replace switch.

**Turn Signals Inoperative (One Side)** — Turn on hazard system, if one or more lights are inoperative, replace lights as necessary. Test light sockets for power or poor ground connection. If all lights operate with hazard system on, inspect for improper lamp or inoperative turn signal switch. If turn signal flasher can be heard, but lights fail, check for a short circuit.

**Hazard Flasher Inoperative** — Turn on signal switch, check all lights, and service as required. Check power to hazard circuit fuse and test fuse. If fuse is blown, check for shorts and/or replace fuse. If fuse is satisfactory, check power to hazard flasher. Replace with a good flasher, if system still fails. Check power to hazard switch in steering column. Repair circuit between hazard flasher element and switch if necessary. To determine if switch is at fault, connect a known good switch in column to chassis connector and operate switch by hand. If hazard system now operates, repair or replace switch.

### REMOVAL & INSTALLATION

#### TURN SIGNAL & HAZARD SWITCH ASSEMBLY

See *Steering Wheel, Horn Button & Turn Signal Switch Removal* in **STEERING** Section. **CAUTION** — If equipped with Automatic Speed Control, do not remove lever from steering column.