

GENERAL MOTORS

Chevrolet
GMC

DESCRIPTION

All instruments and gauges are installed in the instrument cluster and "C" & "K" models can be serviced in the vehicle. "G" models require removal of the entire instrument cluster from the vehicle prior to servicing. Indicator lamps and illuminating bulbs may be replaced on all models without removing instrument cluster from vehicle.

TESTING

INDICATOR WARNING LIGHTS

Oil Pressure Indicator – 1) Indicator light is inoperative with ignition switch on and engine not running. Check for burned out bulb, open light circuit or defective oil pressure switch.

2) Indicator light is on and engine is running. Indicates low oil pressure, defective oil pressure switch or short between light and switch.

Temperature Indicator – 1) If "HOT" indicator light is inoperative when cranking engine, check for burned out light bulb, open light circuit or a defective ignition switch.

2) When light is on with engine running, check for coolant temperature above 258°F., short between light and switch, defective temperature or ignition switch.

Charging System Indicator – 1) If light is inoperative with ignition in "ON" position before starting engine, check for burned out bulb or short in wiring.

2) If light is on with engine running, check for loose or missing belt, or short in the circuit. If good, check alternator (generator) and regulator for proper output.

FUEL GAUGE

Use a suitable Gas Gauge Tester (J-22344 or equivalent). Disconnect feed wire from the gas gauge tank terminal and connect one test lead to the wire and ground the other lead. Switch tester to "EMPTY" and "FULL" positions and fuel gauge should read the same as the tester. If not, proceed with the following tests with ignition in "ON" position.

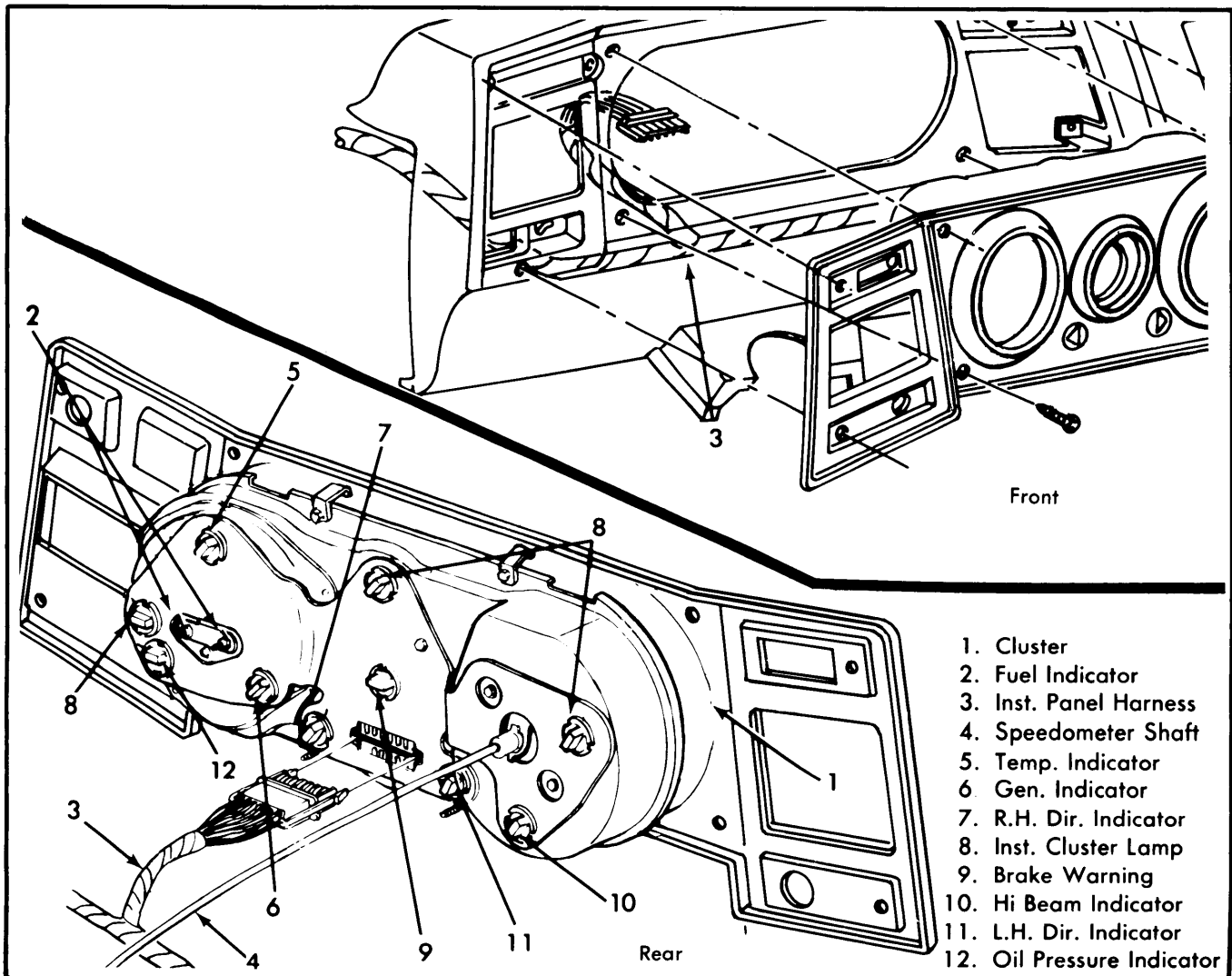

Fig. 1 General Motors "G" Models Instrument Cluster

Switches, Gauges & Instrument Panels 6-33

GENERAL MOTORS (Cont.)

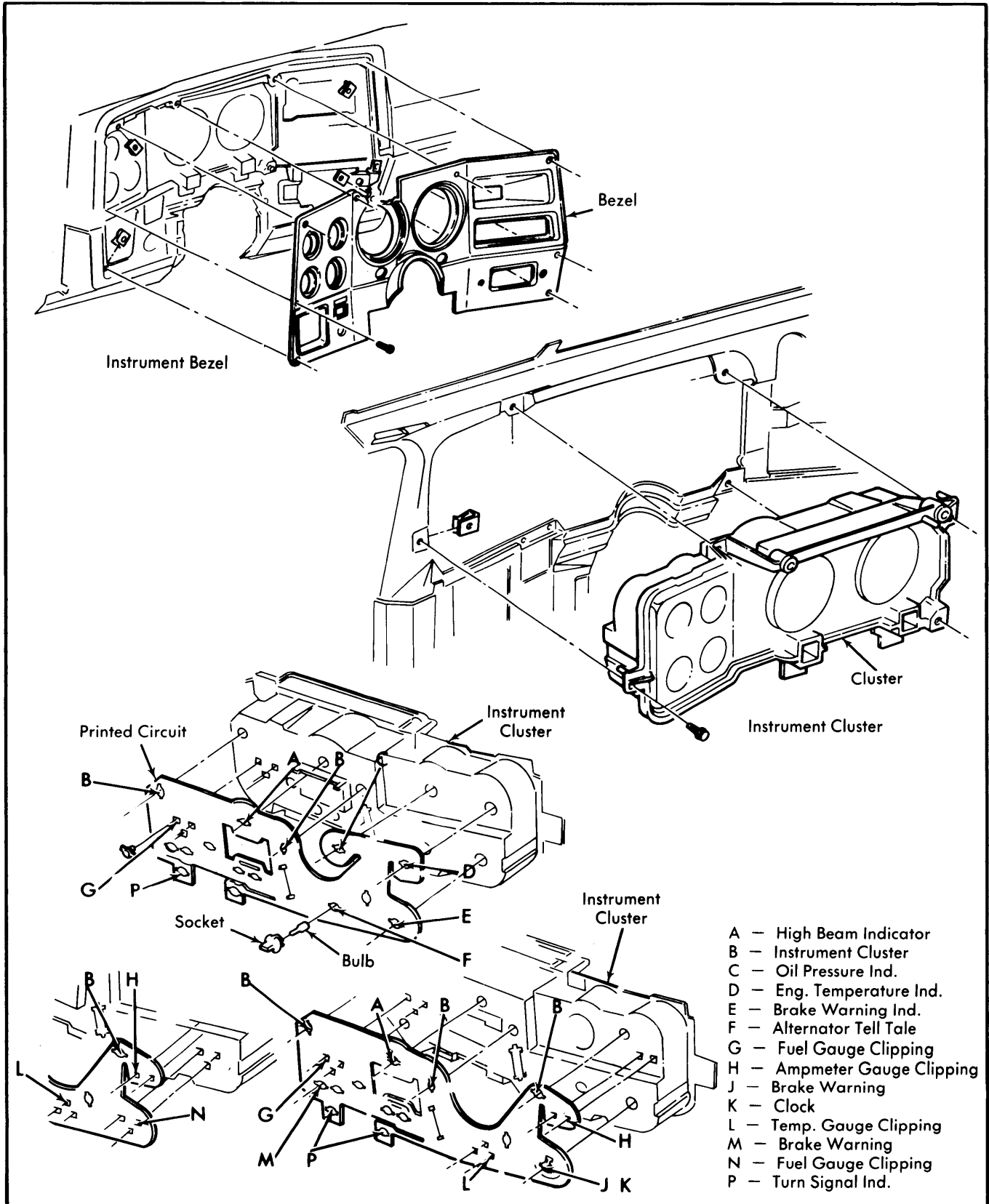

Fig. 2 General Motors "C" & "K" Models Instrument Cluster

6-34 Switches, Gauges & Instrument Panels

GENERAL MOTORS (Cont.)

Gauge Never Reads Empty or Reads Full At All Times – Check for disconnected or loose tank unit feed wire at tank. If good, check for proper connections at the printed circuit.

Gauge Always Reads Empty – Disconnect tank unit feed wire and gauge should indicate full. If not at "FULL" position, check connections to printed circuit or for an open in the printed circuit.

Gauge Never Reads Full – Check system with Gas Gauge Tester, positioned in line between feed wire and tank terminal. If gauge reads full, fill the gas tank. Using an ohmmeter, check resistance of tank sending unit which should read between 88 and 92 ohms. If ohm reading is low, check tank mounting area for damage. If gauge does not read full, check connections to printed circuit or for an open within the printed circuit.

Gauge Dead – Check feed wire voltage to the tank which should read 3-4 volts. If it does not, check for open on hot side of the gauge, or proper connections at the printed circuit. If voltage is correct, remove and check fuel gauge.

OIL PRESSURE & TEMPERATURE GAUGE

Both gauges show actual readings and require a minimum of maintenance. The oil pressure gauge uses a direct tube from engine to gauge and if it becomes restricted, remove tube at both ends and blow out the line. The temperature gauge is electric and uses a sending unit to transmit engine temperature. Do not repair either unit, replace units when required.

AMMETER GAUGE

If gauge fails to read correctly, test charging system. See *Delco-Remy Alternators in ELECTRICAL Section for testing procedures.*

REMOVAL & INSTALLATION

SPEEDOMETER & GAUGES

All Models – All instruments and gauges are installed in the instrument cluster. Instrument cluster must be removed from vehicle for replacement of components.

INSTRUMENT CLUSTER

"C" & "K" Models – 1) Disconnect battery ground cable. Remove instrument cluster bezel and steering column cover screws, bezel and cover.

2) Remove clock knob (if equipped), lens retaining screws and lens. Remove transmission quadrant indicator retaining screws and remove indicator. Remove cluster retainer.

3) Reach up under dash and disconnect speedometer cable by depressing spring clip, and pull out cable. Disconnect oil pressure line (if equipped). Disconnect cluster wiring harness, remove cluster retaining screws and cluster. Move cluster assembly to suitable work area for further disassembly.

4) To install, reverse removal procedure.

"G" Models – 1) Disconnect battery ground cable. Reach up under instrument cluster and disconnect speedometer cable by first depressing tang on rear of speedometer head and pushing, then pulling cable free from head as tang is depressed.

2) Unplug electrical harness connector from printed circuit. Disconnect oil pressure line from gauge (if equipped) and remove two nuts attaching instrument cluster studs to lower opening in instrument panel, and lift out bottom of cluster. Remove cluster to suitable work area for further disassembly.

3) To install, reverse removal procedure.

PRINTED CIRCUITS

All Models – 1) Remove instrument cluster, all cluster light assemblies and printed circuit retaining screws.

2) Remove fuel, temperature and ammeter terminal nuts holding printed circuit to cluster cover. Remove printed circuit from rear of instrument cluster.

3) To install, reverse removal procedure while noting that retaining screws serve as ground for printed circuit and must be properly reinstalled to provide proper ground connection.

HEADLIGHT SWITCH

All Models – 1) Disconnect battery cable. Reach up behind instrument cluster and depress shaft retaining button to remove switch knob and rod. Remove instrument cluster switch retaining nut and push switch from panel opening, then remove electrical connections at switch terminals.

2) Reinstall by reversing removal procedures. Insure ground wire is reinstalled where applicable.