

JEEP CRUISE COMMAND

Jeep
Cherokee
Wagoneer
"J" Models

DESCRIPTION

System senses car speed through speedometer cable and uses engine intake manifold vacuum to regulate accelerator and automatically maintain any pre-set cruising speed between 30 and legal speed limit.

OPERATION

Cruise Command control is an integral part of the directional switch lever and consists of two separate switches. The first is "OFF-ON" and "RES" (resume) slide switch located on the flat of directional switch lever. Second is a push button switch located at the end of directional switch lever. To engage system, move slide switch to "ON" position and accelerate to desired speed. Depress and release button on end of switch lever. System will now maintain selected speed. System will automatically disengage when brake pedal is depressed and can be re-engaged to previously selected speed by accelerating to 30 MPH and moving slide switch to "RES" position, then releasing switch.

NOTE — When slide switch is moved to "OFF" position, Pre-set speed of "RES" function is canceled and must be reset when system is reactivated.

A higher speed can be set by pressing on accelerator pedal until new speed is reached and then pushing control button. A lower speed can be achieved by lightly depressing brake pedal, allowing vehicle to slow to desired speed and then depressing pushbutton. Operation of individual components is as follows:

Regulator — Senses speed through speedometer cable located between transmission and regulator. Fly-weight type governor reacts to cable speed and engages low speed switch at approximately 30 MPH. When low speed switch is closed, driver may engage system. Regulator is serviced as an assembly.

Vacuum Servo — A neoprene bellows that receives modulator vacuum and actuates throttle to control vehicle speed.

Control Switch — An integral part of turn signal lever, when actuated it will energize either solenoid valve or coupling coil (or both), thereby controlling speed.

Release Switch — Disengages system when brake pedal is depressed.

TROUBLE SHOOTING & DIAGNOSIS

SYSTEM WILL NOT ENGAGE

System harness fuse blown. Defective brake light switch. Vacuum leak. Bad regulator ground or electrical connections. Brake light fuse or lamp burnt out. Defective engaging switch or regulator. No current to brown wire.

SYSTEM DOES NOT DISENGAGE WHEN BRAKES APPLIED

Defective brake light switch or collapsed servo-to-regulator hose.

SYSTEM RE-ENGAGES WHEN BRAKES RELEASED

Defective engagement switch. Improper location of wiring in connectors.

CARBURETOR DOES NOT RETURN TO NORMAL IDLE, PULSATING ACCELERATOR PEDAL

Throttle chain linkage adjustment incorrect. Lack of lubrication or kinked speedometer or drive cable.

SPEEDOMETER INOPERATIVE, SYSTEM STILL OPERATES

Speedometer not driven by cable. Defective regulator.

SPEEDOMETER & SYSTEM INOPERATIVE

Transmission cable not driving regulator.

SPEED 3 OR MORE MPH ABOVE OR BELOW SELECTED SPEED

Adjustment of regulator incorrect.

ENGINE ACCELERATES WHEN STARTED

Vacuum hoses at regulator reversed.

SYSTEM DISENGAGES ON LEVEL ROAD WITHOUT APPLYING BRAKE

Loose electrical connections or ground. Loose hoses. Broken servo linkage chain. Slipped throttle clevis.

ERRATIC OPERATION OF SYSTEM

Inspect vacuum servo or vacuum hoses. Inspect regulator.

TESTING

All tests of system should be performed as part of diagnosis of malfunction and to determine procedure(s) required for system repair. Four separate circuits are used in system. These circuits are: slide switch in "ON" position, slide switch in "RES" position, pushbutton depressed and, brake release.

NOTE — Whenever a unit is disconnected for testing, it should be reconnected before next unit is tested.

CONTROL SWITCH CONTINUITY

Control switch continuity test is performed at steering column using an ohmmeter. Refer to following chart to determine switch continuity condition.

NOTE — Pushbutton cannot be depressed with slide switch in "RES" position.

JEEP CRUISE COMMAND (Cont.)

Control Switch Continuity Conditions

Application	Switch Position	Condition
Red-to-Brown	"OFF"	Open
Red-to-Green	"OFF"	Open
Red-to-Yellow	"OFF"	Open
Red-to-Brown	"ON"	Closed
Red-to-Green	"ON"	Closed
Red-to-Yellow	"ON"	Open
Red-to-Brown	"RES"	Closed
Red-to-Green	"RES"	Closed
Red-to-Yellow	"RES"	Closed
Red-to-Brown	"ON"⓪	Closed
Red-to-Green	"ON"⓪	Open
Red-to-Yellow	"ON"⓪	Closed

⓪ — Pushbutton depressed.

ELECTRICAL TESTS

NOTE — If system is inoperative, it is not always necessary to remove regulator.

1) Disconnect both single and triple push-on connectors at regulator. Turn ignition switch to "ACC" and move slide switch to "ON" position. Perform the following tests using a suitable test lamp.

2) Ground one test lamp lead and touch other to brown wire and then green wire at connectors. Test lamp should light at both wires. If lamp does not light at brown wire, check fuse, speed control relay, engagement switch or power source connection. If lamp does not light at green wire, check brake light switch, engagement switch, speed control relay or power source connection.

3) Hold "SET SPEED" button all the way in. Ground one test lamp lead and touch other to each wire in connector. Lamp should light at brown and yellow wires and should not light at green or blue wires. Release "SET SPEED" button.

4) Hold slide switch in "RES" position. Ground one test lamp lead and touch other to each wire in connector. Lamp should light at all wires except blue wire. Blue wire connects to turn signal side of turn signal switch.

NOTE — The following tests need not be done if preceding tests checked out. If the preceding tests did not check out, perform the following tests.

5) Disconnect engagement switch from wiring harness at multiple connector in passenger compartment. Attach a jumper wire from a 12 volt power source to engagement switch red lead.

6) Move slide switch to "OFF" position. Ground one test lamp lead and touch other (in turn) to brown wire, green wire and then yellow wire. Lamp should not light at any wire.

7) Move slide switch to "ON" position. Ground one test lamp lead and touch other to brown wire and then green wire. Lamp should light on both wires. Touch test lamp lead to yellow wire. Lamp should not light.

8) Hold "SET SPEED" button all the way in. Ground one test lamp lead and touch other to brown wire and yellow wire. Lamp should light on both wires. Touch test lamp lead to green wire. Lamp should not light. Release "SET SPEED" button.

9) Hold slide switch in "RES" position. Ground one test lamp lead and touch other (in turn) to brown wire, yellow wire and then green wire. Lamp should light at all wires. Release slide switch.

NOTE — If test procedures 1) through 4) do not check out, but procedure 5) through 9) do check out, replace Cruise Command system wiring harness. If all test procedures do not check out, replace engagement switch.

BRAKE RELEASE SWITCH TEST

NOTE — The brake release switch is part of the stoplamp switch. The stoplamp circuit must be operating correctly before testing brake release switch.

Disconnect triple wire connector at regulator. Using a suitable test lamp, ground one test lamp lead and touch other to blue wire. Lamp should not light. With brake pedal depressed $\frac{1}{4}$ ", test lamp should light. If lamp does not light, check fuse, stoplamp switch, wire harness to regulator or power source connection.

SPEED CONTROL RELAY TEST

1) The speed control relay is mounted next to system regulator. Check all electrical connections before testing relay. Turn ignition switch on and move slide switch to "ON" position. Using a suitable test lamp, ground one test lamp lead and touch other to each connector at relay. Test lamp should light at each connector.

2) If test lamp lights on the white and violet connectors but does not light on red connector, replace relay. If test lamp does not light on white and violet connectors, check fuse, wiring harness and power source connection.

ADJUSTMENT

VACUUM SERVO CHAIN

NOTE — Prior to adjusting servo chain, carburetor throttle must be at idle position, throttle stop solenoid disconnected and choke valve fully open.

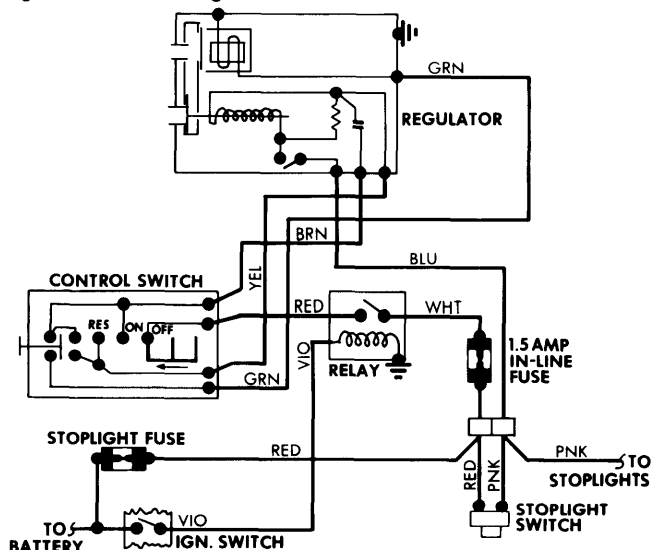

Fig. 1 Jeep Cruise Command System Wiring Diagram

JEEP CRUISE COMMAND (Cont.)

To install vacuum servo chain, insert chain in vacuum servo hook. Stretch chain linkage to carburetor until chain is fully extended and clevis pin hole aligns with hole in throttle lever. If holes do not line up, adjust chain at servo hook (one ball at a time) until free pin fit is obtained. When properly adjusted, there should be a slight deflection in chain without moving either carburetor throttle lever or servo. After adjustment, bend servo hook tabs together. **NOTE** — Chain must be free in hook after bending tabs.

CENTERING SPRING

NOTE — Adjustment of centering spring is extremely sensitive. Adjustment screw must never be turned more than $\frac{1}{8}$ turn in either direction.

Cruise command system is designed to maintain speed designated by driver, within 3 MPH. System operation is checked at 50 MPH. Speed change is made by adjusting spring centering screw. If speed control holds speed more than 3 MPH above designated speed, turn centering spring screw "C" (see illustration) toward "S", $\frac{1}{32}$ " of a turn or less. If speed is

more than 3 MPH below designated speed, turn centering speed screw "C" toward "F", $\frac{1}{32}$ " of a turn or less.

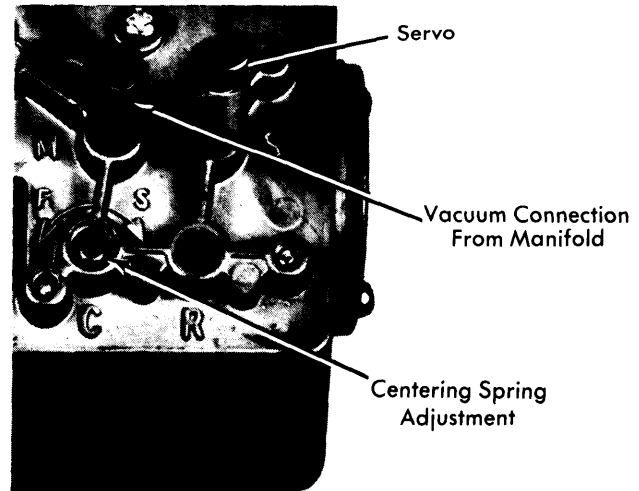

Fig. 2 Identification of Adjustment Screw