

COMPRESSOR OIL CHECK

GENERAL NOTES

AIR TEMP, TECUMSEH & YORK COMPRESSORS

Oil level on these compressors may be checked with compressor mounted in vehicle. If these compressors are equipped with stem-type service valves, compressor may be "isolated", thereby avoiding necessity of discharging entire system.

NOTE— See *Compressor Isolating* or related paragraphs in this Section.

FRIGIDAIRE COMPRESSORS

When checking oil level on these compressors, it may be necessary to remove compressor from vehicle, as filler plug is located near the bottom of the compressor. After oil level is checked, air conditioning system must be evacuated and recharged before it can be put back into service.

NOTE— See *Frigidaire Compressor* in this Section.

COMPRESSOR ISOLATING

On York and Tecumseh compressors which have stem-type service valves (at compressor suction and discharge ports), it will not be necessary to discharge the entire system in order to open the compressor for oil checking (or other compressor service).

NOTE— See *York & Tecumseh Compressors and Compressor Replacement* in this Section.

REFRIGERATION OIL

Only new, pure, moisture-free refrigeration oil should be used in the air conditioning system. This oil is highly refined and dehydrated (moisture content less than 10 parts per million) to a point well below contamination factor. Refrigeration oil container must be kept tightly closed at all times when not in use, or moisture will be absorbed from the air and introduced into the refrigeration system.

AIR-TEMP COMPRESSOR

CHRYSLER CORP.

Oil level need not be checked each time system is discharged unless all refrigerant charge has been lost or significant oil loss is otherwise suspected. Quantity of oil in the compressor is measured by checking height of oil level from bottom of compressor sump. Use one of the following methods (as applicable):

Standard Oil Level Check — 1) Slowly discharge system. This will not allow oil to escape with refrigerant. Near completion of discharge, oil dipstick (see Fig. 1) should be flushed with freon. This will insure a cool, clean dipstick.

2) Slowly remove compressor crankcase filler plug; some residual pressure will remain in the crankcase after system discharge. Insert oil level dipstick until it bottoms in sump. Oil level on stick must be $2\frac{3}{8}$ ". If necessary, add recommended oil to bring level to specification. Do not exceed specified amount.

Checking Oil After System Discharge — If system discharge is accomplished using fast discharge method (with oil collector can attached to center discharge hose), measure amount of oil retained in can. Replace this same amount with new oil. Also, if any of the following components are replaced, add specified additional amounts of oil:

Evaporator	2 oz.
Condenser	1 oz.
Receiver-Drier	1 oz.

After this is completed, use standard dipstick method to determine exact oil level before recharging system.

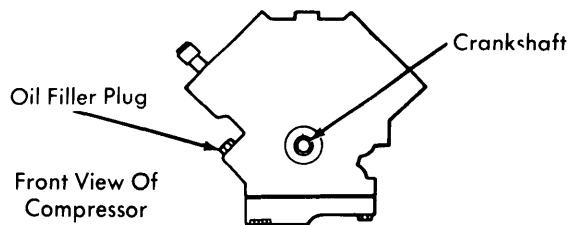
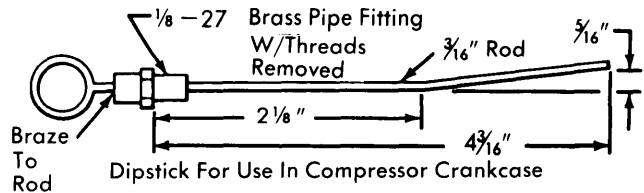

Fig. 1 Air-Temp Compressor Oil Check Point and Dipstick For Chrysler

FRIGIDAIRE COMPRESSOR

GENERAL MOTORS W/6 CYLINDER COMPRESSOR

The standard A/C system with the 6 cylinder compressor is fully charged with 10.5 ounces of refrigerant oil while models equipped with optional overhead A/C system are fully charged with 13 ounces of refrigerant oil. Adding additional oil is not normally required unless a definite oil loss has occurred due to a ruptured line, leaking compressor seal, replacement of system component, compressor overhaul, or loss due to collision.

On-Car Checking After Minor Repairs — 1) Start engine and allow to idle with A/C on maximum cold. Run engine under these conditions for approximately 10 minutes. Turn off engine and momentarily crack open compressor fill plug allowing a small amount of oil to drain out. Tighten plug then again crack open momentarily. If oil again starts to come out, compressor has the required amount of oil. It is normal for oil to appear foamy.

2) Oil can be added without removing compressor by using a special oil injector or by using the A/C service station as recommended by manufacturer. If these are not available, compressor must be removed and correct amount of oil added.

COMPRESSOR OIL CHECK (Cont.)

Off-Car Checking After Major Repair – 1) Before performing repairs, if system is operable, run A/C for several minutes to stabilize system. Turn off air conditioner and engine, discharge system completely, and remove compressor. Slowly remove oil drain plug, then drain and measure oil from compressor, and replace amounts as outlined below. If new compressor is being installed, drain and measure oil from old compressor and add new oil to replacement compressor using described method below; if compressor is being overhauled, add one additional ounce of oil to amount being replaced.

2) If quantity drained is less than 4 ounces, add 6 ounces of replacement oil. If quantity drained is between 4 and 6 ounces, oil is properly distributed throughout the system; add same amount as drained. If quantity drained is more than 6 ounces, add ONLY 6 ounces

NOTE – Remember....DO NOT reuse old oil; add only new refrigerant oil to system.

3) If compressor is inoperable, use the following method: Remove compressor, drain, measure, and discard the oil. If amount drained is more than 1½ ounces, and the system shows no sign of a major leak, add amount drained. If less than 1½ ounces is drained and system appears to have lost excessive oil, add 6 ounces to replacement compressor, or 7 ounces if compressor is being overhauled.

4) When repairing system leaks by replacing components, add additional amounts of oil as specified:

Evaporator	3 oz.
Condenser	1 oz.
Receiver-Dehydrator	1 oz.
Accumulator	1 oz.

NOTE – If oil drained contains metal chips or other foreign material, replace receiver-drier and flush or replace other components as necessary.

GENERAL MOTORS W/4 CYLINDER COMPRESSOR

The four cylinder compressor is charged with 5.5-6.5 ounces of refrigeration oil.

Components Rupture, Fast Discharge – Correct leak and flush system. Drain compressor and add 5.5 ounces of refrigerant oil to compressor crankcase through suction port.

Slow Leak – When loss of refrigerant has occurred over an extended period of time, add 3 ounces of refrigerant oil to system.

Oil Charge Doubtful – If oil charge, system performance, and efficiency are in doubt, it is recommended that system be flushed and the exact oil charge (5.5-6.5 ounces) be added to compressor prior to any further checks of system.

Component Replacement – When necessary to replace a component, it is recommended that oil be added to system as follows: If compressor is operable, idle vehicle for 10 minutes with A/C controls set for maximum cooling and high fan speed. Stop engine and discharge system. Add new refrigerant oil to components as indicated:

Condenser	1 oz.
Evaporator	3 oz.
Desiccant Bag	1 oz.
Compressor	Amount Drained

YORK & TECUMSEH COMPRESSORS

FORD MOTOR CO. W/SCHRADER SERVICE VALVES

Check compressor oil level only if any portion of refrigerant system is being replaced, or if system was discharged due to a leak.

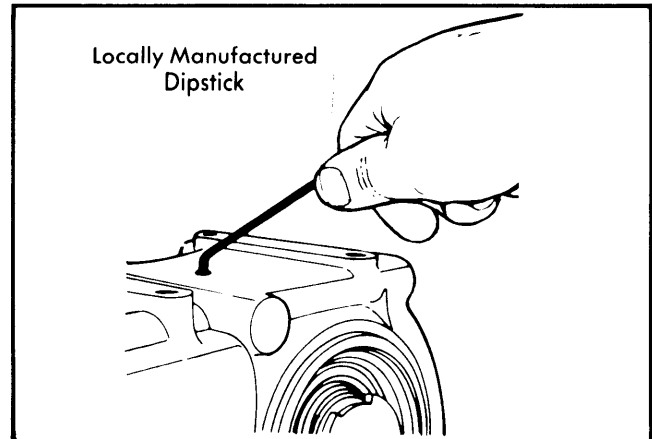

Fig. 2 Checking Compressor Oil Level Horizontally Mounted Unit

On horizontally mounted compressors, oil check hole is located on side of crankshaft which faces up. On opposite or downward side there is a corresponding boss provided on inner wall as an alternate oil check hole, for different mounting. When checking oil level on such a compressor, angle the dipstick such that it bottoms against lower side of compressor and not against boss.

1) After system has been charged, operate for approximately 10 minutes, or until pressures have stabilized (with ambient temperature of 60°F or higher).

2) Stop engine and discharge entire system using a suitable Schrader-Type service valve. Fabricate a suitable dipstick according to specifications (see Fig. 3). Remove oil filler plug and insert dipstick until it bottoms. If necessary, slightly rotate compressor crankshaft by hand so that dipstick will clear. Level on dipstick must be within specifications.

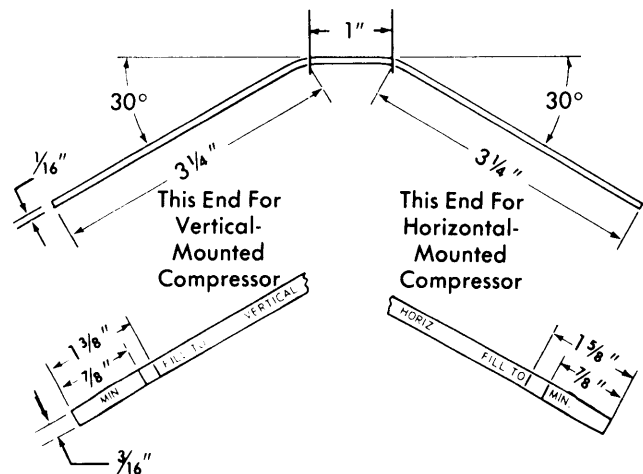

Fig. 3 Tecumseh Compressor Oil Level Dipstick

Air Conditioning Servicing

COMPRESSOR OIL CHECK (Cont.)

TECUMSEH COMPRESSOR OIL LEVEL	
Application	Dipstick
All Models	
Horizontal Mount	$\frac{7}{8}$ - $1\frac{5}{8}$ "
Vertical Mount	$\frac{7}{8}$ - $1\frac{3}{8}$ "

FORD MOTOR CO., JEEP & IHC W/STEM TYPE SERVICE VALVES

Oil level should be checked whenever the system is discharged for service part replacement, or if system has self-discharged due to component malfunction. Oil level is checked with compressor in its operating position.

It is important when checking oil level that system has been operated and car interior temperature has cooled to desired setting. This is necessary to stabilize amount of oil in the system.

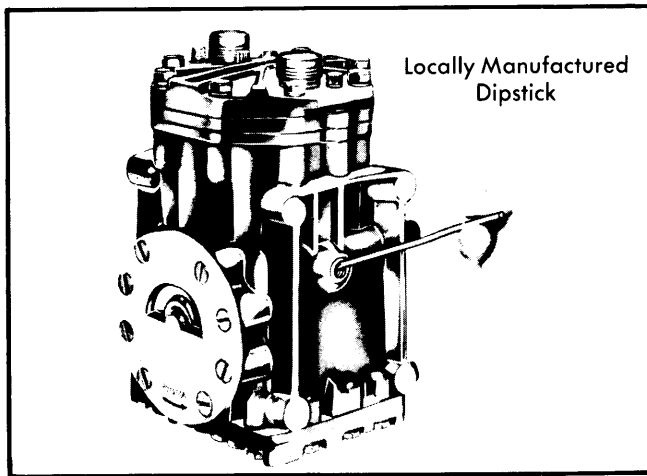

Fig. 4 Checking Oil Level On Vertically Mounted York Compressor

YORK COMPRESSOR OIL LEVEL	
Application	Dipstick Reading
All Models	
Horizontal Mount	$\frac{13}{16}$ - $1\frac{3}{16}$ "
Vertical Mount	$\frac{7}{8}$ - $1\frac{1}{8}$ "

NOTE - The following oil checking procedure details isolating the compressor prior to checking; however, it is possible to discharge the entire system and then check the oil level.

1) Turn both the high and low pressure service valve clockwise as far as possible (front-seat position). Loosen cap on the high pressure service valve and bleed residual pressure from compressor.

CAUTION - Only loosen cap a small amount and DO NOT remove cap until pressure is totally relieved.

NOTE - Oil level check plugs are located on either side of compressor crankcase; use check plug which is most convenient when checking oil level with compressor on car.

2) Fabricate a suitable dipstick according to specifications (see Fig. 5). Insert appropriate end of dipstick into compressor and check oil level. Level on dipstick must be within specifications. Add clean refrigerant oil if necessary. Install a new "O" ring seal on filler plug.

3) When oil check is complete, compressor must be purged of air before operating the system.

NOTE - See procedure as outlined in Compressor Replacement in COMPONENT REPLACEMENT Section.

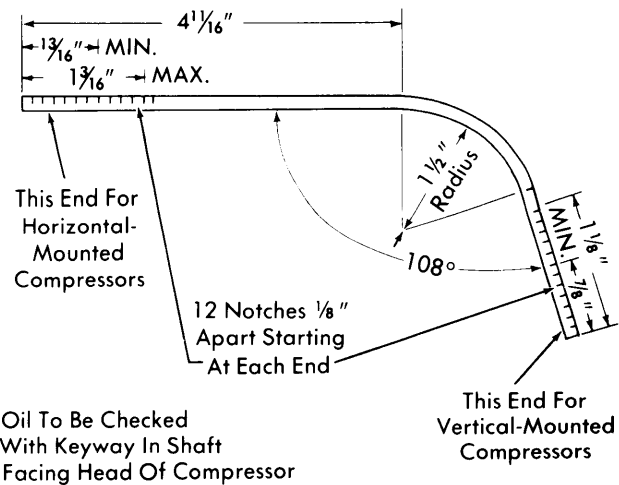

Fig. 5 York Compressor Oil Level Dipstick