

## GENERAL SERVICING

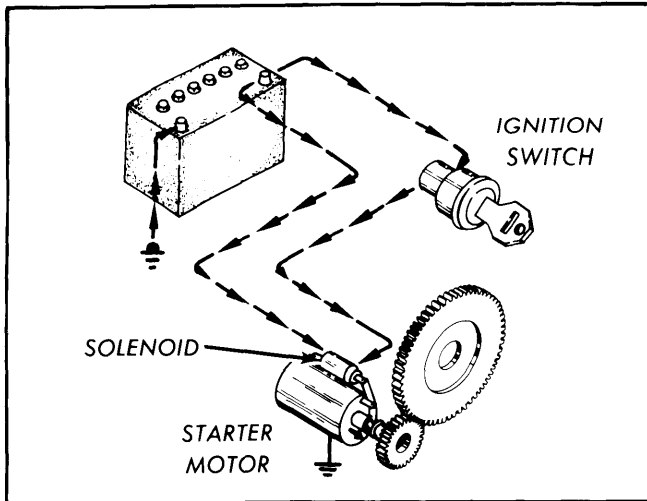

STARTING CIRCUIT IN OPERATION

## DESCRIPTION & THEORY OF OPERATION

### Starters

The Starter is an electro-mechanical device used to change electrical energy from the battery into mechanical energy to crank the engine. When the ignition switch is turned to the start position, voltage and current are applied to a solenoid or starter relay. The solenoid action then engages the starter drive (pinion) gear with flywheel gear and closes a large pair of switch contacts to supply voltage and current to the starter motor.

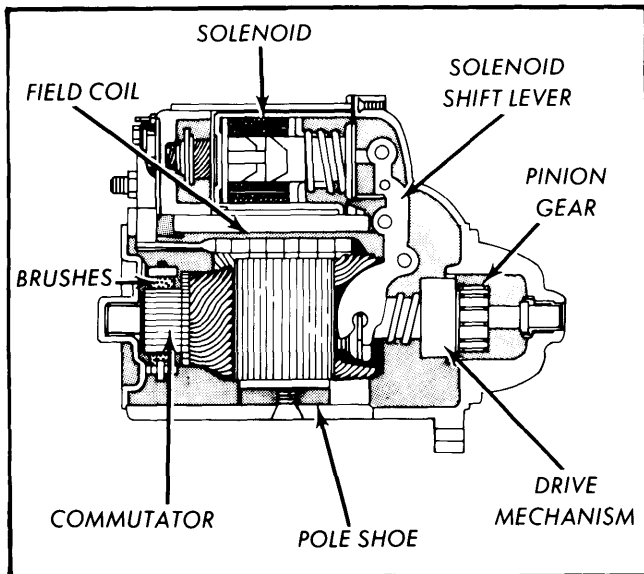

BASIC STARTING MOTOR

Basically the starter motor is a series wound direct current (DC) motor. The starter motor has very high horsepower for its size and is designed to operate for short periods of time under great overload. The basic starting motor has a Solenoid, Field Coils, Pole Shoes, Brushes, Commutator, Armature and a Drive Mechanism.

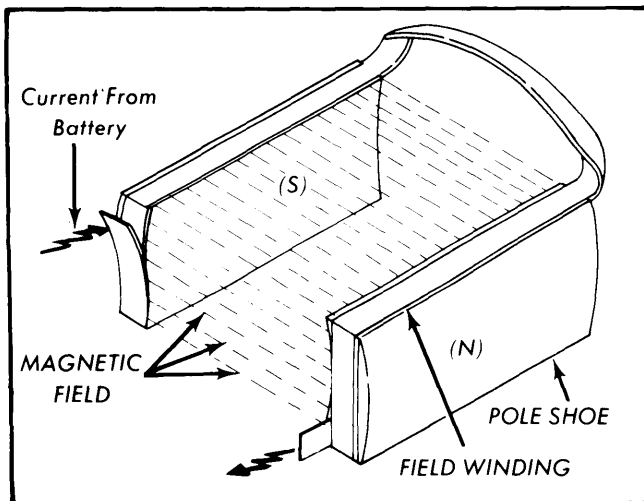

FIELD WINDING & POLE SHOES

To understand the basic electric motor you must remember that in magnetic fields **LIKE** magnetic poles repel and **UNLIKE** poles attract each other. That is to say two north (N) poles or two south (S) poles will repel each other and a north (N) pole and a south (S) pole will attract each other.

Think of the pole shoes in the field frame assembly as opposite ends of a magnet (N & S). The space between these poles is called the magnetic field. If a wire, called a Field Winding, is wrapped around these pole shoes and electric current is passed through it, the strength of the magnetic field between the pole shoes is increased.

# Starters

## GENERAL SERVICING (Cont.)

### DESCRIPTION & THEORY OF OPERATION (Cont.)

Now take a loop of wire and feed electrical energy from the battery into the loop, a magnetic field is also formed around the wire as current flows through it. This loop will also have a north (N) and a south (S) pole as did the field windings.

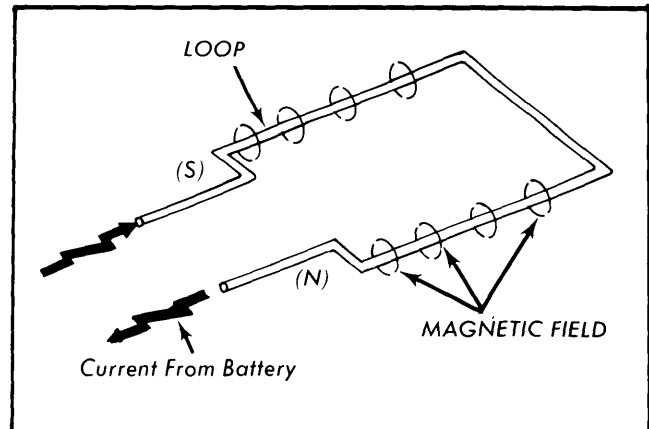

WIRE LOOP WITH MAGNETIC FIELD

When we place the loop of wire in the magnetic field between the pole shoes and pass current through the loop, we have a simple Armature. The magnetic field around the loop and the field between the pole shoes repel each other, causing the loop to turn.

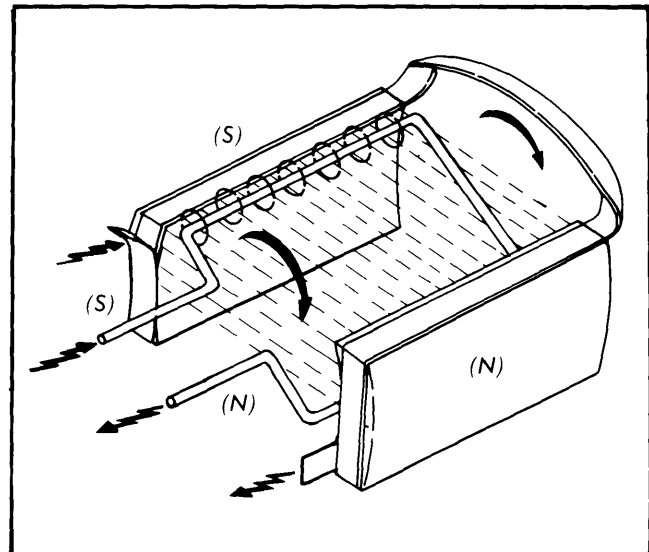

WIRE LOOP IN MAGNETIC FIELD

In an actual armature there are more loops which are connected to separate pieces of copper metal which form a contact surface called a Commutator. Electrical power is supplied to the commutator by sliding contacts called Brushes.

When power is applied to a loop through the brushes and commutator, the loop is repelled from the pole shoe which is next to it. As the loop and commutator rotate away from the pole shoe, a point is reached where the commutator no longer contacts the brushes. At this point no current is flowing through the loop and the loop magnetic field collapses.

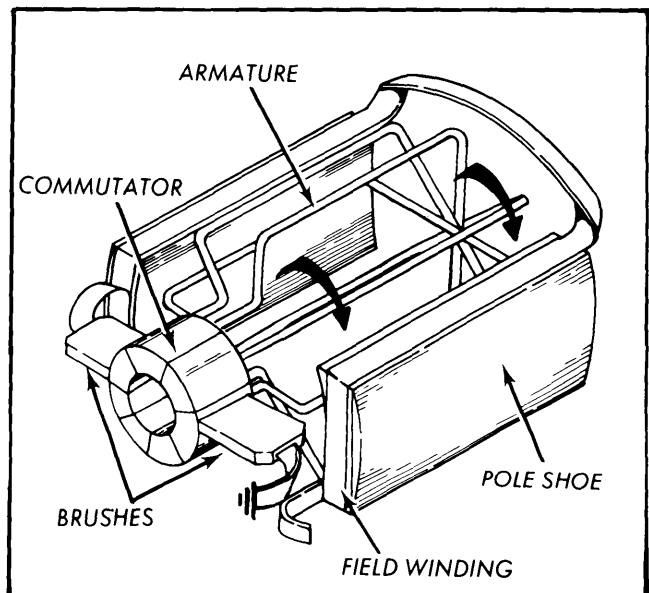

BASIC DC ELECTRIC MOTOR

At this time there is no more repelling action between the pole shoes and armature loop. When the first loop's commutator segments lost contact with the brushes, the second set of segments make contact with the brushes and the second loop is repelled by the pole shoes. In this manner continuous rotation is achieved by the loops of the armature.

## GENERAL SERVICING (Cont.)

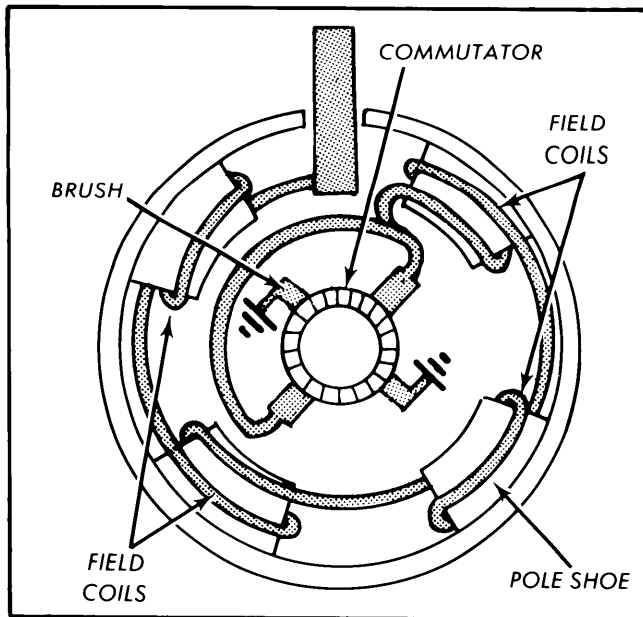

FOUR-POLE/FOUR-COIL SERIES WOUND MOTOR (TYPICAL)

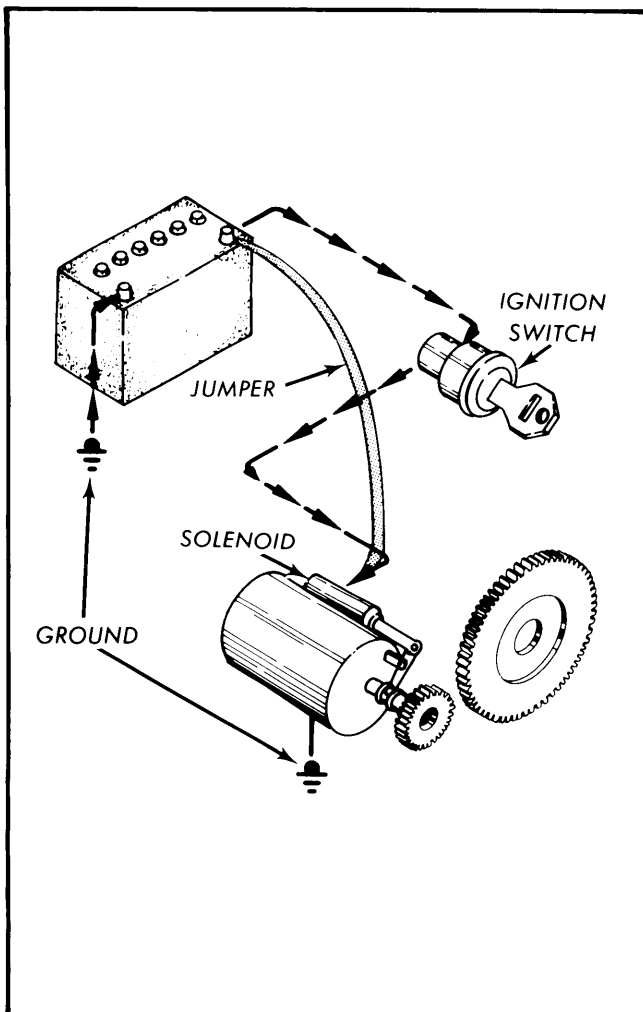

NO-START CONDITION TEST

## DESCRIPTION & THEORY OF OPERATION (Cont.)

Starter motors may have two, four or six brushes with a like number of field windings. As more loops are added to the armature the power of the motor is increased. Also, as the number of pole shoes and field windings plus number of ampere turns on each pole is increased, the power of the starter motor will increase.

## TESTING

### Starters

**CAUTION** – Before making any starter tests, place transmission in Park or Neutral and apply parking brake to avoid injury if vehicle were to move.

**NOTE** – Many starters require 10½ volts at the starter terminals to crank properly. Before any starter tests are made, check battery and battery cables. Battery must be fully charged with no shorted or dead cells. If battery cannot provide the correct voltage it must be recharged or replaced. Battery cables must be correct gauge and connections must be clean and tight. Always replace cables when necessary with the exact length and diameter cable. Installing a longer or smaller diameter cable increases the resistance permitting less voltage to be delivered to the starter. Replacement cable should be same length and preferably No. 4 gauge.

When the starting switch is closed, you can expect one of five things to occur if the starting circuit is defective:

### 1. STARTER SWITCH CLOSED AND NOTHING HAPPENS

This indicates that current is not reaching the solenoid and switch contacts are not closing to complete circuit. The problem lies in part of the circuit leading up to the solenoid, in the solenoid or starter relay.

To check this condition, connect a jumper lead directly between positive battery terminal and ignition switch terminal of solenoid or starter relay. If engine cranks, the circuit is open somewhere between battery and solenoid. If solenoid switch does not close, solenoid or starter relay is defective and must be replaced (See TESTING – Solenoids, described later in this story).

# Starters

## GENERAL SERVICING (Cont.)

### TESTING (Cont.)

#### 2. SOLENOID CONTACTS "CLICKED" BUT STARTER MOTOR DID NOT OPERATE

This indicates problem is within starter motor. If solenoid switch contacts close and switch begins to chatter, there is low voltage at the starter because of low battery charge, or high resistance in circuit, or an open in the hold-in winding of the solenoid. If battery charge is good, clean and inspect battery cable to solenoid connections. If solenoid and cable connections are good, problem is in starter motor and it must be replaced.

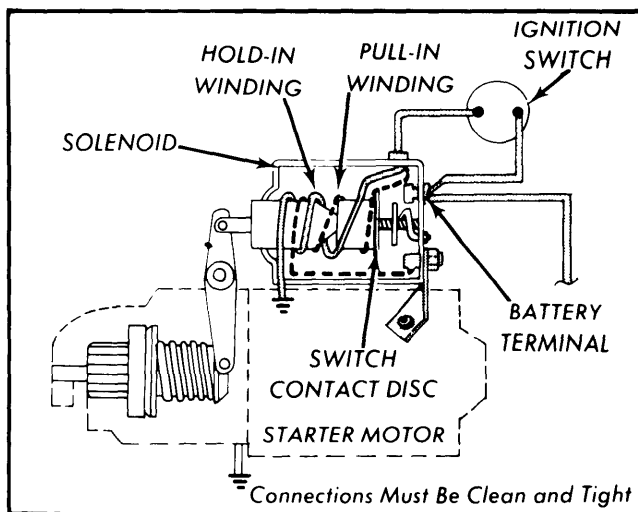

SOLENOID WIRING CIRCUIT

#### 3. STARTER MOTOR RAN BUT DID NOT TURN OVER ENGINE

Problem is either in the shifting of the drive assembly into mesh, a broken armature shaft, or a dirty or faulty drive assembly. All of these require starter replacement.

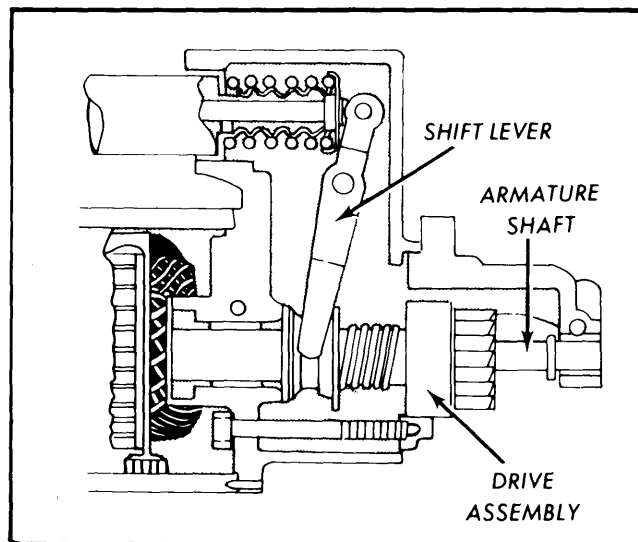

ARMATURE SHAFT & DRIVE ASSEMBLY

#### 4. STARTER MOTOR TURNED ENGINE OVER SLOWLY OR ERRATICALLY

Problem may be in starter motor or drive assembly. Before removing the starter motor, a voltage drop test should be made. A voltage drop test will locate any high resistance connections, shorted or grounded windings which would affect the starter motor.

With the engine cranking, connect a voltmeter between battery positive post and starter motor terminal. Voltage drop should be approximately .3-.6 of a volt, not exceeding .6 of a volt. Then connect the voltmeter between battery ground post and starter frame, voltage drop should be approximately .1-.3 of a volt, not exceeding .3 of a volt. If no high resistance connections are found, inspect pinion drive and flywheel ring gear. If either gear is damaged, starter or flywheel ring gear must be replaced.

**NOTE** — For exact voltage drops, see manufacturer's test specifications.

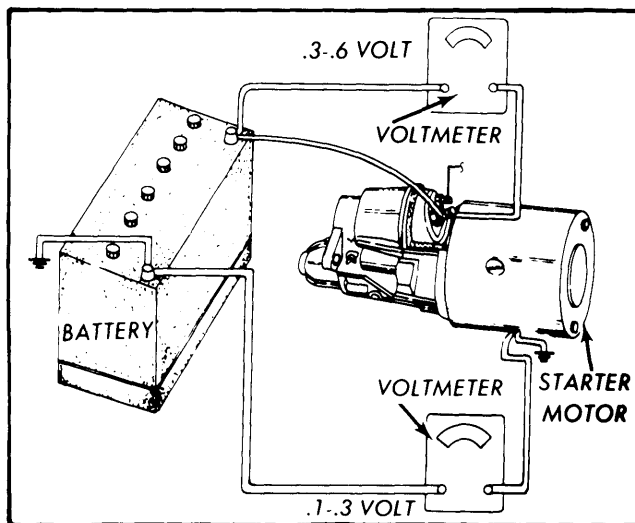

VOLTAGE-DROP TEST

## GENERAL SERVICING (Cont.)

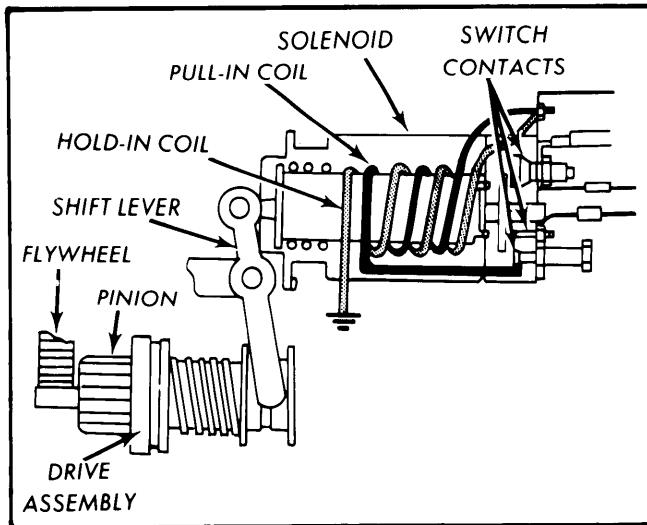

SOLENOID & DRIVE ASSEMBLY (DISENGAGED)

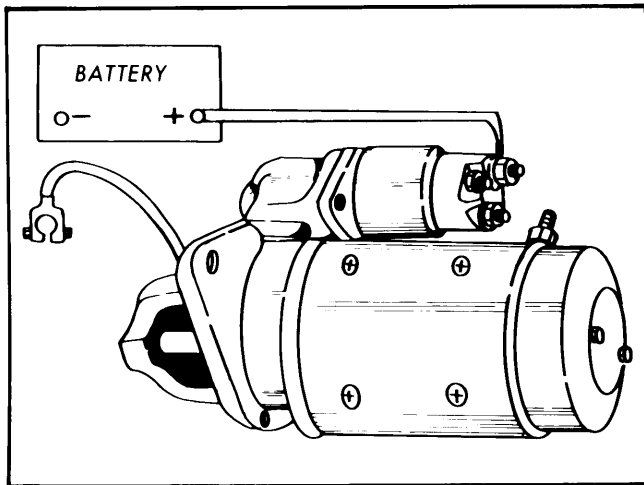

DISCONNECTING BATTERY CABLE FOR SAFETY

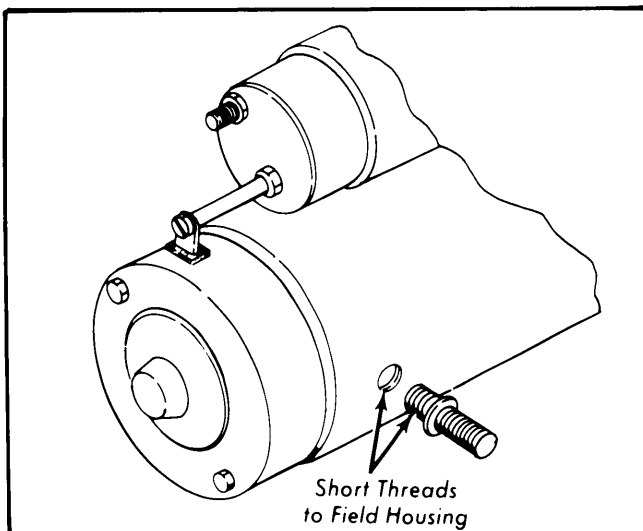

DELCO-REMY FIELD HOUSING BOLT INSTALLATION  
(LATE MODELS)

## TESTING (Cont.)

### 5. ENGINE STARTS BUT MOTOR DRIVE ASSEMBLY DOES NOT DISENGAGE

This indicates a faulty drive assembly, solenoid pull-in windings, solenoid contacts, broken return spring, GM shims left out or solenoid control circuit which will not let drive assembly retract and disengage the flywheel ring gear. If the solenoid is at fault, (See TESTING — Solenoids, described later in this story).

## INSTALLATION

### Starters

**CAUTION** — Always disconnect battery ground cable at the battery before connecting or disconnecting any wire or cable at the starter or solenoid. This will prevent shorts, arcing or accidental starter engagement.

**NOTE** — On certain late model Delco-Remy starters a special bolt is used in the field housing. This bolt is packaged with some rebuilt starters. Make certain that the short end with the coarser threads goes into the field case. If the longer end is installed in the field case damage to the field coil may result.

**NOTE** — Whenever you remove a nut from the solenoid, disconnect the cable and then replace nut back on the stud. This will prevent thread damage caused by running the wrong nut onto the stud.

## GENERAL SERVICING (Cont.)

## INSTALLATION (Cont.)

**NOTE** — General Motors Corp. vehicles may require starter shims to provide correct starter pinion gear-to-flywheel engagement. These shims are located between the starter drive housing and the engine block. If the original starter was installed with a shim or shims, then replacement starter may also require shim(s).

If replacement starter is installed to an engine which did not have shims and starter drive assembly does not engage properly or engine sounds tight: Disconnect battery cable to starter and turn ignition switch to "START" position. Visually check drive assembly engagement (the flywheel cover may have to be removed). Add shims until the correct engagement is made. Extra shims should be on hand.

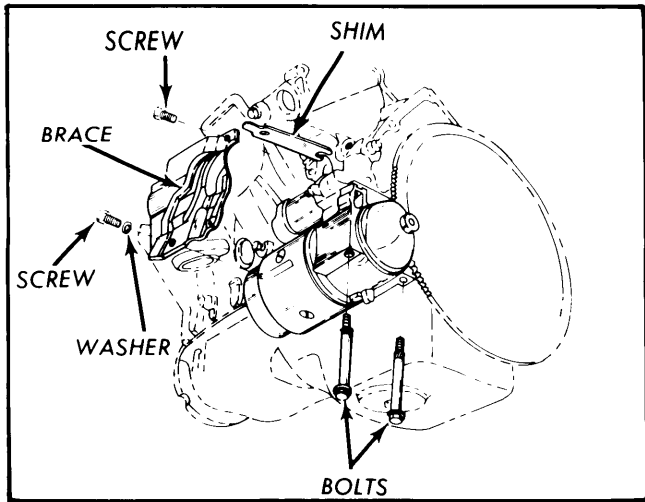

STARTER SHIM INSTALLATION (TYPICAL)

1. **REMOVAL** — Place transmission in park or neutral and apply parking brake. Disconnect battery ground cable at battery. Mark starter wires and battery cable for reassembly and disconnect from starter.

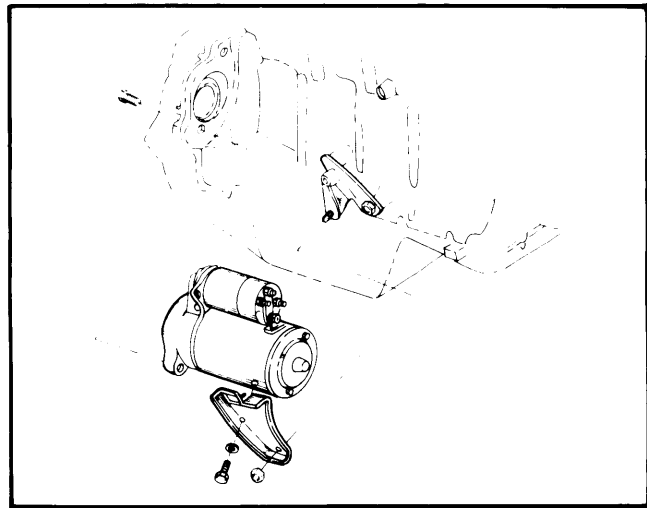

STARTER INSTALLATION 4-CYL. (TYPICAL)

2. Unbolt any mounting brackets or shields. **NOTE** — On some vehicles it may be necessary to remove the exhaust pipes to remove the starter. It may also be necessary to remove flywheel cover to reach all starter bolts.

3. Support starter and remove mounting bolts. Rotate or lower starter until clear of engine and remove from vehicle. Save any mounting shims for installation of replacement starter.

**NOTE** — Many Chrysler starter drives are damaged because of distributor "cross-fire" to more than one spark plug. The slowdown or sudden reversal of engine rotation while the drive is engaged can damage the drive or even break the drive end casting. If the old unit's starter drive is damaged, it is recommended that the distributor cap be checked inside and out for evidence of dirt, moisture or carbon tracking. Clean distributor cap or replace if necessary.

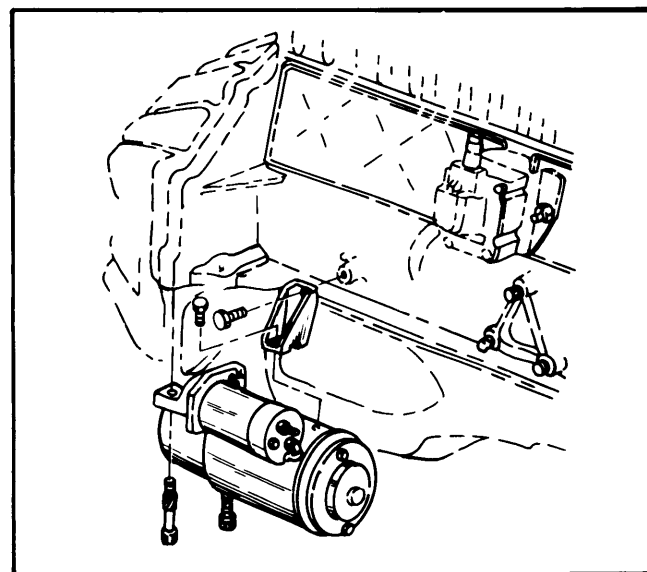

STARTER INSTALLATION 6-CYL. (TYPICAL)

## GENERAL SERVICING (Cont.)

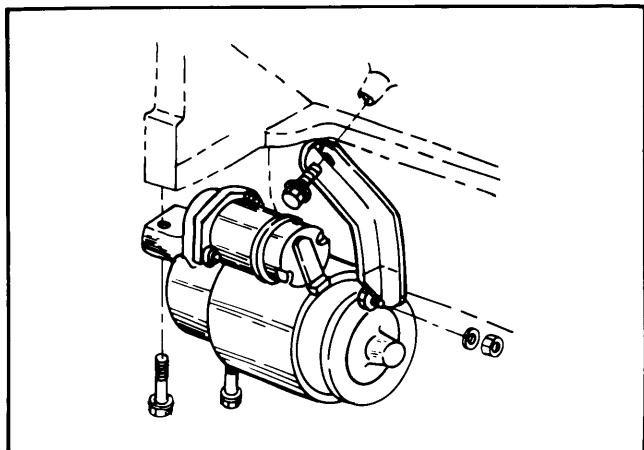

STARTER INSTALLATION V8 (TYPICAL)

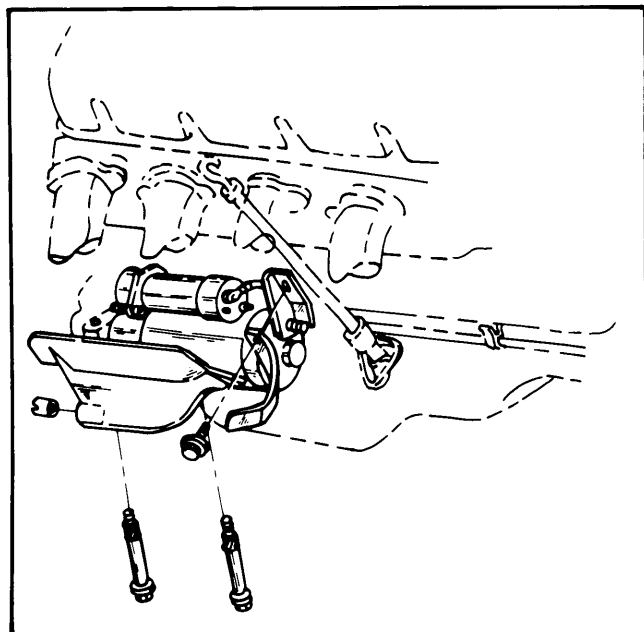

STARTER & HEAT SHIELD INSTALLATION (TYPICAL)

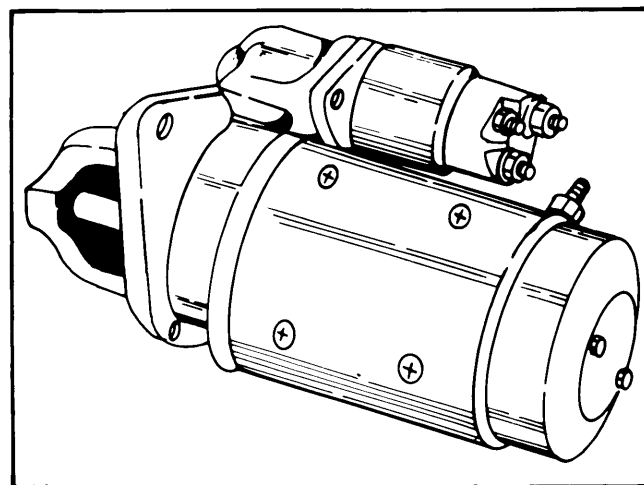

STARTER MOTOR (TYPICAL)

## INSTALLATION (Cont.)

1. **INSTALLATION** — Place starter and shims (if required) in mounting position. Install bolts finger tight. Attach mounting brackets and shields (if equipped) with bolts finger tight. Check that starter is correctly contacting engine. Tighten starter mounting bolts and then bracket and shield bolts.

**NOTE** — When mounting a Ford starter:

1. Install top bolt enough to hold starter in place.
2. Install and tighten bottom bolt.
3. If starter is a three hole mount, install and tighten center bolt first.
4. Tighten top bolt

This will level starter so the bendix will engage the flywheel properly. A cocked starter will cause the bendix gear to bind against the flywheel.

2. Remove nuts one at a time and connect all wires and leads to starter. Reconnect battery cable to the battery and check starter engagement and cranking. **NOTE** — Battery must be fully charged and cable connections clean and tight or poor starter cranking action may result.

## IDENTIFICATION

### Starters

Starters are broken down into manufacturer and type; Direct Drive-Solenoid Actuated, Reduction Gear-Solenoid Actuated, and Positive Engagement-Starter Relay Actuated. Ford Motor Co. and Jeep Corp. vehicles use both Direct Drive-Solenoid Actuated and Positive Engagement-Relay Actuated starter motors. General Motors Corp. and International Harvester Corp. vehicles use Direct Drive-Solenoid Actuated starter motors. Chrysler Corp. vehicles use both Reduction Gear-Solenoid Actuated and Direct Drive-Solenoid Actuated starter motors.

# Starters

## GENERAL SERVICING (Cont.)

### IDENTIFICATION (Cont.)

#### DELCO-REMY

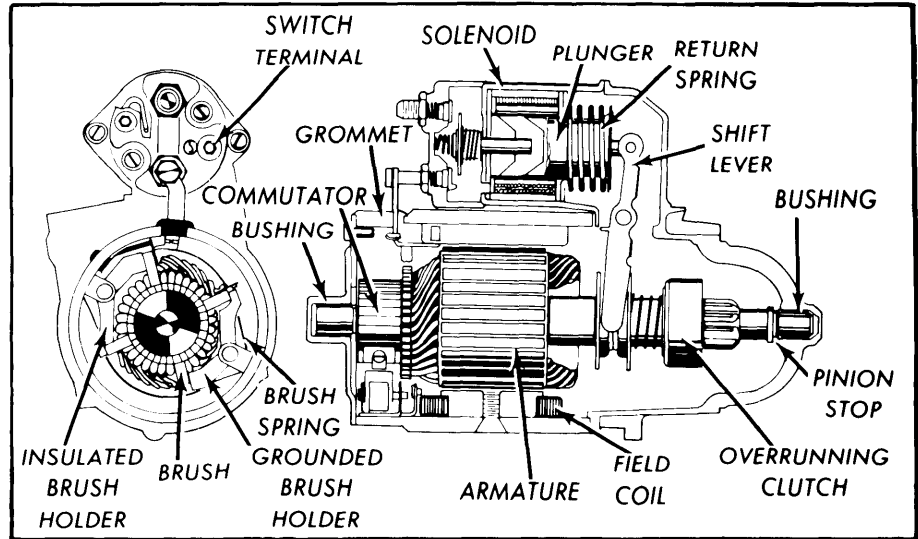

DELCO-REMY DIRECT DRIVE

#### CHRYSLER CORP.

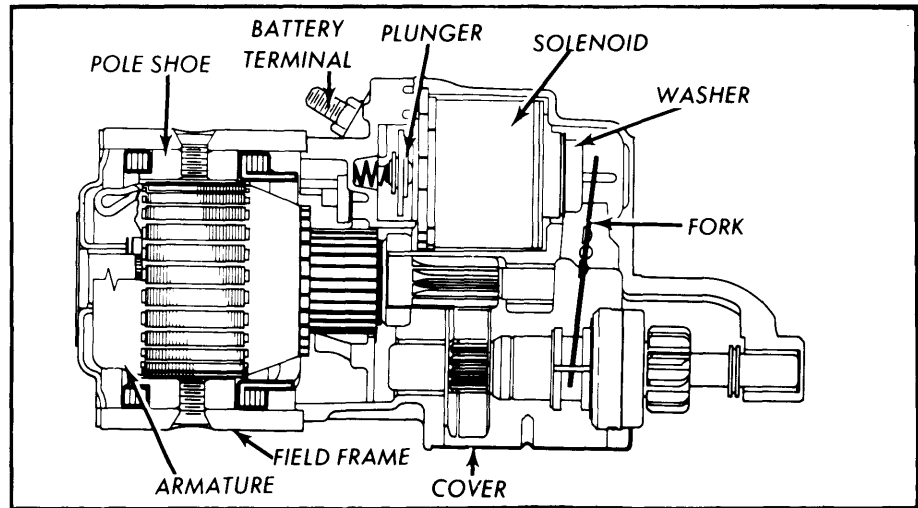

CHRYSLER CORP. REDUCTION GEAR DRIVE

#### CHRYSLER CORP.

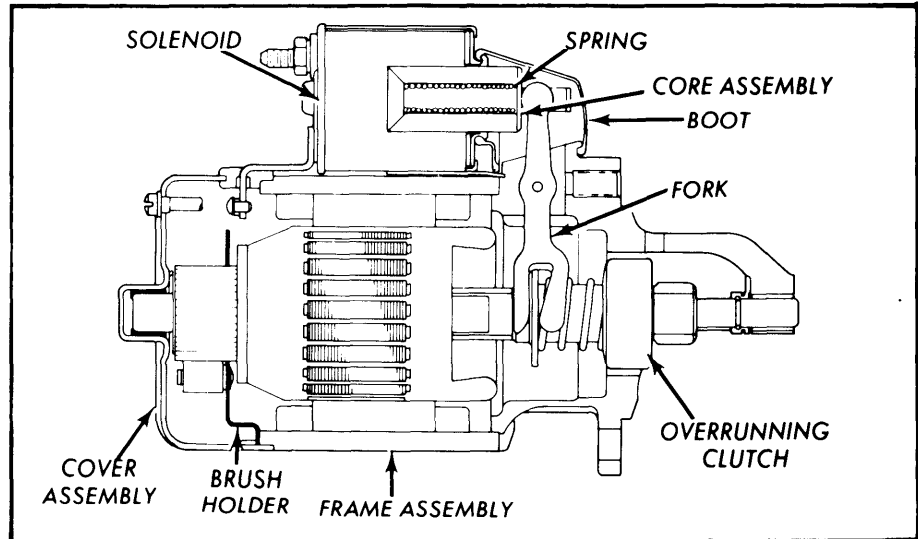

CHRYSLER CORP. DIRECT DRIVE

## GENERAL SERVICING (Cont.)

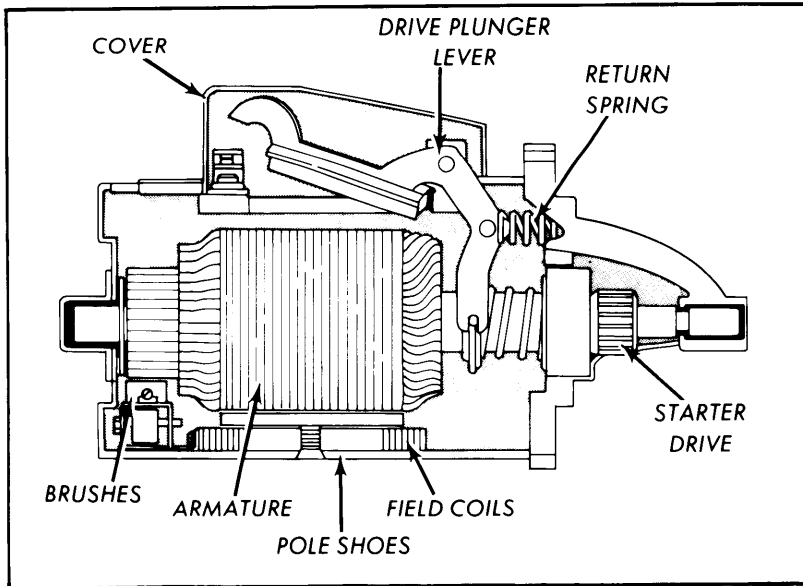

MOTORCRAFT POSITIVE ENGAGEMENT DRIVE

## IDENTIFICATION (Cont.)

FORD MOTOR CO.  
& JEEP CORP.

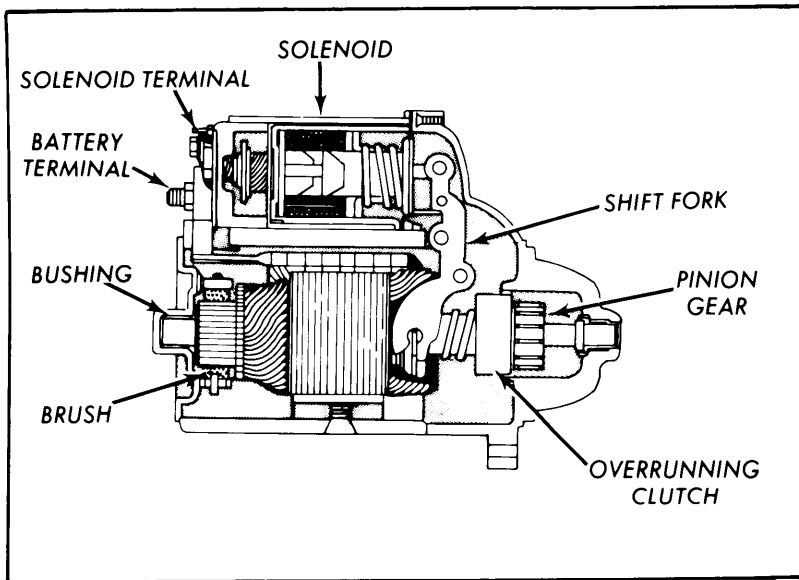

MOTORCRAFT SOLENOID ENGAGEMENT DRIVE

FORD MOTOR CO.  
& JEEP CORP.

# Starters

## GENERAL SERVICING (Cont.)

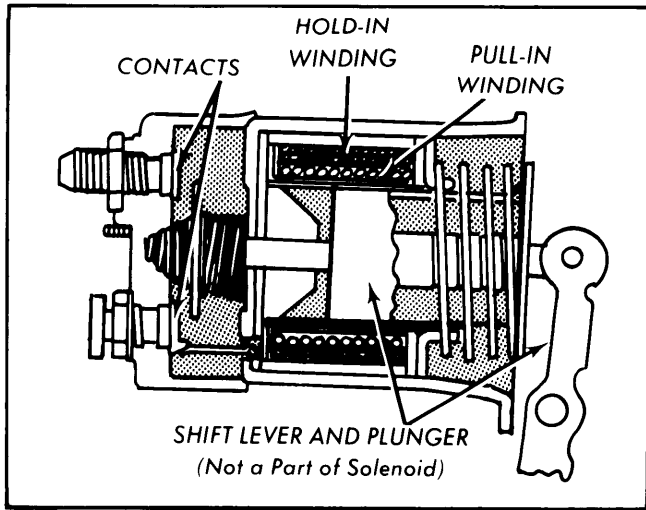

SOLENOID ASSEMBLY

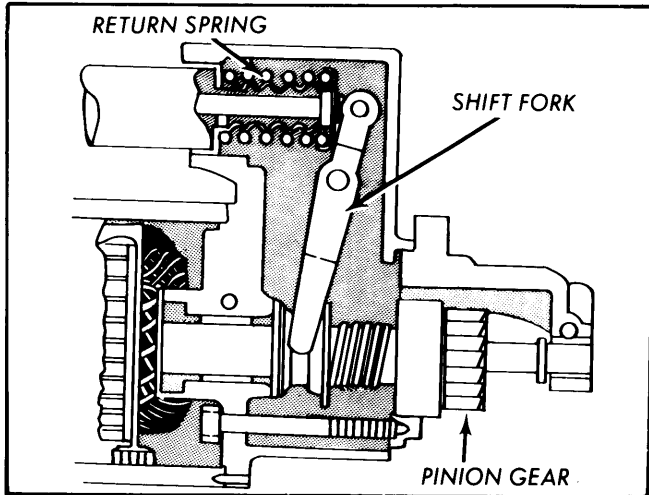

STARTER DRIVE ASSEMBLY

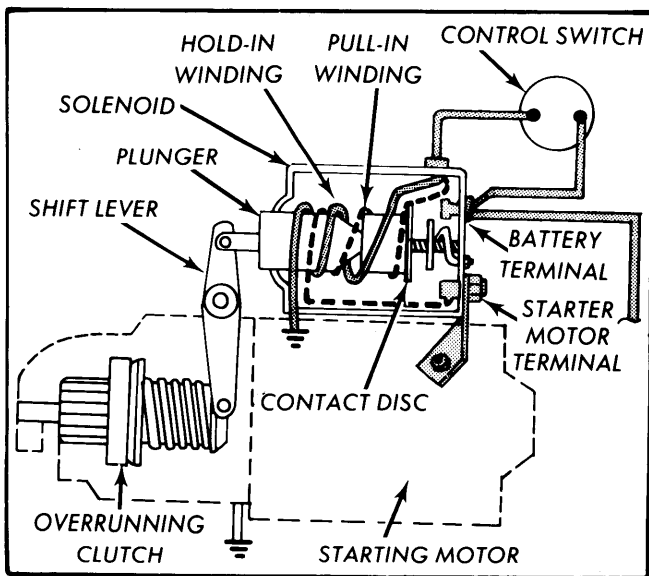

SOLENOID WITH COIL WINDINGS (DISENGAGED)

## DESCRIPTION & THEORY OF OPERATION

### Solenoids

The solenoid is an electrical switching device which is used to engage the starter drive assembly with flywheel ring gear and turn on the starter motor. It is mounted on the starter motor frame. A shift fork or lever is connected to the solenoid plunger on one end and to the starter drive assembly on the other end.

When voltage from the battery is applied to the two solenoid (Pull-In & Hold-In) windings, a strong magnetic field is set up and the solenoid plunger is drawn into the solenoid. This engages the drive assembly (overrunning clutch & pinion gear) with the flywheel ring gear and closes two large switch contacts to supply voltage and current to the starter motor.

The Pull-In winding is made up of heavy gauge wire with one end connected to ignition switch terminal and the other end connected to the large starter motor terminal of the solenoid. It gets its ground through the starter motor wiring.

The Hold-In winding is made up of an equal number of turns of fine wire with one end also connected to the ignition switch terminal and the other end directly to ground.

When voltage from the ignition switch is applied to the solenoid terminal, both windings are engaged and the solenoid plunger is drawn into the solenoid by a large magnetic field. When the solenoid plunger closes the battery-to-starter motor terminals, the winding of the pull-in coil is shorted and only the hold-in winding is in operation. Current flow through the solenoid windings is thereby reduced.

## GENERAL SERVICING (Cont.)

### DESCRIPTION & THEORY OF OPERATION (Cont.)

The hold-in winding holds the drive assembly engaged and keeps the starter motor running. When the ignition switch is released, voltage and current to ignition switch terminal is removed. Momentarily the hold-in and pull-in windings are connected in series and are powered from the starter motor terminal.

When the windings are connected in series the current flow in the pull-in windings is reversed. Because the current flow is equal in both windings, the magnetic field of one coil opposes that of the other, causing an immediate collapse of the magnetic field. The return spring quickly moves the plunger back to its original position and opens the battery-to-starter motor terminals and disengages the starter drive assembly.

### TESTING

#### Solenoids

1. Disconnect all leads going to the solenoid. Disconnect the solenoid-to-starter motor connection at the solenoid. Tape the starter motor lead to the starter housing to prevent accidental motor engagement.

2. Connect a lead with a switch in it (remote starter switch) between the battery positive post and the ignition switch terminal (marked "S") of the solenoid. Connect the battery negative cable to the starter motor frame or solenoid body (ground).

3. Close the switch and **Momentarily** jumper the starter motor terminal of the solenoid to the starter motor frame (ground). The solenoid should engage and remain engaged. If the solenoid did not engage, the pull-in winding is defective.

**NOTE** — Do not leave the switch closed for long periods of time to prevent the solenoid windings from overheating.

4. Close the switch, but **Do Not** use the jumper. Manually pull out the starter drive assembly. The drive assembly should remain engaged until switch is opened at which time it should return without hesitation. If drive assembly does not remain engaged, hold-in winding is defective. If drive assembly does not return without hesitation, return spring is defective.

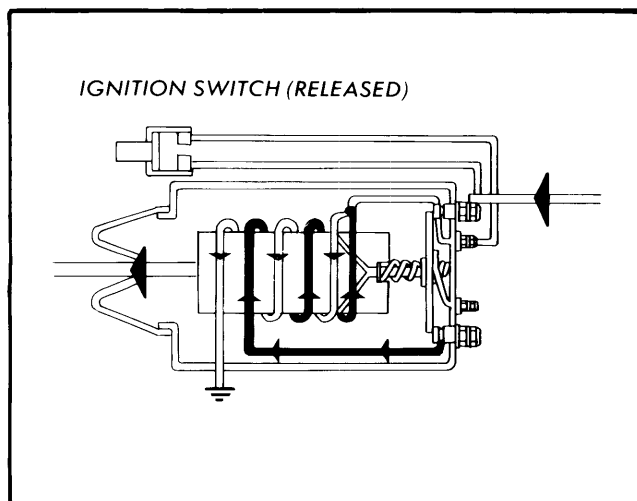

SOLENOID WITH COIL WINDINGS (ENGAGED)

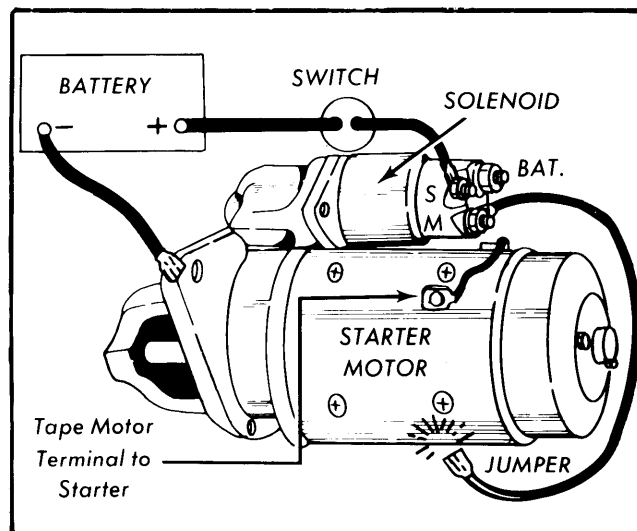

SOLENOID PULL-IN WINDING TEST

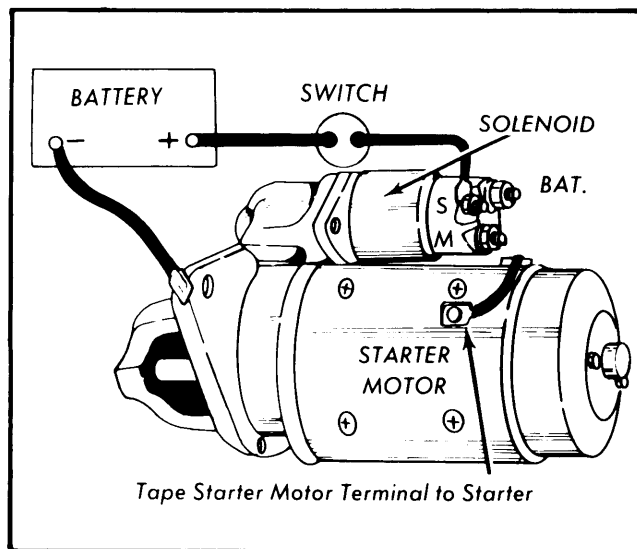

SOLENOID HOLD-IN WINDING TEST

## GENERAL SERVICING (Cont.)

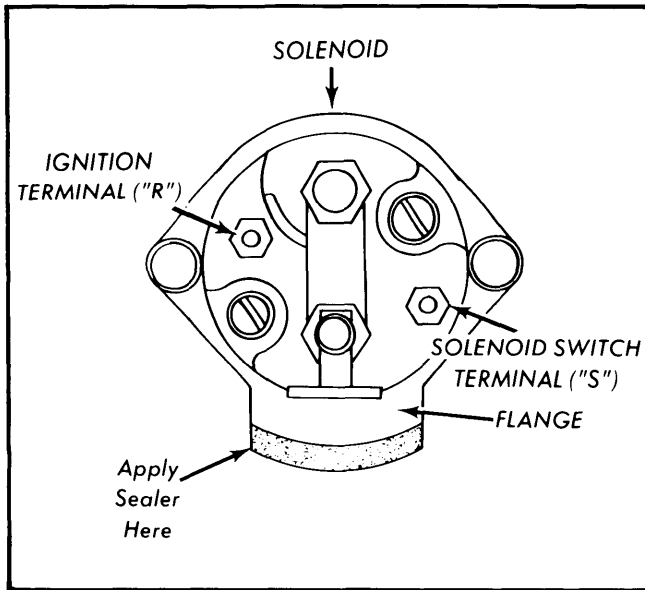

SOLENOID SEALER APPLICATION

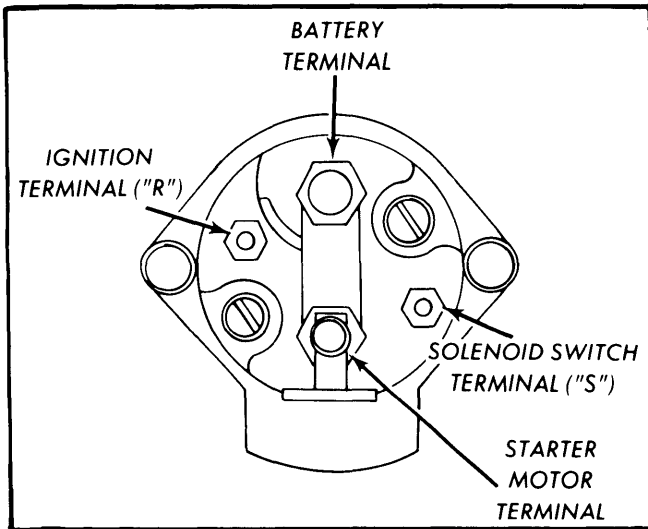

SOLENOID TERMINAL IDENTIFICATION

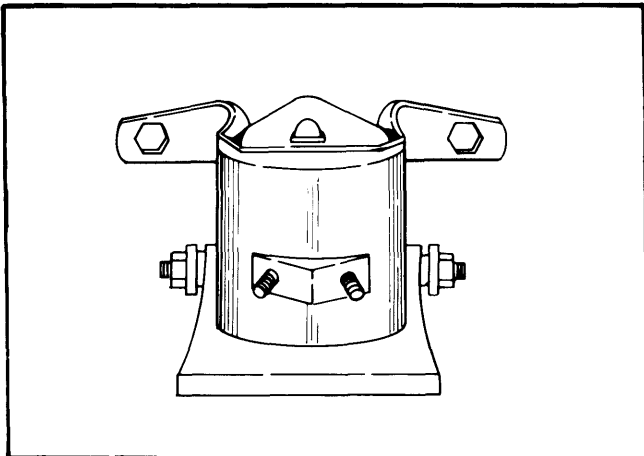

STARTER RELAY (TYPICAL)

## INSTALLATION

## Solenoids

The following procedure is a typical Delco-Remy installation:

Coat solenoid flange with sealer to prevent dirt, moisture, etc. from the road from entering the starter. Slide solenoid over plunger until it contacts mounting boss. Rotate solenoid until flange slides into slot in motor frame. Install and tighten mounting screws.

## IDENTIFICATION

## Solenoids

There are generally four electrical terminals located on the back of the solenoid. The two larger terminals are the battery terminal (upper) and starter motor terminal (lower). The two smaller terminals are ignition switch terminal (marked "S") and ignition coil terminal (marked "R"). **NOTE** — Not all solenoids have an ignition coil terminal. For example; late model vehicles with high energy ignition systems do not use ignition coil terminal (marked "R").

**NOTE** — On Motorcraft Positive engagement starters there is no solenoid mounted on the starter motor, instead there is a starter motor relay usually mounted on the fender well next to the battery. A starter relay is used because of high current requirements. The relay is located so that the heavy connecting cables are short and will conduct heavy current flow with a minimum of voltage loss (drop).