

DELCO-REMY WITH INTEGRAL REGULATOR

Chevrolet
GMC
International Harvester
Jeep

NOTE — Jeep models with V8 engines use a Motorcraft alternator. See Motorcraft With Separate Regulator Alternators in this section.

DESCRIPTION

Both the Delcotron 10 SI and 27 SI integral alternator regulators feature a solid state regulator mounted inside the alternator. The 10 SI model is available with different outputs at idle and different maximum outputs. The 27 SI model puts out 50 amps at idle with an 80 amp continuous output. The construction and operation of both models is the same. Delcotrons consist primarily of two end frame assemblies, rotor, stator, brushes, slip rings, and diodes. Rotor is supported in drive end frame by ball bearings and in slip ring end frame by roller bearings. Bearings contain enough lubricant to eliminate the need for periodic lubrication.

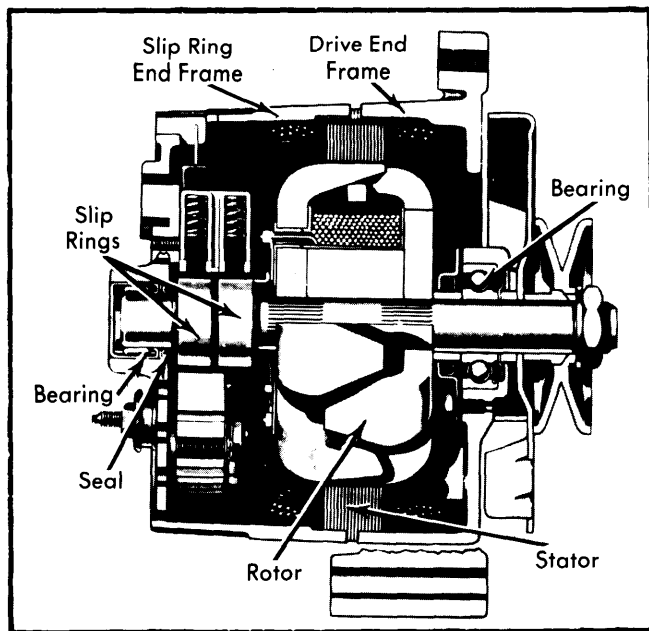

Fig. 1 Cross Sectional View Showing Internal Components of Delcotron Integral Alternator/Regulator

OPERATION

Two brushes carry current through the slip rings to the field coil mounted on the rotor. The stator windings are assembled on the inside of a laminated core that forms part of the alternator frame. A rectifier bridge connected to the stator windings contains 6 diodes (three positive and three negative) molded into an assembly. This rectifier bridge changes stator a.c. voltage into d.c. voltage which appears at output terminal. The blocking action of the diodes prevents battery discharge back through the alternator. Because of this blocking action the need for a cutout relay is eliminated. Generator field current is supplied through a diode trio which is also connected to the stator windings. A capacitor is mounted in the end frame and protects rectifier bridge and diodes from high voltages.

ADJUSTMENTS

No periodic adjustments or maintenance of any kind is required on entire generator assembly. Regulator voltage is preset and no adjustment facility is provided.

CAUTION — Do not attempt to polarize alternator. Do not short or ground any terminals except as instructed. Never operate alternator with battery out of circuit or output terminal open. Alternator and battery must share same ground polarity.

TESTING

NOTE — Before making electrical checks, visually inspect all terminals for clean and tight connections. Check alternator mounting bolts and drive belt tension. Do not ground No. 2 lead wire. Battery must be in good condition to test charging system.

UNDERCHARGED BATTERY

1) With ignition switch ON connect a voltmeter from alternator "BAT" terminal to ground, then from No.1 terminal to ground, (see illustration) and No. 2 terminal to ground. A zero reading indicates an open between connection and battery. An open No. 2 lead will cause uncontrolled voltage. This may cause overcharge, and possible damage to accessories. Opens in this circuit may be between terminals at the crimp between harness wire and terminal, or in wire.

NOTE — If preceding test is satisfactory, continue to next step.

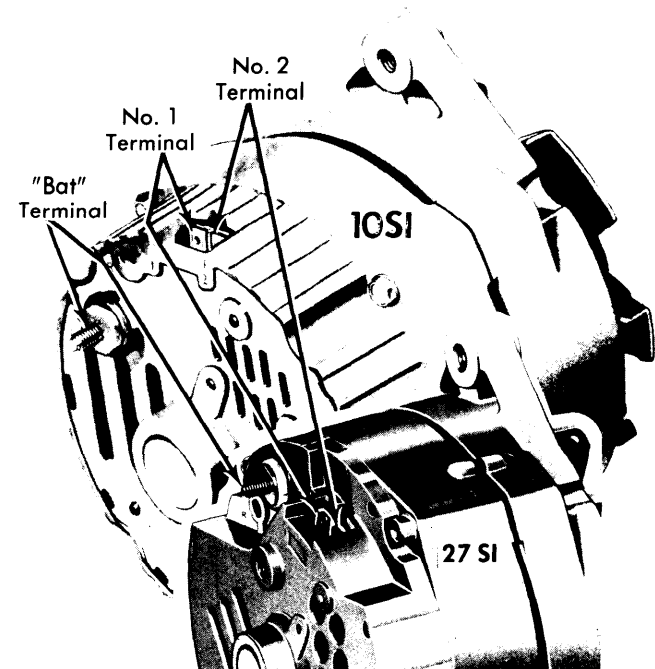

Fig. 2 Identification of Delcotron Terminal Locations

2) Disconnect battery ground cable. Connect an ammeter in the circuit at the "BAT" terminal of alternator. Reconnect battery ground cable. Turn on all available accessories. Connect a carbon pile across battery. Operate engine at moderate speed and adjust carbon pile as required to obtain maximum current output. If ampere output is within 10 amps of rated output as stamped on alternator case, alternator is

DELCO-REMY WITH INTEGRAL REGULATOR (Cont.)

good. If output is not within 10 amps of rated output, ground the field winding by inserting a screwdriver into test hole. See Fig. 3. **CAUTION**—Tab is within $\frac{3}{4}$ " of casting surface, do not force screwdriver deeper than one inch into end frame.

3) Operate engine at moderate speed as required and adjust carbon pile for maximum output. If output is now within 10 amps of rated output with fields grounded, regulator is defective and requires replacement. If output is still not within 10 amps of rated output, check field winding, diode trio, rectifier bridge, and stator. **NOTE**—If test hole is not accessible, perform "Tests (On Bench)" as described under OVERHAUL.

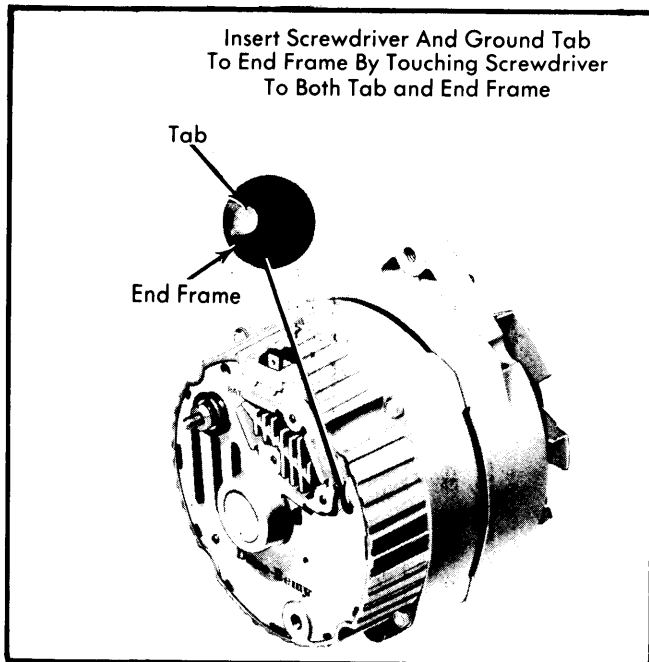

Fig. 3 View Showing Field Ground Tab Accessible Through Hole in End Frame

GENERATOR OUTPUT TEST

1) To bench check alternator proceed as follows: Make connections as shown in illustration, except leave carbon pile disconnected. Use a fully charged battery, and a 10 Ohm resistor rated at 6 watts or more between alternator No. 1 terminal and battery. Slowly increase alternator speed and observe voltage. If voltage is uncontrolled with speed and increases above 16 volts, check for a grounded brush lead clip. If brush lead clip is OK replace regulator.

2) Connect carbon pile. Operate alternator at moderate speed and adjust carbon pile to obtain maximum output. If output is within 10% of rated output as stamped on alternator frame, alternator is good. If not, ground generator field with a screwdriver. If output is now within 10% of rated output, regulator is defective.

OVERCHARGED BATTERY

Connect a voltmeter from alternator No. 2 terminal to ground. If reading is zero, No. 2 lead circuit is open. If No. 2 lead circuit checks out good, alternator will have to be disassembled for further checks (see OVERHAUL).

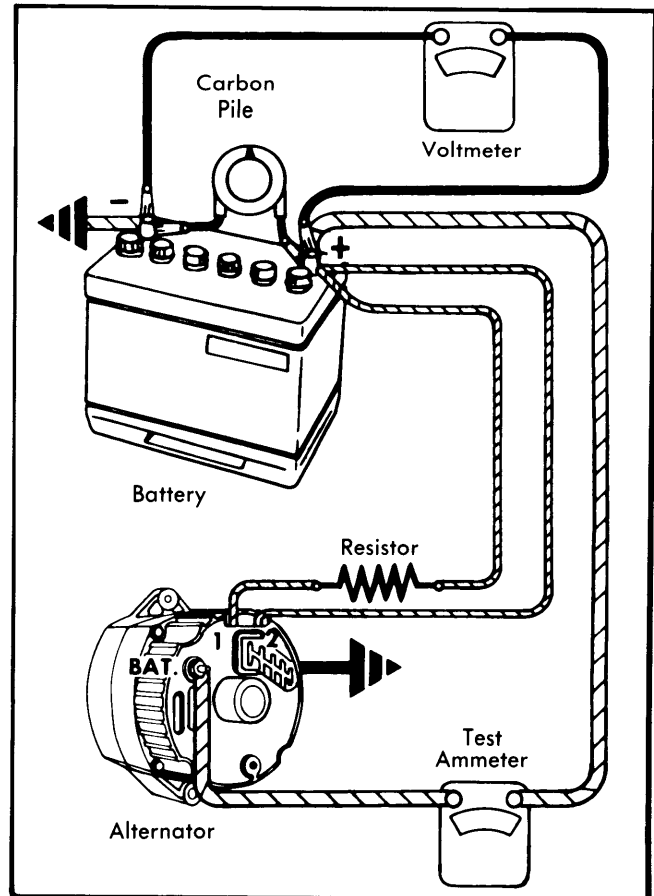

Fig. 4 Alternator Bench Test Connections

OVERHAUL

DISASSEMBLY

1) Hold alternator in a vise, clamping mounting flange lengthwise. Remove thru bolts and separate slip ring end frame and stator assembly from drive end and rotor assembly by prying apart with a screwdriver at stator slots.

2) Place a piece of tape over slip ring end frame bearing to prevent entry of dirt. At this point brushes may drop onto rotor shaft and become contaminated with bearing lubricant, clean brushes as soon as possible with a suitable cleaner (acetone) to keep them from becoming grease soaked.

3) Remove stator lead attaching nuts and separate stator from end frame. Remove screw attaching diode trio to brush holder and remove diode trio from end frame. Remove rectifier bridge attaching screw and "BAT" terminal screw, and disconnect capacitor lead. Remove rectifier bridge from end frame. Remove brush holder and regulator. Note that two insulators are assembled over top of brush retaining clips, and that the two screws have special insulating sleeves.

4) Remove capacitor from end frame. Remove slip ring end frame bearing if necessary. Remove pulley nut by holding shaft with an Allen wrench. Remove pulley. Remove rotor and spacers from drive end frame assembly. If necessary remove drive end frame bearing retainer plate, then gasket and bearing.

DELCO-REMY WITH INTEGRAL REGULATOR (Cont.)

INSPECTION

Wash all metal parts except bearings and stator, and rotor. Inspect rotor slip rings, they may be cleaned with 400 grain polishing cloth. Slip rings may be lathe turned to a .001" indicator reading. Slip rings are not replaceable, excessive damage will require rotor replacement. Inspect brushes for wear, if they are worn halfway replace them.

TESTING (ON BENCH)

Rotor Field Winding — Check rotor for grounds or an open circuit with a 110 volt test lamp or ohmmeter (see illustration). Test for grounds between slip ring and rotor shaft; no continuity should exist. Test for an open field by connecting test leads across slip rings, continuity should be obtained. Test for shorts by connecting a 12 volt battery and ammeter in series with both slip rings, or an ohmmeter may be used. Current draw should be 4-4.5 amps., or resistance should be about 2.5-3.0 ohms. Excessive amperage draw or low resistance indicates shorted windings. If rotor tests okay, but alternator output is low, continue with tests.

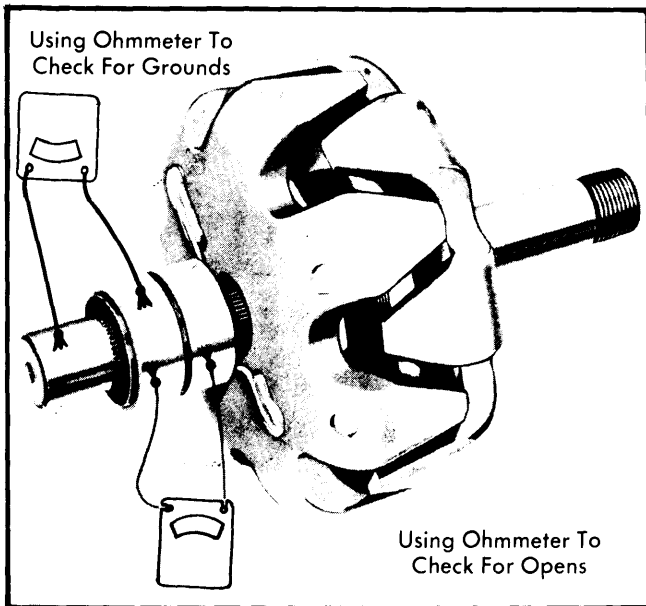

Fig. 5 Bench Testing Rotor For Opens or Grounds Using an Ohmmeter

Stator Checks For Grounds — Connect a 110 volt test lamp or an Ohmmeter from any stator lead to stator frame. If test lamp lights or if resistance is low, windings are grounded.

Stator Checks For Opens — Connect a 110 volt test lamp or an Ohmmeter from any stator lead to stator frame. If test lamp does not light or if resistance is high, windings are open.

NOTE — Delta windings on 27 SI series alternators cannot be checked for open circuits.

Stator Checks For Shorts — Refer to Fig. 7 and make test connections as shown using an Ohmmeter. **NOTE** — Ohmmeter should read in tenths (0.1) of an ohm. Results of all three tests should indicate equal resistance in all three winding phases. If not, a short exists and stator must be replaced.

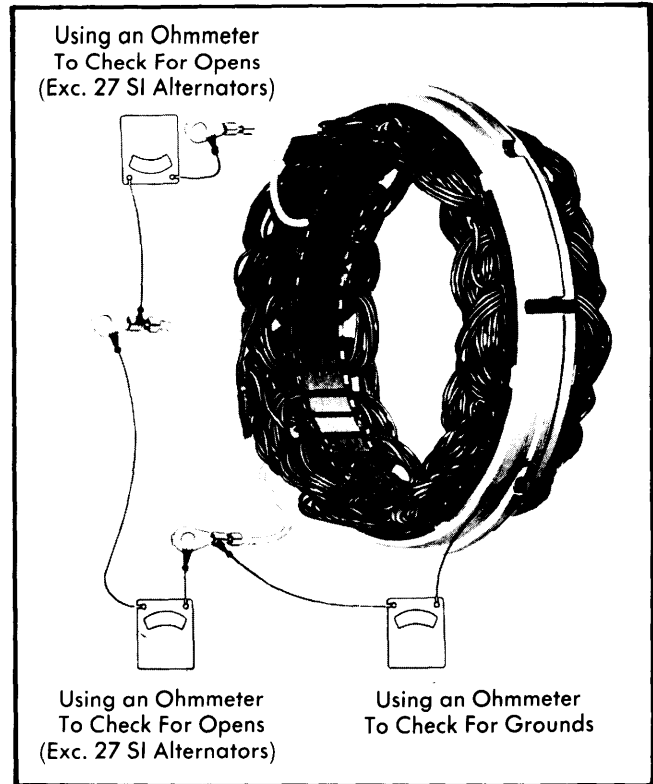

Fig. 6 Bench Testing Stator for Open or Grounded Circuits Using an Ohmmeter

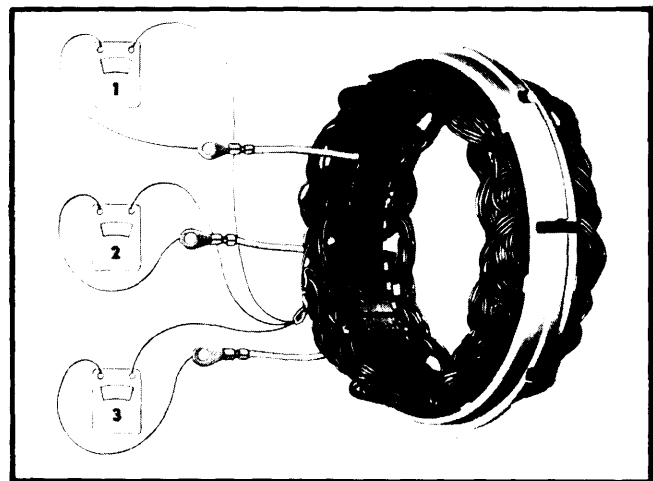

Fig. 7 Bench Testing Stator Windings For Shorts Using an Ohmmeter

Diode Trio — **NOTE** — One of two different diode trios may be used. Both are tested the same and can also be interchanged. With diode trio removed from end frame, connect an Ohmmeter to the single contact and to one of the three connectors. Observe reading, then reverse leads on the same connectors. A good diode trio will give one high and one low reading. If both readings are the same, replace diode trio. Repeat tests between single connector and each of the other two connectors. **NOTE** — Before replacing diode trio, also check rectifier bridge. Do not use high voltage, such as a 110 volt test lamp, to check diode trio.

Alternators & Regulators

DELCO-REMY WITH INTEGRAL REGULATOR (Cont.)

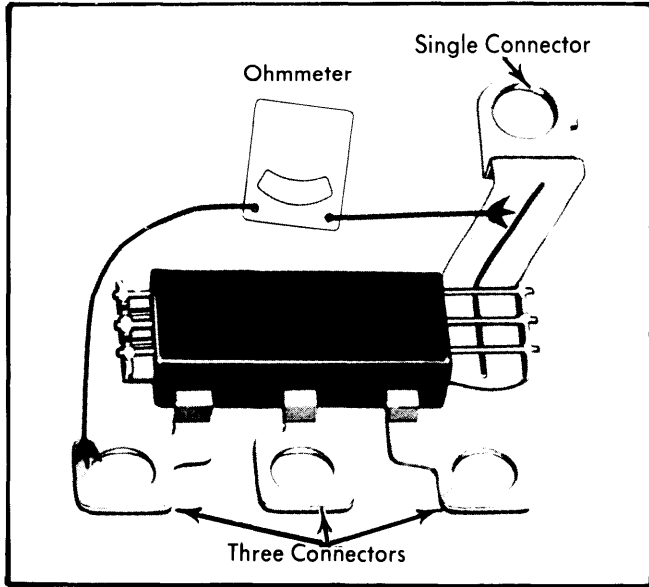

Fig. 8 Bench Testing Typical Diode Trio Using an Ohmmeter

Rectifier Bridge Check – Connect an Ohmmeter to the grounded heat sink and one of the three terminals. Then reverse lead connections to heat sink and same terminal. If both readings are the same replace the bridge. A good rectifier bridge will give one high and one low reading. Repeat test on all terminals. When this is done you will have checked all six diodes with two readings taken for each diode. Do not use high voltage such as a 110 volt test lamp to check bridge.

NOTE – Do not replace diode trio or rectifier bridge unless at least one pair of readings is the same.

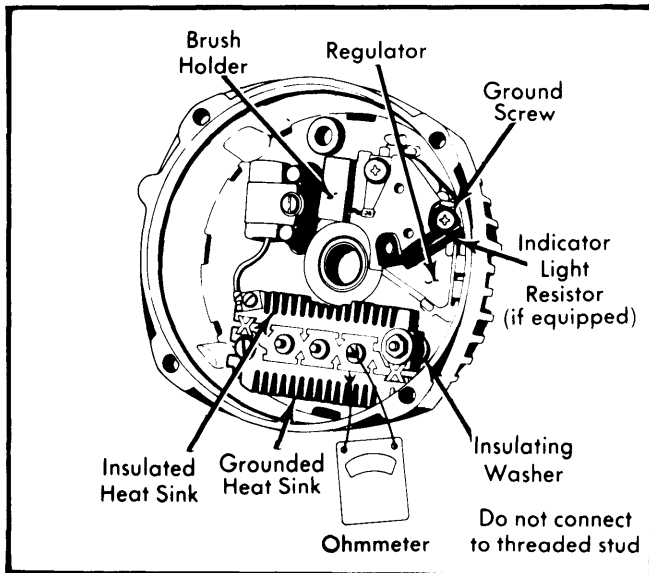

Fig. 9 Bench Testing Rectifier Bridge and Identification of End Frame Components

Voltage Regulator Brush Lead Clip Check – Connect an Ohmmeter from brush lead clip to end frame (see illustration). Then reverse leads, if both readings are zero, either the brush lead clip is grounded or the regulator is defective. A grounded brush lead clip can result from omission of the insulating washer, insulating sleeve on screw, or a damaged insulating sleeve. Remove screw and inspect insulating sleeve if it is satisfactory, replace regulator unit.

REASSEMBLY

1) Install rotor in drive end frame and attach spacer, fan and pulley. Using an Allen wrench, hold shaft and tighten nut. Install capacitor in slip ring end frame. Position brush holder and regulator assemblies in end frame, install retaining screws. Note the screws retaining brush clips have insulating washers over top of brush clips and special insulating sleeves over screw body above threads. Use wood or plastic toothpicks to retain brushes prior to installing slip ring end frame to drive end frame.

2) Position rectifier bridge to end frame. Install attaching screw and "BAT" terminal screw. Connect capacitor lead to bridge. Position diode trio on rectifier bridge terminal and install screw attaching brush lead clip to brush holder. Insulating washer must be assembled over top of connector. Position stator in end frame. Connect stator leads to rectifier bridge terminals and install attaching nuts. Position slip ring end frame to drive end frame and install thru bolts.

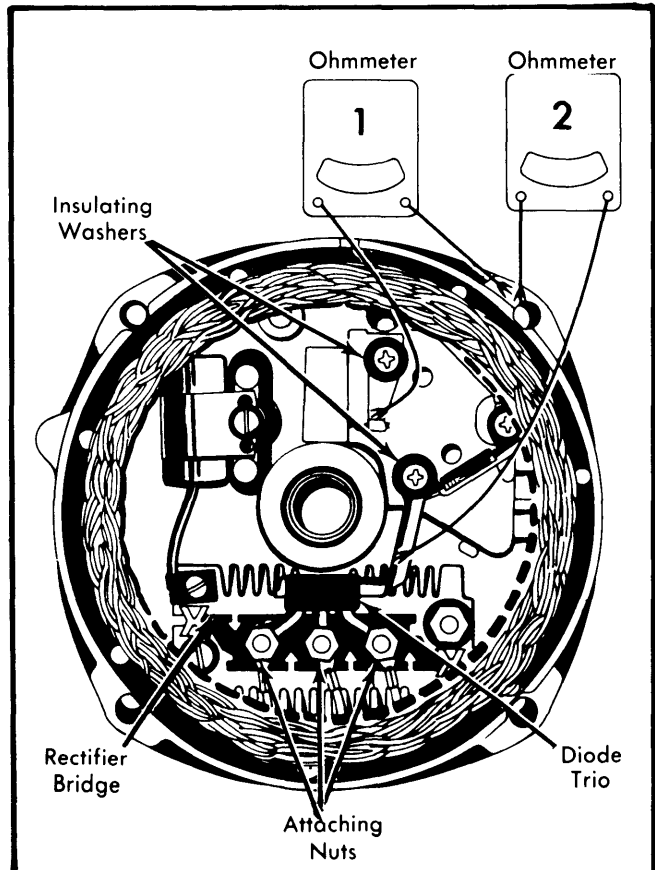

Fig. 10 Bench Testing Voltage Regulator Brush Lead Clips Using an Ohmmeter

DELCO-REMY WITH INTEGRAL REGULATOR (Cont.)

DELCO-REMY DELCOTRON SPECIFICATIONS					
Stamped Rated Amp. Output	Test Specifications (At 14.0 Volts)				Field Current (Amps.) 12 Volts, 80 F
	Amps.	RPM	Amps.	RPM	
32	21	2000	31	5000	4.0-4.5
37	22	2000	33	5000	4.0-4.5
42	25	2000	38	5000	4.0-4.5
55	30	2000	51	5000	4.0-4.5
61	30	2000	57	5000	4.0-4.5
63	32	2000	60	5000	4.0-4.5
80	55	2000	76	5000	4.0-4.9

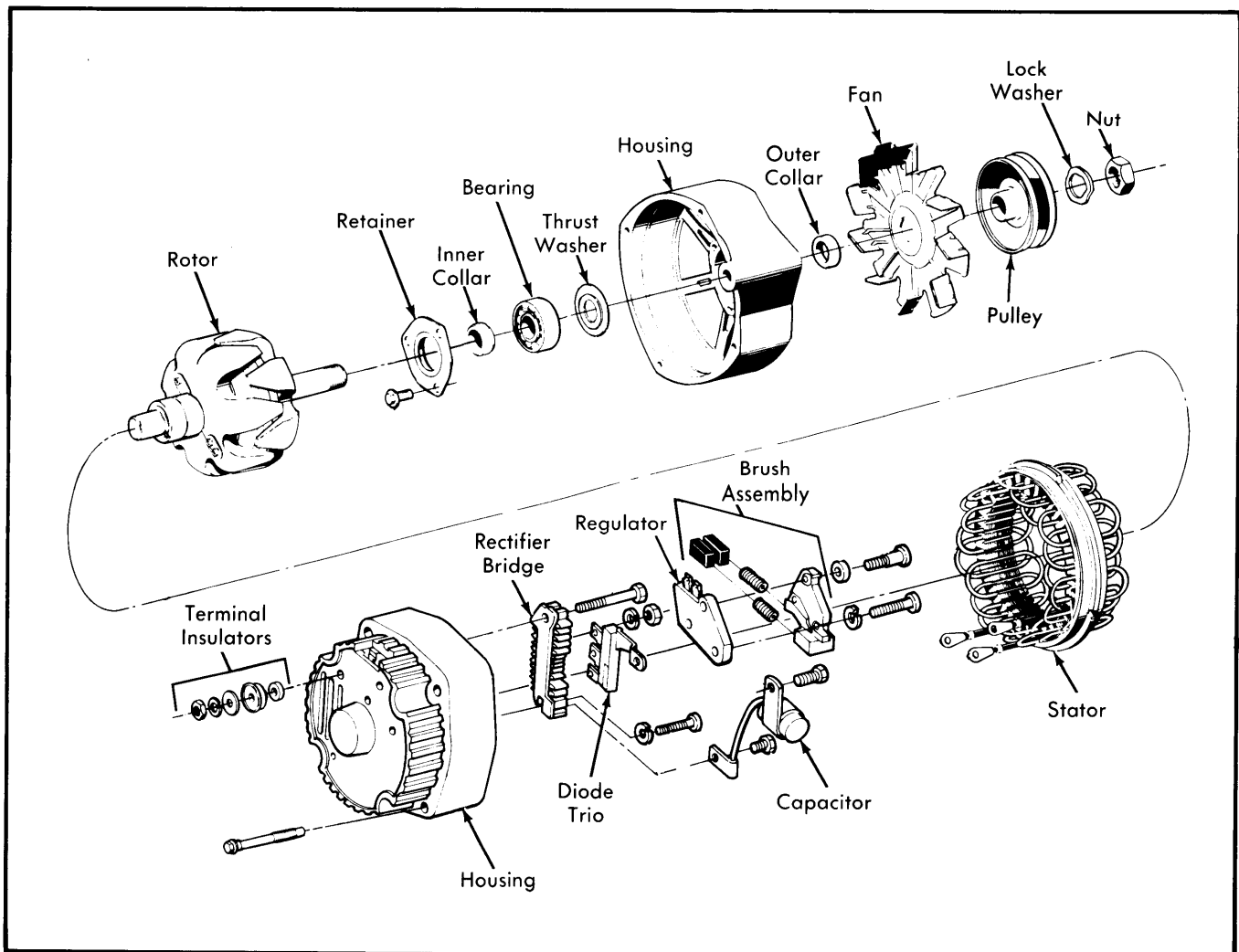

Fig. 11 Exploded View of 10 SI Delcotron
(27 SI Delcotron Similar)

HITACHI ALTERNATORS

International Harvester
6 Cyl. Diesel Models

DESCRIPTION

The alternator is a conventional three-phase, self-rectifying type alternator. Six internal diodes (three positive and three negative) are used to rectify current. The alternator consists of a stator having three windings, a rotor, pulley, end covers to support rotor, brushes and slip rings which supply power to rotor coil.

Application

Model	Hitachi No.
6 Cyl. Diesel Models	
Standard	LT123-38K
Optional	LT123-64K

SPECIFICATIONS

Alternator Test	Specification
Current Output [ⓐ]	24.5 Amps@14 Volts
No Load Voltage [ⓐ]	13.8-14.8 Volts
Field Attraction Current	Approx. 2.4 Amps

ⓐ — At 2500 maximum alternator RPM.

TESTING

FIELD ATTRACTION CHECK

To measure the current flowing through field, connect an ammeter into the circuit (see Fig. 1). A reading of approximately 2.4 amperes should be noted.

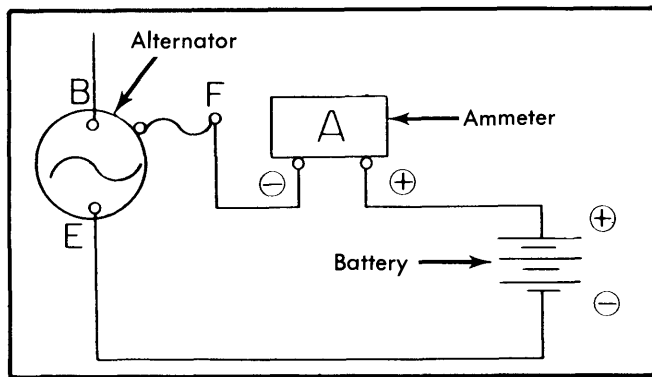

Fig. 1 Measuring the Field Current

DIODE CHECK

Use an ohmmeter to check diodes at alternator connector. Position test leads as shown in following table and results should be as specified in the table. If results are not as specified, disassemble alternator and check diodes.

Diode Continuity Check

Ohmmeter Lead Position		Results
Positive	Negative	
Terminal "A"	Terminal "E"	Continuity
Terminal "E"	Terminal "A"	No Continuity
Terminal "A"	Terminal "N"	Continuity
Terminal "N"	Terminal "A"	No Continuity
Terminal "N"	Terminal "E"	Continuity
Terminal "E"	Terminal "N"	No Continuity

OVERHAUL

DISASSEMBLY

1) Remove nut and take off pulley, fan, and fan base. Remove Woodruff key and spacer for pulley. Remove two attaching screws and brush cover. Remove two screws for brushes and carefully remove brushes. Remove three through bolts and tap alternator using a wooden mallet to separate front and rear.

2) Remove three front bearing retainer screws. Tap front cover from rotor assembly by using a wooden mallet. Remove felt seal. Unsolder lead and diode connections using a 100-200 watt soldering iron and utilizing long nose pliers as a heat sink. **CAUTION** — Try to limit time of heat application to 1-2 seconds at a time as high internal temperatures will destroy the diodes.

3) Separate stator from rear cover. Remove two screws attaching SR holder (for diodes) and remove from rear cover. Remove two attaching screws and remove brush holder.

INSPECTION & REPAIR

Rotor — 1) Apply test probes to slip rings of rotor. If continuity does not exist, then rotor coil is open and must be replaced. Apply test probes to slip ring and rotor core to check ground. If continuity exists, replace rotor assembly.

2) Check slip ring diameter and if less than 1.26", replacement of rotor assembly is necessary as slip rings are not serviced separately. Check slip rings for out-of-round using a dial indicator. If out-of-round is greater than .004", rework slip ring. If out-of-round is greater than .012", replace rotor assembly. Check slip ring friction surfaces to ensure they are not dirty or pitted. If necessary, polish surfaces using fine sandpaper.

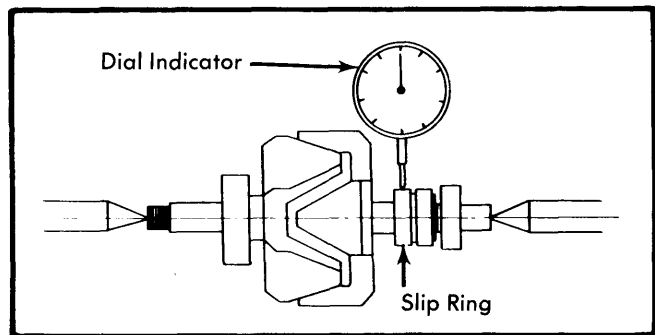

Fig. 2 Checking Slip Ring Out-of-Round

Stator — The stator is normal when there is continuity between individual stator coil terminals. When there is no continuity between terminals, cable is broke and replacement of stator assembly is necessary. If each lead wire of stator coil does not have continuity with stator core, then stator is good. If continuity exists, then stator is grounded and must be replaced.

Diodes — 1) Perform a continuity test on all diodes, in both directions, using an ohmmeter. Test the continuity between each diode and the SR holder or rear cover. If there is continuity in both directions or no continuity in either direction,

HITACHI ALTERNATORS (Cont.)

then diode requires replacement. Continuity should be present in one direction only.

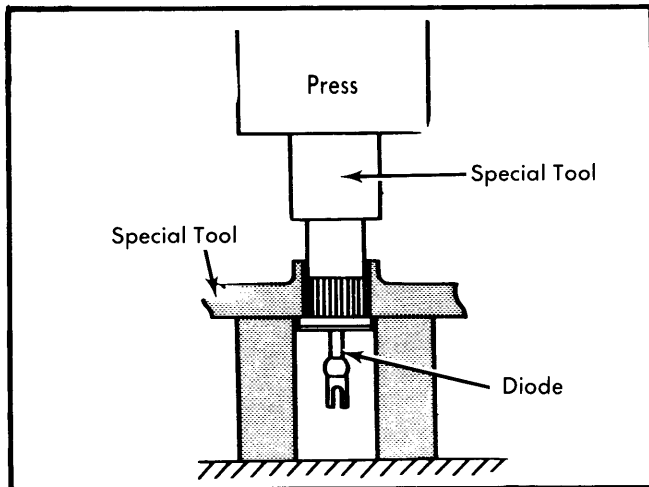

Fig. 3 Removing the Diodes

2) To replace a diode, place the diode with the leads facing up and press out using a suitable tool and press. To install, press in while making sure diode is facing the right direction.

Brushes & Springs — If brushes have a loose pigtail, uneven wear, or are less than .295" in length, then replacement is necessary. Springs must have tension of .463 lbs. and must not be deformed.

Bearings — If bearings are rough then use a press or bearing puller to remove from the rotor shaft. Press the front bearing onto the rotor shaft to the point at which it contacts the spacer. Press the rear bearing onto shaft until it is .689" from the end of shaft.

REASSEMBLY

Reinstall diode assembly and stator to rear cover. Connect lead wires of stator coil to terminals of diode assembly. **NOTE** — Solder quickly to avoid damage to diodes. Install felt seal and reinstall front cover to rotor. Install front bearing retainer screw and three through bolts. Position assembly in vise and install pulley and related components to rotor shaft. Assemble brushes to brush holder and install holder into alternator.