

Windshield Wipers

G.M. 2-SPEED ELECTRIC - SQUARE MOTOR

Chevrolet
"P" Models
GMC
"P" Models

DESCRIPTION

Two speed motor is a compound wound (series and shunt) type. Gear train consists of a helical gear at end of armature shaft which drives an intermediate gear and pinion assembly. Pinion drives output gear and shaft; and crank arm, attached to output gear shaft, drives wiper transmissions through connecting link arms. Circuit protection for wipers is through a fuse on fuse block. Windshield washer pump is a positive displacement type using a piston arrangement. Pump is mounted on shaft of wiper output gear.

TESTING & TROUBLE SHOOTING

WIPER ON CAR

Wiper Inoperative — Check wiring harness, wiper ground strap and dash switch for proper connections and mounting. Check fuse. With ignition switch on, check for 12 volts at harness terminal which connects to No. 2 terminal. To bypass switch, disconnect wiring at motor and connect jumper wire from No. 1 and 3 terminals to ground and a 12 volt source to No. 2 terminal. If wiper does not operate, disconnect transmissions from crank arm. If wiper still does not operate, remove from vehicle and test unit. See *Wiper Off Car*.

Wiper Will Not Shut Off — Determine whether wiper has both speeds, low speed only or high speed only, then operate wiper by bypassing switch as previously outlined. See *Wiper Inoperative*. If wiper operates correctly and has both speeds, lead to switch from No. 1 terminal is grounded or switch is faulty. If wiper has low speed only, lead to switch from No. 3 terminal is open or switch is faulty. If wiper still does not operate, remove from vehicle and test unit. See *Wiper Off Car*.

Operates Low Speed Only & Shuts Off With Dash Switch In High Position — Reverse harness leads connected to No. 1 and 3 terminals.

Does Not Return To Park With Wiper Off — Check ground strap connection and park switch contacts may be dirty, bent or broken.

Speed Normal In Low, But Too Fast In High — Terminal board resistor may be open. Remove from vehicle to test terminal board.

Wiper Operates Intermittently — Loose ground strap or dash switch mounting.

WIPER OFF CAR

NOTE — Use ammeter with reading of 30 amperes (minimum) in feed wire circuit.

Wiper Inoperative — Connect an ammeter and battery to No. 2 terminal and a jumper wire from No. 1 and 3 terminals to ground. Wiper should operate at low speed. If ammeter reading is 0, check for loose splice joints or loose solder connection at No. 2 terminal. If reading is 1-1.5 amperes, check for sticking brushes, open armature or loose splice joint. If reading is 11 amperes, check for broken gear or other stalling condition.

Low Speed — As Shown

High Speed — Disconnect Jumper Wire From Terminal No. 3

Off — Leave Jumper Connected To Terminals But Disconnect At Ground

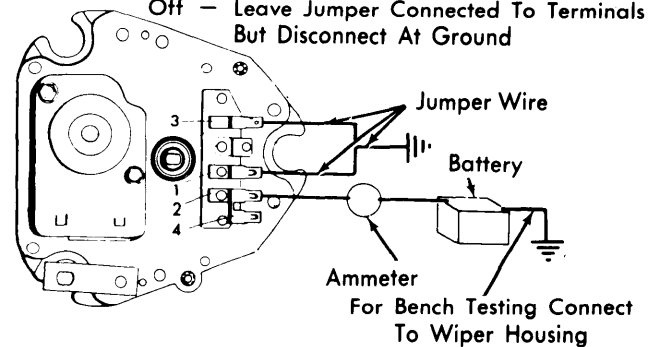

Fig. 1 Test Connections for 2-Speed Wiper

Wiper Will Not Shut Off — If wiper has both speeds, park switch contacts may not be opening or internal motor lead to No. 1 terminal is grounded. If wiper has low speed only, shunt field coil may be grounded or internal wiper lead to No. 3 terminal is grounded. If wiper has high speed only, shunt field is open or internal lead to No. 3 terminal is open.

Wipers Operate Intermittently — Check for sticking brushes, loose splice joints or other loose connections.

WASHER (ON CAR)

Washer Inoperative — 1) Check the following: Sufficient solution in jar; hoses undamaged and connections tight; screen in jar cover hose not plugged; electrical connections tight; nozzle not plugged. If washer still inoperative, start wiper motor only, then push washer button and listen for click of washer relay.

2) If relay click is heard, listen for soft clicking of pump ratchet wheel rotating. If soft click is not heard, pump is faulty. If soft click is heard and pump does not operate, check the following: Proper gear engagement. Check that cam gear teeth are not damaged. Valve assembly.

3) If no relay click heard, check for voltage at washer No. 2 terminal. No voltage indicates faulty wiring. If voltage is correct, connect a jumper wire from washer No. 1 terminal to ground and turn on wiper. If washer relay clicks now and pump operates correctly, dash switch is faulty or there is an open circuit between pump and switch. If no click heard, relay coil is open.

WASHER (OFF CAR)

Washer Inoperative — 1) Remove pump cover and connect a battery to washer No. 2 terminal and to ground. Connect a jumper wire from No. 1 terminal to ground. Turn ratchet pawl so holding contacts are closed. Pawl should be pulled toward relay pole and engage ratchet teeth. If not, relay coil is open.

2) If relay and ratchet pawl operate correctly, manually rotate three-lobe cam clockwise (looking at cam). Relay holding contacts should close and pump plunger arm should release from lock out position. Disconnect jumper wire from No. 1 terminal. Relay coil should remain energized and hold ratchet pawl against ratchet wheel. If not, holding contacts are dirty or open.

G.M. 2-SPEED ELECTRIC - SQUARE MOTOR (Cont.)

3) If pump operated properly in step 2) , manually rotate three-lobe cam until ratchet wheel has turned 360° or 21 teeth. At this point, holding contacts should be opened by hump on wheel and pump plunger arm should be in lock out position.

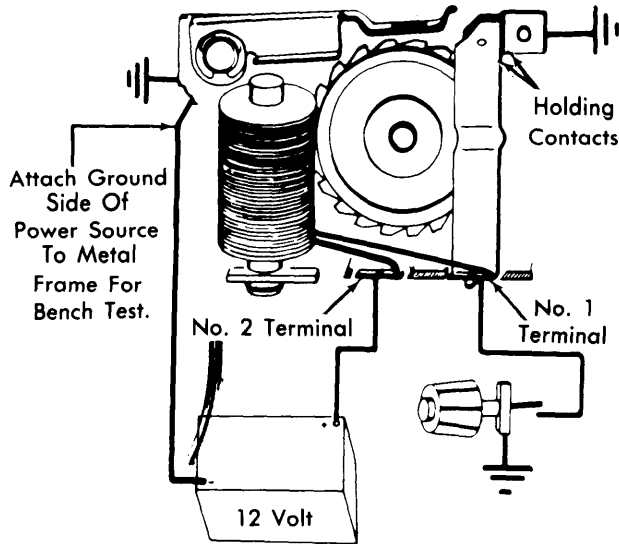

Fig. 2 Test Connections for Washer Pump

Specifications

Current Draw (Amps.)	
No Load (Max.)	3.6
Stall (Max.)	12.0
Crank Arm Speed (RPM-No Load)	
Low Speed (Min.)	34
High Speed (Min.)	65

OVERHAUL

GEAR BOX

Disassembly — Remove washer pump, if equipped. Remove pump drive cam by wedging off shaft using two screwdrivers. Clamp crank arm in vise and remove retaining nut. **CAUTION** — Arm must be secured in vise to avoid stripping wiper gears. Remove crank arm, seal cap, retaining ring and end play washers. Drill out gear box cover rivets and remove cover. Remove output gear and shaft assembly, then slide intermediate gear and pinion assembly off shaft. Remove terminal board and park switch by unsoldering motor leads from terminals and drilling out rivets holding terminal board and park switch ground strap to plate.

Reassembly — **NOTE** — Service kit is available which contains necessary screws, nuts and washers to replace rivets removed at disassembly. Reverse disassembly procedure while noting the following: Lubricate gear teeth with suitable cam lubricant. Cover must be positioned over locating dowel pins. Ground strap must be reconnected. Place wiper in park position, install crank arm on output shaft so identification marks line up with marks in cover. Clamp crank in vise before tightening retaining nut.

WIPER MOTOR

Disassembly — Disassemble gear box, remove through bolts, tap motor frame lightly and remove motor from mounting plate. Release brush spring tension and slide armature and endplate from motor frame. Pull endplate from armature. **NOTE** — A thrust plug is located between armature shaft and endplate. Remove endplay adjusting washers and note arrangement for proper reassembly.

Reassembly — Reverse disassembly procedure while noting the following: Lubricate armature shaft bushings with light machine oil. Install washers with concave side of washers toward each other. Endplay is automatically controlled by proper installation of washers.

WASHER PUMP (PISTON TYPE)

Solenoid Assembly (Ratchet Dog) — Squeeze cover to remove. Remove ratchet dog retaining screw. Hold solenoid plunger in position and lift solenoid assembly and ratchet dog from pump frame. Separate ratchet dog from solenoid mounting plate as required. To install, reverse disassembly procedure.

Ratchet Pawl — Disconnect ratchet pawl spring, remove pawl retaining ring and slide ratchet pawl off cam follower shaft. To install, reverse removal procedure.

Ratchet Wheel — Remove ratchet dog from pump frame, move ratchet wheel spring out of shaft groove and slide ratchet wheel off its shaft. To install, reverse removal procedure.

Pump And Actuator Plate Assembly — Remove solenoid assembly, ratchet dog, ratchet pawl and ratchet wheel. To separate pump and pump actuator plate from frame, pull pump housing in direction of arrow until grooves in housing clear the frame. Remove actuator plate from ratchet wheel and cam follower shafts. To install, reverse removal procedure.

Valve Assembly — Remove screws attaching valve assembly to pump housing. During reassembly, gasket must be properly positioned between housing and valve plate in the housing and valve plate grooves. Triple "O" ring must be properly installed between valve body and pipe assembly.

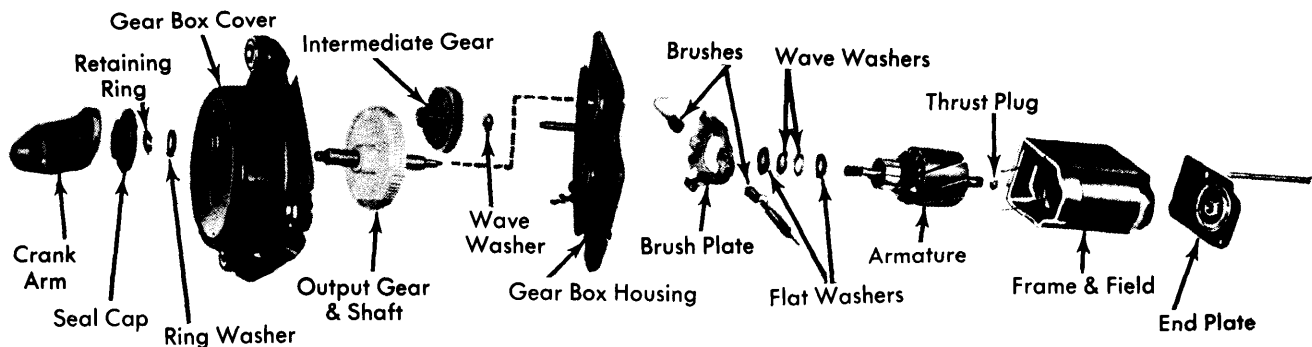

Fig. 3 Exploded View of Wiper Motor & Drive Assembly