

## GENERAL MOTORS

Chevrolet  
GMC

## REMOVAL &amp; INSTALLATION

## SPEEDOMETER &amp; GAUGES

**All Models** — All instruments and gauges are installed in the instrument cluster. Instrument cluster must be removed from vehicle for replacement of components.

## INSTRUMENT CLUSTER

**"C" & "K" Models** — Disconnect battery ground cable. Remove instrument cluster bezel and steering column cover screws, remove both bezel and cover. Remove clock knob (if equipped). Remove lens retaining screws and lens. Remove transmission quadrant indicator retaining screws and remove indicator. Remove cluster retainer. Reach up under dash and disconnect speedometer cable by depressing spring clip, and pull out cable. Disconnect oil pressure line (if equipped). Disconnect cluster wiring harness, remove cluster retaining screws, and remove cluster. Move cluster assembly to suitable work area for further disassembly. To install, reverse removal procedure.

**"G" Models** — Disconnect battery ground cable. Reach up under instrument cluster and disconnect speedometer cable by first depressing tang on rear of speedometer head and

pushing, then pulling, cable free from head as tang is depressed. Unplug electrical harness connector from printed circuit. Disconnect oil pressure line from gauge (if equipped) and remove two nuts attaching instrument cluster studs to lower opening in instrument panel, and lift out bottom of cluster. Remove cluster to suitable work area for further disassembly. To install, reverse removal procedure.

## PRINTED CIRCUITS

**All Models** — Remove instrument cluster and remove all cluster light assemblies. Remove printed circuit retaining screws. Remove fuel, temperature, and ammeter terminal nuts holding printed circuit to cluster cover. Remove printed circuit from rear of instrument cluster. To install, reverse removal procedure while noting that retaining screws serve as ground for printed circuit and must be properly reinstalled to provide proper ground connection.

## HEADLIGHT SWITCH

**All Models** — Disconnect battery ground cable. Reach up behind instrument cluster and depress shaft retaining button to remove switch knob and rod. Remove instrument cluster switch retaining nut, and push switch from panel opening and remove electrical connections at switch terminals. Reinstall by reversing removal steps, making sure ground wire is reinstalled where applicable.

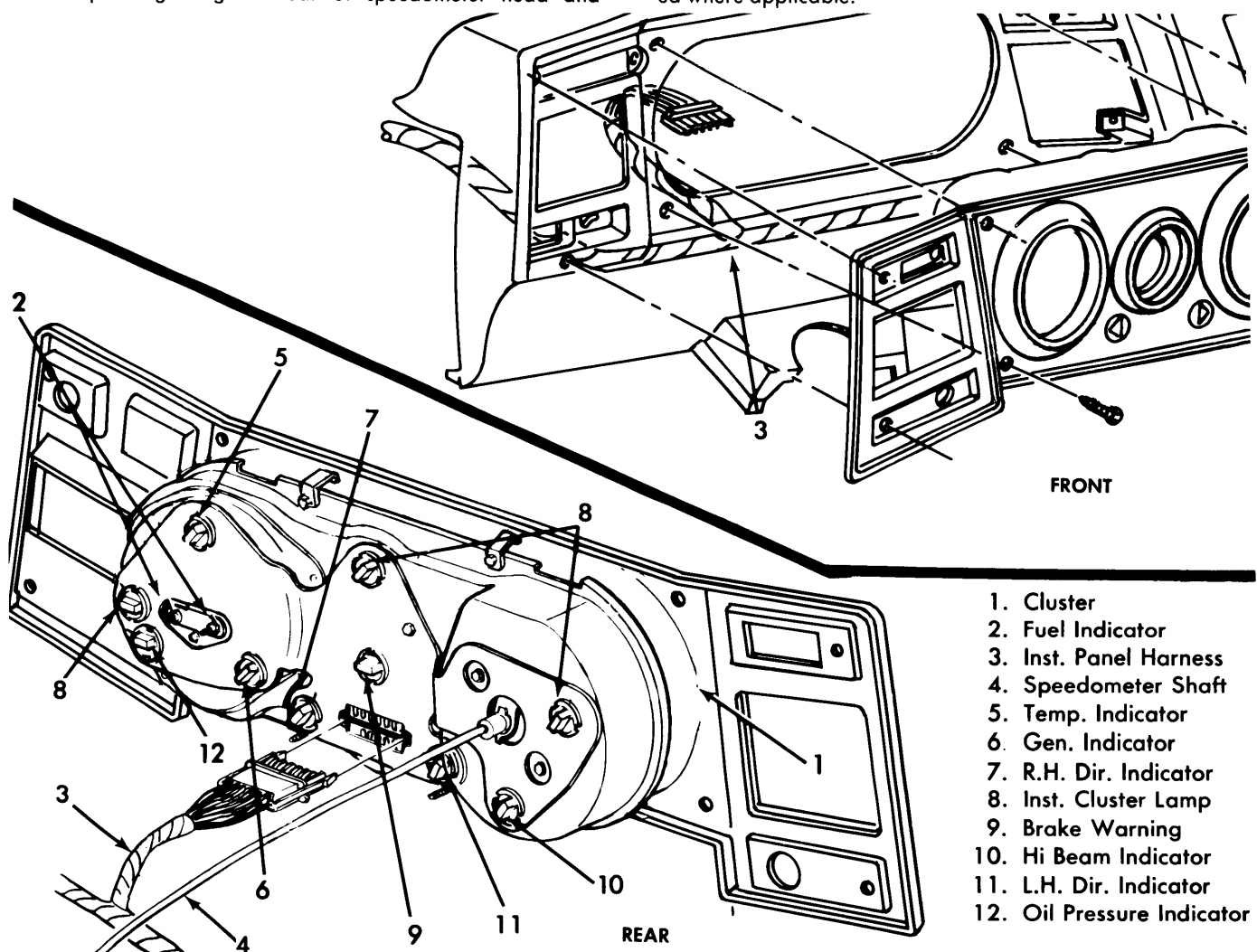

Fig. 1 "G" Models Instrument Cluster

## GENERAL MOTORS (Cont.)

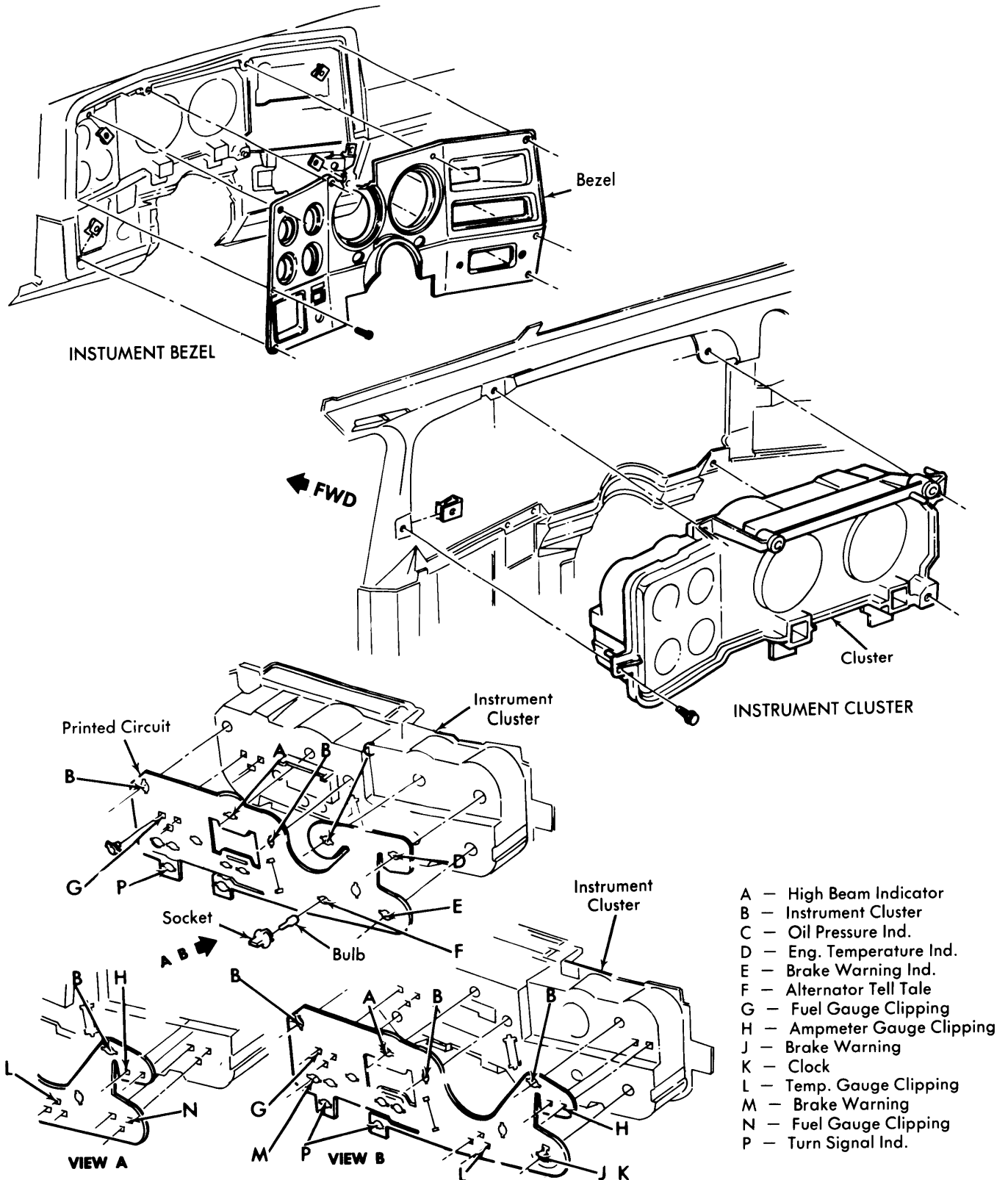

Fig. 2 "C" & "K" Models Instrument Cluster