

DELCO-REMY WITH INTEGRAL REGULATOR

Chevrolet
GMC
 International Harvester
 Jeep

NOTE — Jeep models with V8 engines use a Motorcraft alternator. See Motorcraft With Separate Regulator Alternators in this section.

Application	Delco-Remy Part No.	Amperes
W/Air Cond.		
CJ5 & CJ7	1102879	55
Cherokee & J10	1100928	55
Fleet Option		
Cherokee & J10	1102465	63

DESCRIPTION

Delcotron integral alternator-regulator features a solid state regulator mounted inside generator slip ring end frame. Regulator components mounted inside alternator are enclosed into a solid mold which, along with brush holder assembly, is attached to slip ring end frame. Stator windings assembled on inside of laminated core form part of alternator frame. Rectifier bridge connected to stator windings contains six diodes which change stator a.c. voltage to d.c. at alternator output terminal. A diode trio connected to stator windings supplies alternator field current while capacitor mounted in end frame protects rectifier bridge and diode trio from high voltages.

ALTERNATOR APPLICATION

Application	Delco-Remy Part No.	Amperes
Chevrolet & GMC		
Standard		
250" All Models	1102491	37
292"		
"C" & "K" Models ...	1102887	37
"G" & "P" Models ...	1102394	37
350", 400", & 454"		
All Models	1102394	37
455" Motor Home	1101016	80
W/Air Cond. or 61 Amp. Option		
250" All Models	1102486	61
292"		
"C", "K", "G" Models	1102886	61
"P" Models	1102888	61
350", 400" & 454"		
All Models	1102480	61
W/H.D. Heater & Defroster		
250" All Models	1102478	55
292" All Models	1102885	55
340", 400" & 454"		
All Models	1102479	55
Optional		
250" All Models	1102485	42
292" All Models	1102887	42
350", 400" & 454"		
All Models	1102841	42
International Harvester		
Standard		
All Models	1102848	37
W/Air Cond. or Trailer Tow Package		
All Models	1102849	37
Jeep		
Standard		
CJ5 & CJ7	1102877	37
Cherokee & J10	1100927	37

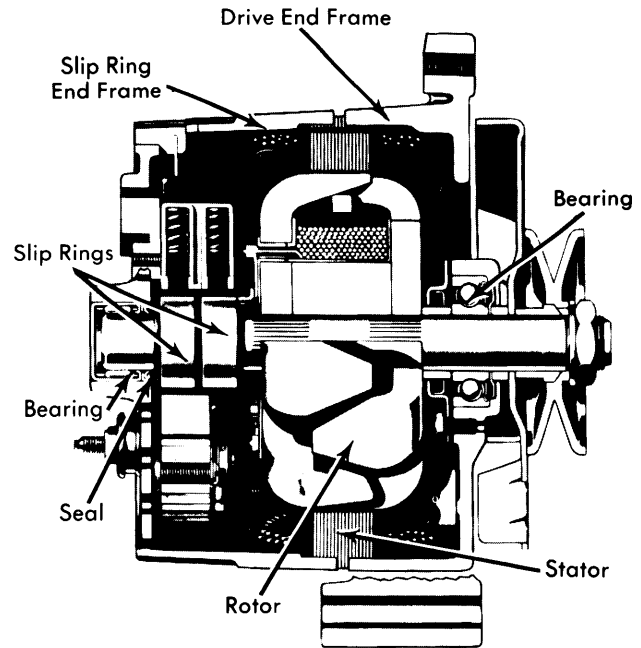

Fig. 1 Cross Section of Delcotron

ADJUSTMENTS

No periodic adjustments or maintenance is required for alternator assembly. Regulator voltage is preset and no adjustment is provided.

CAUTION — Do not attempt to polarize alternator. Do not short or ground any terminals except as instructed. Never operate alternator with battery out of circuit or output terminal open. Alternator and battery must share same ground polarity.

TESTING

NOTE — Before making any electrical checks, visually inspect all connections, including slip on connectors to make sure all are clean and tight. Be sure alternator mounting bolts are tight and belt has proper tension, also be sure unit is properly grounded.

UNDERCHARGED BATTERY

1) With ignition switch "ON", connect a voltmeter from alternator "BAT" terminal to ground, then from No. 1 terminal to ground, and No. 2 terminal to ground. A zero reading indicates an open between connection and battery. An open No. 2 lead will cause uncontrolled voltage. Opens in this circuit may be between terminals at crimp between harness wire and terminal, or in wire. If preceding checks are satisfactory, proceed as follows:

DELCO-REMY WITH INTEGRAL REGULATOR (Cont.)

2) Disconnect battery ground cable. Connect an ammeter in the circuit at the "BAT" terminal of alternator. Reconnect battery ground cable. Turn on all available accessories. Connect a carbon pile across battery. Operate engine at moderate speed and adjust carbon pile as required to obtain maximum current output. If ampere output is within 10% of rated output as stamped on alternator frame, alternator is not defective. If output is not within 10% of rated output, ground the field winding by inserting a screwdriver into test hole (see Fig. 2). **CAUTION** — Tab is within $\frac{3}{4}$ " of casting surface, do not force screwdriver deeper than one inch into end frame.

3) Operate engine at moderate speed as required and adjust carbon pile for maximum output. If output is now within 10% of rated output with fields grounded, regulator is defective and requires replacement. If output is still not within 10% of rated output, check field winding, diode trio, rectifier bridge, and stator.

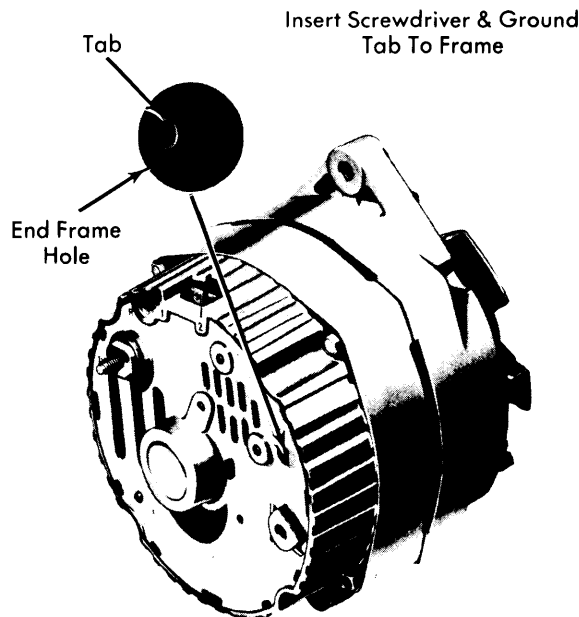

Fig. 2 Grounding Fields Test

ALTERNATOR OUTPUT TEST

1) To bench check alternator proceed as follows: Make connections as shown in Fig. 3 except leave carbon pile disconnected. Use a fully charged battery, and a 10 Ohm resistor rated at 6 watts or more between alternator No. 1 terminal and battery. Slowly increase alternator speed and observe voltage. If voltage is uncontrolled with speed and increases above 16 volts, check for a grounded brush lead clip. If brush lead clip is good, replace regulator.

2) Connect carbon pile. Operate alternator at moderate speed and adjust carbon pile to obtain maximum output. If output is within 10% of rated output as stamped on alternator frame, alternator is good. If not, ground alternator field with a screwdriver. If output can be adjusted to within 10% of rated output with field grounded, replace regulator. If output is not within specifications, check field winding, diode trio, rectifier bridge and stator.

OVERCHARGED BATTERY

1) Connect voltmeter from alternator No. 2 terminal to ground. If reading is zero, No. 2 lead circuit is open. If check is good and overcharge condition still exists, proceed with testing.

2) Separate end frames and connect ohmmeter, using lowest range scale, from brush lead clip to end frame and then reverse connections. If both readings are zero, either brush lead clip is grounded or regulator is defective. Grounded brush lead clip can result from omission of insulating washer, or insulating sleeve over screw, or damaged sleeve. Remove screw to inspect sleeve, replace regulator if insulating components are satisfactory.

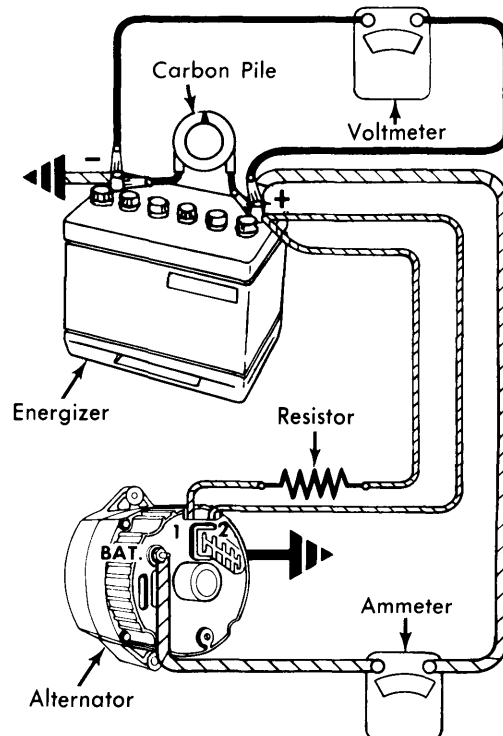

Fig. 3 Bench Test Connections

OVERHAUL

DISASSEMBLY

1) Hold alternator in a vise, clamping mounting flange lengthwise. Remove through bolts and separate slip ring end frame and stator assembly from drive end and rotor assembly by prying apart with a screwdriver at stator slots. **NOTE** — Scribe marks will help relocate parts during reassembly.

2) Place a piece of tape over slip ring end frame bearing to prevent entry of dirt. At this point brushes may drop onto rotor shaft and become contaminated with bearing lubricant, clean brushes as soon as possible with a suitable cleaner (acetone) to keep them from becoming grease soaked.

DELCO-REMY WITH INTEGRAL REGULATOR (Cont.)

3) Remove stator lead attaching nuts and separate stator from end frame. Remove screw attaching diode trio to brush holder and remove diode trio from end frame. Remove rectifier bridge attaching screw and "BAT" terminal screw, and disconnect capacitor lead. Remove rectifier bridge from end frame. Remove brush holder and regulator. Note that two insulators are assembled over top of brush retaining clips, and that the two screws have special insulating sleeves.

4) Remove capacitor from end frame. Remove slip ring end frame bearing if necessary. Remove pulley nut by holding shaft with an Allen wrench. Remove pulley. Remove rotor and spacers from drive end frame assembly. If necessary remove drive end frame bearing retainer plate, then gasket and bearing.

INSPECTION

Wash all metal parts except bearings, stator and rotor. Inspect rotor slip rings and if cleaning is necessary, use 400 grain polishing cloth. Slip rings may be trued with a lathe to .002" indicator reading. Slip rings are not replaceable and excessive damage will require rotor replacement. Inspect brushes for wear and if worn halfway, replace brushes. Clean bearings and inspect for pitting or roughness.

TESTING

Rotor Field Winding — Check rotor for open or shorted circuits using a suitable 110 volt test lamp or ohmmeter. To test for open circuit, connect one test lamp or ohmmeter lead to each slip ring. If lamp fails to light or if ohmmeter reading is high, windings are open. To test for short circuit, connect a 12 volt battery and an ammeter in series with two slip rings. Current draw must be within specifications. Excessive current draw indicates shorted windings.

Stator Checks — To check for grounds, connect a 110 volt test lamp or an ohmmeter from any stator lead to stator frame. If test lamp lights or if ohmmeter reads low, windings are grounded. To check for open circuit, successively connect ohmmeter or test light between each pair of stator leads. If lamp fails to light or if ohmmeter reads high, windings are open. A short in stator windings is difficult to locate due to low resistance of windings. If all other electrical checks are normal and alternator fails to supply rated output, shorted stator windings are indicated; also look for heat discoloration on windings.

Diode Trio — With diode trio removed from end frame, connect an ohmmeter to single contact and one of the three connectors. Observe reading, then reverse leads on same connectors. A good diode trio will give one high and one low reading. If both readings are the same, replace diode trio. Repeat test between single connector and each of two other connections. **CAUTION** — Do not use high voltage such as a 110 volt test lamp to check diode trio.

Rectifier Bridge Check — Connect an ohmmeter to grounded heat sink and one of the three terminals. Reverse lead connections to heat sink and same terminal. If both readings are same, replace bridge. A good rectifier bridge will give one high and one low reading. Repeat test on all terminals. **CAUTION** — Do not use high voltage such as 110 volt test lamp to check bridge.

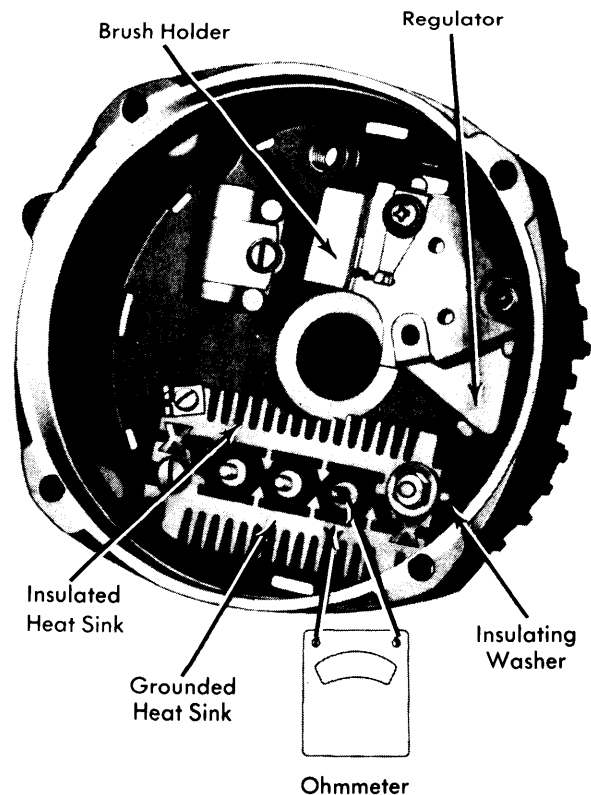

Fig. 4 Checking Rectifier Bridge

Voltage Regulator Brush Lead Clip Check — Connect an ohmmeter from brush lead clip to end frame. Reverse leads and if both readings are zero, either brush lead clip is grounded or regulator is defective. A grounded brush lead clip can result from omission of insulating washer, insulating sleeve on screw or a damaged insulating sleeve. Remove screw and inspect insulating sleeve, replace regulator unit if insulating components are satisfactory.

REASSEMBLY

1) Install rotor in drive end frame and attach spacer, fan and pulley. Using an Allen wrench, hold shaft and tighten nut. Install capacitor in slip ring end frame. Position brush holder and regulator assemblies in end frame and install retaining screws. **NOTE** — Screws retaining brush clips have insulating washers over top of brush clips and special insulating sleeves over screw body above threads. Use suitable pins to retain brushes prior to installing slip ring end frame to drive end frame.

2) Position rectifier bridge to end frame. Install attaching screw and "BAT" terminal screw. Connect capacitor lead to bridge. Position diode trio on rectifier bridge terminal and install screw attaching brush lead clip to brush holder. Insulating washer must be assembled over top of connect. Position stator in end frame. Connect stator leads to rectifier bridge terminals and install attaching nuts. Position slip ring end frame to drive end frame and install through bolts.

Alternators

DELCO-REMY WITH INTEGRAL REGULATOR (Cont.)

DELCO-REMY DELCOTRON SPECIFICATIONS						
Delco-Remy Number	Rating (Amps.)	Test Specifications (At 14.0 Volts)				Field Current (Amps.) 12 Volts, 80° F
		Amps.	RPM	Amps.	RPM	
1100927	37	22	2000	33	5000	4.0-4.5
1100928	55	30	2000	51	5000	4.0-4.5
1101016	80	55	2000	76	5000	4.4-4.9
1102394	37	22	2000	33	5000	4.0-4.5
1102465	63	32	2000	60	5000	4.0-4.5
1102478	55	30	2000	51	5000	4.0-4.5
1102479	55	30	2000	51	5000	4.0-4.5
1102480	61	30	2000	57	5000	4.0-4.5
1102485	42	25	2000	38	5000	4.0-4.5
1102486	61	30	2000	57	5000	4.0-4.5
1102491	37	22	2000	33	5000	4.0-4.5
1102841	42	25	2000	38	5000	4.0-4.5
1102848	42	25	2000	38	5000	4.0-4.5
1102849	63	32	2000	60	5000	4.0-4.5
1102877	37	22	2000	33	5000	4.0-4.5
1102879	55	30	2000	60	5000	4.0-4.5
1102885	55	30	2000	51	5000	4.0-4.5
1102886	61	30	2000	57	5000	4.0-4.5
1102887	42	25	2000	38	5000	4.0-4.5
1102888	61	30	2000	57	5000	4.0-4.5