

INTERNATIONAL HARVESTER AUTO-CRUISE

International Harvester

DESCRIPTION

System senses vehicle speed through speedometer cable and uses engine intake manifold vacuum to regulate accelerator and automatically maintain any pre-set cruising speed between 30 and 80 MPH.

OPERATION

Auto-Cruise control is an integral part of directional switch lever and consists of two separate switches. The first "OFF-ON" and "RES" (resume) slide switch located on the flat of directional switch lever. Second is a push button switch located at the end of directional switch lever. To engage system, move slide switch to "ON" position and accelerate to desired speed. Depress and release button on end of switch lever. System will automatically disengage when brake pedal is depressed and can be re-engaged to previously selected speed by accelerating to 30 MPH and moving slide switch to "RES" position, then releasing switch. *NOTE* — When slide switch is moved to "OFF" position, pre-set speed of "RES" function is cancelled and must be reset when system is reactivated. A higher speed can be set by pressing on accelerator pedal until new speed is reached and then pushing control button. A lower speed can be achieved by lightly depressing brake pedal, allowing vehicle to slow to desired speed and then depressing push button. Operation of individual components is as follows:

Control Switch — An integral part of turn signal lever, when actuated it will energize either solenoid valve or coupling coil (or both), thereby controlling speed.

Vacuum Servo — A neoprene bellows which is used to vary throttle operation in relation to the vacuum supplied to regulator assembly.

Release Switches (Electric & Vacuum) — Release switches disengage system when brake pedal is depressed.

Regulator — Senses speed through speedometer cable located between transmission and regulator. Fly-weight type governor reacts to cable speed and engages low speed switch at approximately 30 MPH. When low speed switch is closed, driver may engage system. Regulator is serviced as an assembly.

TROUBLE SHOOTING & DIAGNOSIS

SYSTEM WILL NOT ENGAGE

System harness fuse blown. Defective control switch. No current to brown wire at No. 2 terminal of regulator. Brake switch improperly adjusted. Improper vacuum switch adjustment. Vacuum switch defective. Defective valve body and magnet assembly, or faulty low speed switch requiring regulator replacement.

SYSTEM DOES NOT DISENGAGE WHEN BRAKES APPLIED

Defective brake release switch or adjustment is incorrect. Faulty valve body and magnet assembly requiring regulator replacement.

CARBURETOR DOES NOT RETURN TO NORMAL IDLE

Improper throttle linkage adjustment. Throttle return spring weak or disconnected. Faulty throttle cable linkage.

PULSATING ACCELERATOR PEDAL

Kinked speedometer or drive cable.

SPEED 3 OR MORE MPH ABOVE OR BELOW SELECTED SPEED

Adjustment of regulator incorrect.

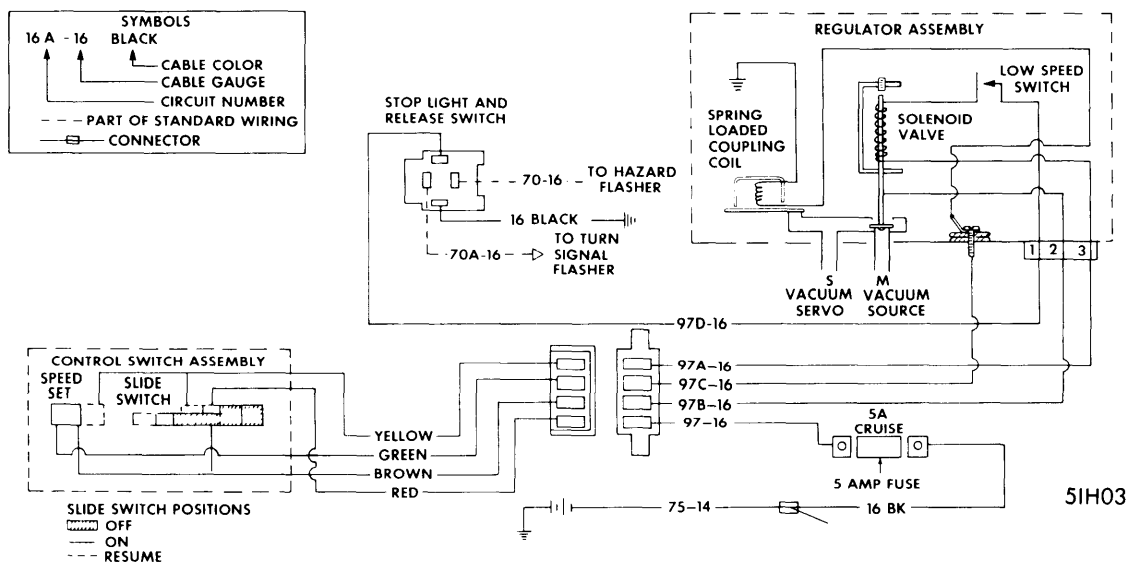

AUTO-CRUISE WIRING DIAGRAM

Automatic Speed Controls

INTERNATIONAL HARVESTER AUTO-CRUISE (Cont.)

SYSTEM WILL NOT CONTROL AT SELECTED SPEED

Faulty vacuum servo or hose. Faulty governor requiring regulator replacement.

TESTING

CONTROL SWITCH CONTINUITY

Control switch continuity test is performed at steering column using an ohmmeter. Refer to the following chart to determine switch continuity condition.

NOTE — Pushbutton cannot be depressed with slide switch in "RES" position.

Control Switch Continuity Conditions

Application	Switch Position	Condition
Red-to-Brown	"OFF"	Open
Red-to-Green	"OFF"	Open
Red-to-Yellow	"OFF"	Open
Red-to-Brown	"ON"	Closed
Red-to-Green	"ON"	Closed
Red-to-Yellow	"ON"	Open
Red-to-Brown	"RES"	Closed
Red-to-Green	"RES"	Closed
Red-to-Yellow	"RES"	Closed
Red-to-Brown	"ON"①	Closed
Red-to-Green	"ON"①	Open
Red-to-Yellow	"ON"①	Closed

① — Pushbutton is depressed.

ADJUSTMENT

CENTERING SPRING

NOTE — Adjustment of centering spring is extremely sensitive. Adjustment screw must never be turned more than $\frac{1}{8}$ turn in either direction.

Auto-Cruise system is designed to maintain speed designated by driver, within 3 MPH. Speed change is made by adjusting spring centering screw. If speed control holds speed more than 3 MPH above designated speed, turn centering spring screw "C" (see illustration) toward "S" $\frac{1}{8}$ of a turn or less. If speed is more than 3 MPH below designated speed, turn centering speed screw "C" toward "F", $\frac{1}{8}$ of a turn or less.

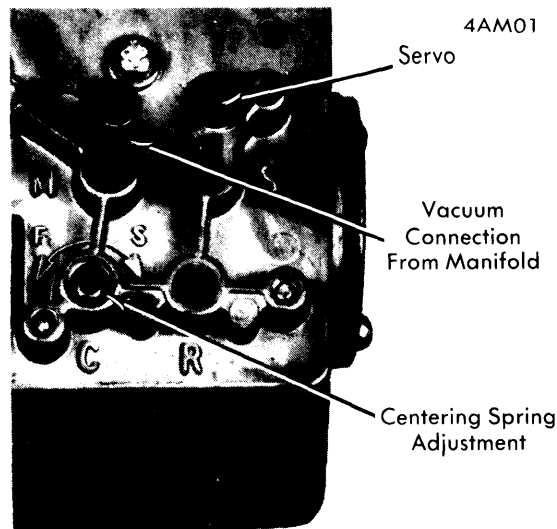

ADJUSTMENT SCREW IDENTIFICATION

VACUUM CONTROL CABLE

Adjust throttle control cable. Align vacuum control cable as shown in illustration by adjusting jam nut at forward end of cable.

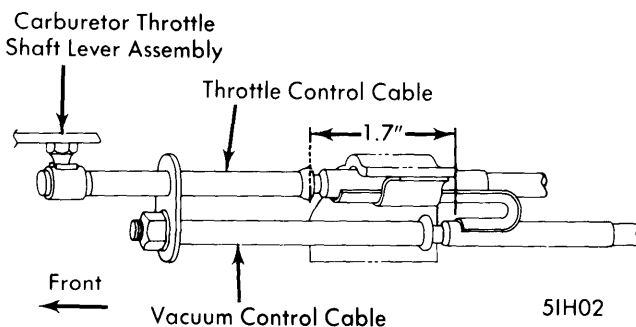

VACUUM CONTROL CABLE ADJUSTMENT

VACUUM RELEASE VALVE

Adjust vacuum release valve assembly with the brake pedal released so that distance between brake pedal lever and body face is .10".

ELECTRIC RELEASE SWITCH

Adjust electric release switch with the brake pedal released so that distance between brake pedal lever and body face is .10".