

CHRYSLER CORP.

Dodge
Plymouth

DESCRIPTION

System is electrically actuated and vacuum operated. Turn signal lever on steering column incorporates a slide switch which has three positions: "OFF", "ON" and "RESUME SPEED". A speed set button is located in the end of lever. System will not function under 30 MPH.

OPERATION

Engaging System — Move slide switch to "ON" position, attain desired speed, then momentarily depress and release speed set button. Remove foot from accelerator and speed will be maintained at selected level. Moving slide switch from "OFF" to "ON" while car is in motion establishes memory without system engagement at that speed.

Disengaging System — Normal brake application or a soft tap on brake pedal will disengage control unit without erasing speed memory. Moving slide switch to "OFF" or turning ignition off also disengages system and in addition, erases speed memory.

Resuming Speed — Move slide switch to "RESUME" position.

Changing Speed Setting — To increase speed, accelerate to desired speed and momentarily depress and release speed set button. When unit is engaged, tapping button will increase speed in small amounts. To decrease speed, tap brake pedal lightly to disengage system. When desired speed has been obtained, depress and release speed set button. Decrease in speed can also be obtained by holding set button depressed until desired speed is attained. Releasing button engages system at that speed.

TROUBLE SHOOTING

NO SPEED CONTROL WHEN BUTTON PRESSED

Slide switch in "OFF" position. Fuse blown. Faulty electrical circuit. Vacuum leak. Insufficient brake switch clearance. Speed control throttle cable disconnected.

NO RESUME WHEN SLIDE SWITCH MOVED

Insufficient movement of slide switch. Faulty electrical circuit.

NO AUTO. RELEASE WITH PEDAL DEPRESSED

Speed control cable kinked or damaged. Improper adjustment of brake switch. Faulty electrical circuit.

SPEED CONTROL ENGAGES WITHOUT ACTUATING SPEED SET BUTTON

Faulty electrical circuit.

CARBURETOR DOES NOT RETURN TO NORMAL IDLE

Speed control cable kinked or damaged. Speed control cable improperly adjusted. Standard throttle linkage faulty.

SPEEDOMETER NOISE, EXCESSIVE NEEDLE FLUTTER OR ERRATIC SERVO LOCK-IN PERFORMANCE

Speedometer cable kinked or damaged. Cable core bent or too long. Cable ferrule nut loose at speedometer head, transmission or speed control servo. No lubrication on speedometer cable or core. Noisy speedometer head assembly.

SPEED SETTING AFTER LOCK-IN, TOO HIGH OR TOO LOW

Improper speed control throttle cable adjustment. Vacuum leak. Improper speed control lock-in adjustment.

UNIT DISENGAGES ON ROUGH ROAD

Insufficient brake switch clearance.

RESUME SPEED POSSIBLE BELOW 20 MPH

Faulty low speed inhibit switch in servo unit. Faulty electrical circuit.

SPEED CONTROL ENGAGES WHEN ENGINE STARTED OR DOES NOT DISENGAGE WITH PEDAL DEPRESSED

Faulty electrical circuit.

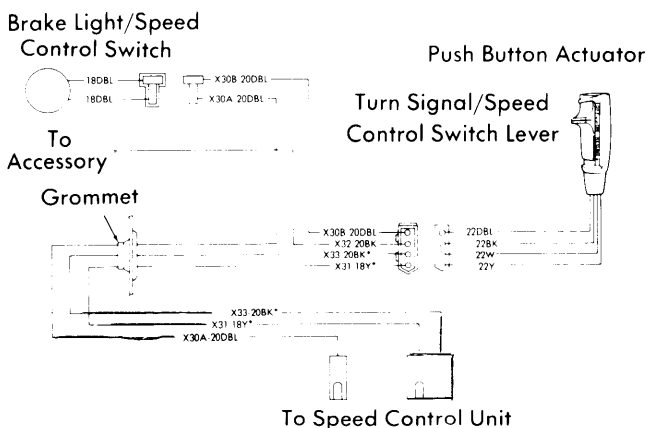

5CR02

COLOR CODE	
BK	Black
DBL	Dark Blue
Y	Yellow
*	With Tracer

SPEED CONTROL WIRING DIAGRAM

TESTING

SPEED CONTROL SWITCH

1) Disconnect 4-wire connector at steering column. Connect a 12 volt positive source to black wire terminal in speed control harness connector (male). With switch in "ON" position, connect a test lamp between connector yellow wire and ground. Lamp should light and then go out when "SPEED SET" button is depressed.

CHRYSLER CORP. (Cont.)

2) Move test lamp lead to connector blue wire. Lamp should light with switch in "ON" position and go out when switch is turned to "OFF" position. With switch in "ON" position, move test lamp lead to connector white wire. Lamp should light by either depressing "SPEED SET" button or by moving switch to "RESUME" position.

BRAKE SWITCH

Disconnect double connector at switch pigtail and connect a 12 volt source to either terminal, then connect a test lamp from other terminal to ground. Test lamp should light with brake pedal in normal position. Test lamp light should go out when brake pedal is depressed a maximum of $\frac{1}{2}$ " if switch is correctly adjusted.

SERVO UNIT

Locking Coil Test — Turn ignition switch to "ACC" or "ON" position and move slide switch to "ON" position. Momentarily disconnect and connect the double connector at terminals at servo. A clicking sound should be detected in servo. If no clicking sound is heard, replace servo.

Holding Coil & Low Speed Switch Test — Without removing connectors at servo, place one test lamp lead to terminal with black wire (with tracer) and other lead to ground. Block front wheels, raise rear of vehicle, start vehicle and accelerate to 35 MPH. With slide switch in "ON" position, depress and release "SPEED SET" button. Speed should increase above 35 MPH and test lamp light should stay on. Depress brake pedal to disengage system and test lamp light should go out.

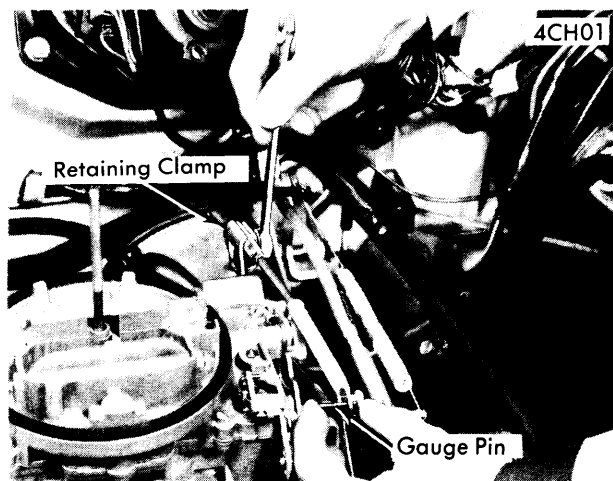
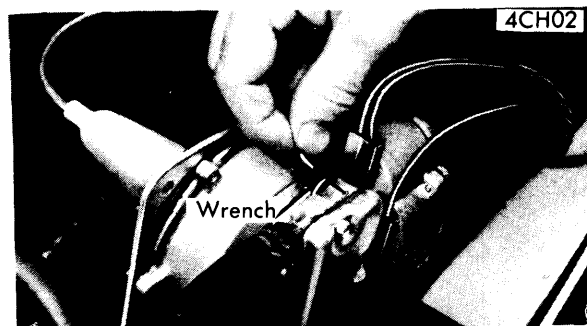
**SERVO THROTTLE CABLE ADJUSTMENT****LOCK-IN SCREW ADJUSTMENT****ADJUSTMENTS****SPEED CONTROL THROTTLE CABLE**

Remove spring clip and insert a $\frac{1}{16}$ " diameter pin between forward end of slot in cable and carburetor linkage pin. With choke in full open position and carburetor at curb idle, pull back on cable (toward dash panel), without moving carburetor linkage, until all free play is removed. Tighten cable clamp bolt to 45 INCH lbs., remove pin and install clip.

BRAKE LIGHT/SPEED CONTROL SWITCH

1) Loosen switch assembly to pedal bracket screws, and slide switch assembly away from pedal blade or push rod. Push in on brake pedal, release and allow pedal to return to natural position. *NOTE* — Do not pull back on brake pedal. Insert a suitable spacer gauge .140" thick on pedal blade or push rod.

2) Slide switch assembly toward pedal blade or push rod until switch contacts spacer gauge with plunger depressed. Tighten switch bracket screws to 75 INCH lbs. Remove spacer and check that switch plunger does not hang up on pedal blade.

SERVO UNIT (LOCK-IN SCREW ADJUSTMENT)

NOTE — Lock-in accuracy will be affected by engine being out of tune, adverse power-to-weight ratio, and improper slack in throttle control cable.

If speed drops more than 2 to 3 MPH when speed control is activated, lock-in adjusting screws should be turned counterclockwise approximately $\frac{1}{4}$ turn for each 1 MPH correction required. If speed increases more than 2 to 3 MPH, turn screw clockwise approximately $\frac{1}{4}$ turn for each 1 MPH correction required. If screw is loose, stake side of servo housing adjacent to screw to ensure a snug fit. *CAUTION* — Screw should never be turned more than 2 turns in either direction or damage to servo unit may occur.