

JEEP

Jeep

REMOVAL & INSTALLATION

DIRECTIONAL SIGNAL

Removal — 1) Disconnect negative battery cable. Remove horn contact trim cover by loosening bottom attaching screws. Disconnect horn wire from switch in steering wheel cavity by pulling quick disconnect connector. Remove steering wheel nut and note alignment of steering wheel to steering shaft index marks for reinstallation.

2) Remove steering wheel using a suitable puller (J-21232-01). Loosen anti-theft cover retaining screws and lift cover from column. *NOTE* — Screws do not need to be completely removed as they are held in the cover by plastic retainers. Use a suitable lock plate compressor tool (J-23653) to depress lock plate and pry small round wire snap ring from steering shaft groove.

3) Remove compressor tool, snap ring, lock plate, directional signal canceling cam, upper bearing preload spring and thrust washer from steering shaft. Place directional signal actuating lever in right turn position and remove lever. Depress hazard warning light switch and remove button by turning in a counterclockwise direction.

4) Remove directional signal wire harness connector block from mounting bracket on right side of lower column. On vehicles equipped with automatic transmission, use a stiff wire to depress lock tab retaining shift quadrant light wire in connector block. Remove directional signal switch retaining screws and pull signal switch and wire harness from column.

Installation — Guide wire harness into position and align signal switch assembly. *NOTE* — Actuating lever pivot must be correctly aligned and seated in upper housing pivot boss before retaining screws are installed. Install retaining screws to switch assembly. Install lever and check for correct operation. Position thrust washer, spring and canceling cam on upper end of steering shaft. Align steering shaft and lock plate splines, then install lock plate while ensuring that canceling cam shaft protrudes through dogleg opening in lock plate. Install snap ring and anti-theft cover. Install hazard warning light button, steering wheel (aligning index marks) and steering wheel nut. Connect horn wire and battery cable. Install horn contact trim cover.

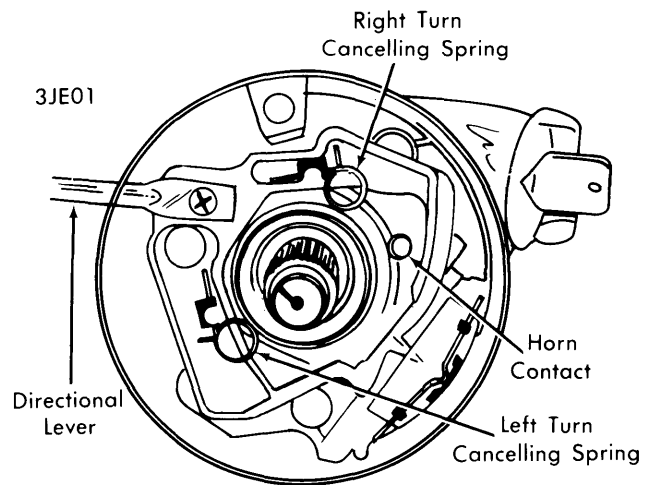

DIRECTIONAL SIGNAL SWITCH