

## CHRYSLER CORP. GEAR REDUCTION

Dodge  
Plymouth

### DESCRIPTION

The starter motor consists of four series parallel fields, four brushes and a solenoid shifted overrunning clutch. The starter has a 3.5 to 1 reduction gear set built into starter assembly, which is housed in diecasted aluminum. The starter system consists of two separate circuits: the supply circuit which provides the heavy current to the motor, and the control circuit which actuates the solenoid.

### TESTING

#### STARTER CONTROLS

*NOTE* — Test solenoid and relay in order as described. Before performing any test, disconnect coil wire from distributor cap and secure to a good ground to prevent engine from starting.

**Starter Solenoid** — Connect a heavy jumper wire on starter relay between battery and solenoid terminals. If engine cranks, solenoid is good, proceed to starter relay test. If engine does not crank, check wiring and connectors from relay to starter for loose or corroded connections. Repeat test and if starter still fails to crank, starter must be removed for repairs.

**Starter Relay** — Position automatic transmission gear selector in "N" or "P" position and manual transmission in neutral. Connect a jumper wire on starter relay between battery and ignition terminals. If engine cranks, the starter relay is good. If engine does not crank, connect a second jumper wire to starter relay ground terminal and a good ground. If engine still does not crank, replace starter relay. If engine does crank, relay is functioning, but transmission linkage is out of adjustment (automatic transmission) or neutral safety switch is defective (automatic transmission) or there is a poor ground between relay housing and its mounting surface.

#### CRANKING CIRCUIT TESTS

Make the following tests with the engine cranking and all terminals connected. Connect a voltmeter at the following locations: Positive lead to battery positive post and negative lead to battery terminal on starter; positive lead to starter housing and negative lead to negative post on battery; positive lead to engine block and negative lead to battery ground cable. Each of these three connections should show a voltmeter reading of .2 volts or less. If reading exceeds .2 volts, clean or repair cables and connections in circuit. Connect a voltmeter at the following locations: Positive lead to battery positive post and negative lead to cable clamp; positive lead to battery negative post and negative lead to cable clamp. If reading is other than zero on voltmeter, clean or repair cables and connections in circuit.

#### AMPERAGE DRAW TEST

*NOTE* — Engine should be up to operating temperature before performing this test. Heavy oil or a tight engine will increase starter draw amperage.

1) Connect a suitable battery-starter tester leads to battery. Turn variable resistor control knob to off or zero position and voltmeter to read battery voltage. Crank engine long enough to read cranking voltage on voltmeter. **CAUTION** — Do not crank engine excessively or starter may overheat.

2) Without cranking engine, turn variable resistor control knob on tester until voltmeter reads cranking voltage of previous test. With same voltage reading, amperage reading will be equivalent to starter current draw (see specifications).

#### SOLENOID WINDINGS

Test solenoid windings with suitable test equipment, using a 6 volt battery for power source to prevent starter motor from energizing. Readings should be within specifications.

#### NO LOAD TEST (ON BENCH)

Connect a test ammeter and carbon pile rheostat in series with battery positive post and starter terminal. Connect a voltmeter across starter. Rotate carbon pile to full resistance position. Connect battery cable from battery negative post to starter frame. Adjust rheostat until battery voltage shown on voltmeter reads 11 volts. Amperage draw should be as shown in specifications.

#### LOCKED RESISTANCE TEST

Mount starter in test bench. Follow test equipment manufacturer's instructions. With battery voltage adjusted to 4 volts, amperage draw should be as shown in specifications.

#### Starter Specifications

Application	Amps.
Amperage Draw Test	
225" & 318" .....	165-180
360" & 440" .....	180-200
Solenoid Winding Test ( $\bar{a}$ 77°F)	
Pull-In Circuit .....	13-15
Hold-In Circuit .....	8-9
No Load Test (3700 RPM Min.) .....	90
Locked Resistance Test .....	475-550

### OVERHAUL

#### DISASSEMBLY

1) Remove through bolts and end head assembly. By pulling outwards, remove armature from gear housing and field frame assembly. Carefully pull field frame assembly from gear housing just far enough to expose terminal screw. Remove terminal screw, then completely remove field frame assembly.

2) Remove nuts and separate solenoid and brush plate assembly from gear housing. Remove nut, steel washer and insulating washer from solenoid terminal. Unwind solenoid lead wire from brush terminal. Remove nuts attaching solenoid and brush holder plate assembly-to-gear housing and remove solenoid and brush holder plate assembly. Remove screws attaching solenoid to brush plate.

3) On brush plate, remove nut from battery terminal, then remove terminal. From solenoid, remove solenoid contact and plunger assembly. Remove return spring from inside of solenoid moving core. Remove dust cover from gear housing.

4) Release retainer clip that positions driven gear on pinion shaft. **CAUTION** — Retainer is under tension. Place cloth over assembly to catch it as it flies off. Remove pinion shaft "C" clip. Push shaft toward rear of housing and remove retainer ring

## CHRYSLER CORP. GEAR REDUCTION (Cont.)

and thrust washers, clutch and pinion assembly, and the two shift fork nylon actuators as an assembly. Remove driven gear and friction washer. Pull shifting fork forward and remove solenoid moving core. Remove shifting fork retainer pin, then shifting fork assembly.

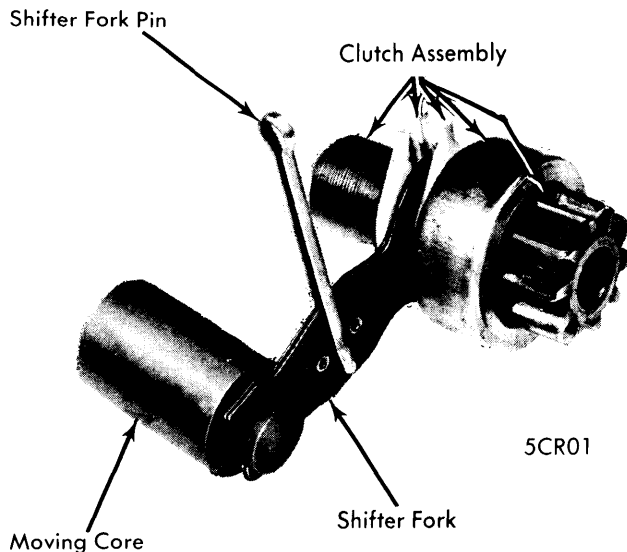

## SHIFT FORK &amp; CLUTCH ASSEMBLY

## PARTS REPLACEMENT &amp; TESTING

**Brushes & Springs** – Replace if oil soaked or worn more than 1/2-length of new brushes. When resoldering shunt field and solenoid lead, use high temperature solder and resin flux. **NOTE** – Do not use acid core solder. Measure spring tension with spring scale hooked under spring near end, pull on line parallel to edge of brush and note reading just as spring end leaves brush. Replace if tension not within specifications.

## Application

All ..... Tension 32-36 ozs.

**Armature** – Check for shorted armature coils in a growler. Check for grounded coils by touching one test light probe to armature shaft and other probe to each commutator bar. Lamp should not light. If lamp lights, armature coils are grounded and armature should be replaced. Commutator should be smooth and clean, runout must not exceed .004" If runout excessive, reface in a lathe removing only sufficient material to provide smooth even surface.

**Field Coil Assembly** – With field frame removed from starter, drill out rivet attaching field coil lead and shunt coil lead to frame, then insulate leads from frame. Test for ground with 110V test lamp by touching one probe to field coil lead and other probe to field frame. Lamp should not light, if lamp lights, field coils are grounded. Replace field coils and field frame as an assembly.

**Starter Shaft Bushings** – Inspect shaft bearing surfaces for wear, check bushing wear by inserting shaft and checking sideplay. Replace end head if bushing worn (furnished as an assembly). Replace other bushings with Tool C-3944 and adapters. Service bushings are pre-sized and do not require burnishing or reaming.

**Starter Clutch Unit** – **CAUTION** – Do not immerse in cleaning solvent (pre-lubricated and lubricant will be washed out). Pinion should rotate smoothly in one direction (not necessarily easily) and should not rotate in opposite direction. If not functioning properly, or if pinion worn, chipped or burred, replace assembly.

## CLEANING

Do not immerse parts in cleaning solvent. Clutch outer housing and pinion gear may be cleaned with a cloth moistened with cleaning solvent then wiped dry. Clean all corrosion from solenoid assembly and inside of solenoid housing (these are part of solenoid hold-in ground circuit and must be clean). Clean terminal contacts and contactor with crocus cloth.

## REASSEMBLY

- 1) Make sure shift fork plates have approximately 1/16" side movement, lubricate sparingly between plates with SAE 10 engine oil. Position shift fork in housing bending one tip of pin at 15° angle away from housing. **NOTE** – Fork and pin must operate freely. Install solenoid moving core and engage shifting fork.
- 2) Start pinion shaft into drive housing, install friction washer and drive gear, clutch and pinion assembly, thrust washer, retaining ring and thrust washer. Make sure shift fork engages clutch actuators properly. **NOTE** – Friction washer must be positioned on shoulder of splines of pinion shaft before driven gear is positioned. Install driven gear retainer clip, pinion shaft "C" clip, and starter solenoid return spring into bore of movable core.
- 3) Install solenoid contact plunger assembly into solenoid and reform double wires to allow for proper entry of terminal stud into brush holder with double wires curved around contactor. **CAUTION** – Contactor must not touch wires when solenoid is energized after assembly. Assemble battery terminal stud in brush holder. Position seal on brush holder plate.
- 4) Start solenoid lead wire through hole in brush holder, install solenoid stud, insulating washer, flat washer and nut. Wrap lead wire tightly around brush terminal post, solder with high temperature resin core solder and resin flux. Install brush holder to solenoid attaching screws. Enter solenoid coil and brush plate assembly into starter gear housing, install and tighten attaching nuts.
- 5) Install armature thrust washer in brushes with brushes resting on washer tabs (washer will hold brushes out and facilitate armature installation). Install brush terminal screw. Position field frame in correct position on gear housing and install armature in field frame and gear housing. Carefully engage splines of shaft with reduction gear by rotating armature slightly. Install thrust washer on armature shaft. Position starter end head assembly and tighten through bolts securely.

## CHRYSLER CORP. GEAR REDUCTION (Cont.)

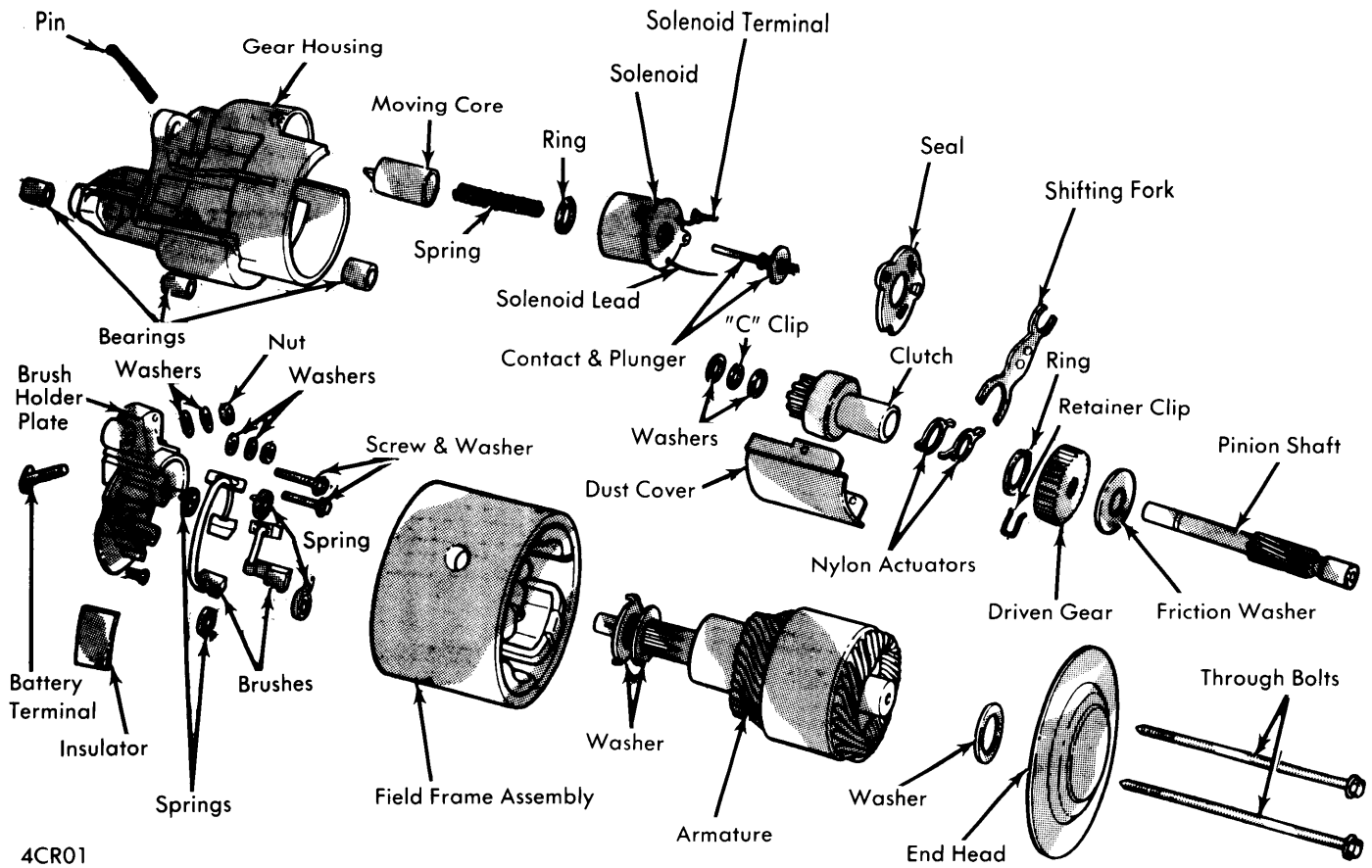

4CR01

## CHRYSLER CORP. REDUCTION GEAR STARTER