

MOTORCRAFT TRANSISTORIZED REGULATOR

Ford

DESCRIPTION

Regulator unit regulates alternator field current through the use of transistors and diodes rather than by a vibrating armature relay as the electro-mechanical regulator does. This unit is used on all 70 and 90 ampere alternator units and may be identified by the part number D4TZ-10316-A.

ADJUSTMENT

Voltage Limiter Adjustment — Adjustment is made with regulator at normal operating temperature. Remove top regulator mounting screws and remove cover from regulator. Use a fiber rod as a screwdriver to make adjustments. Turn clockwise to increase voltage and counterclockwise to decrease voltage.

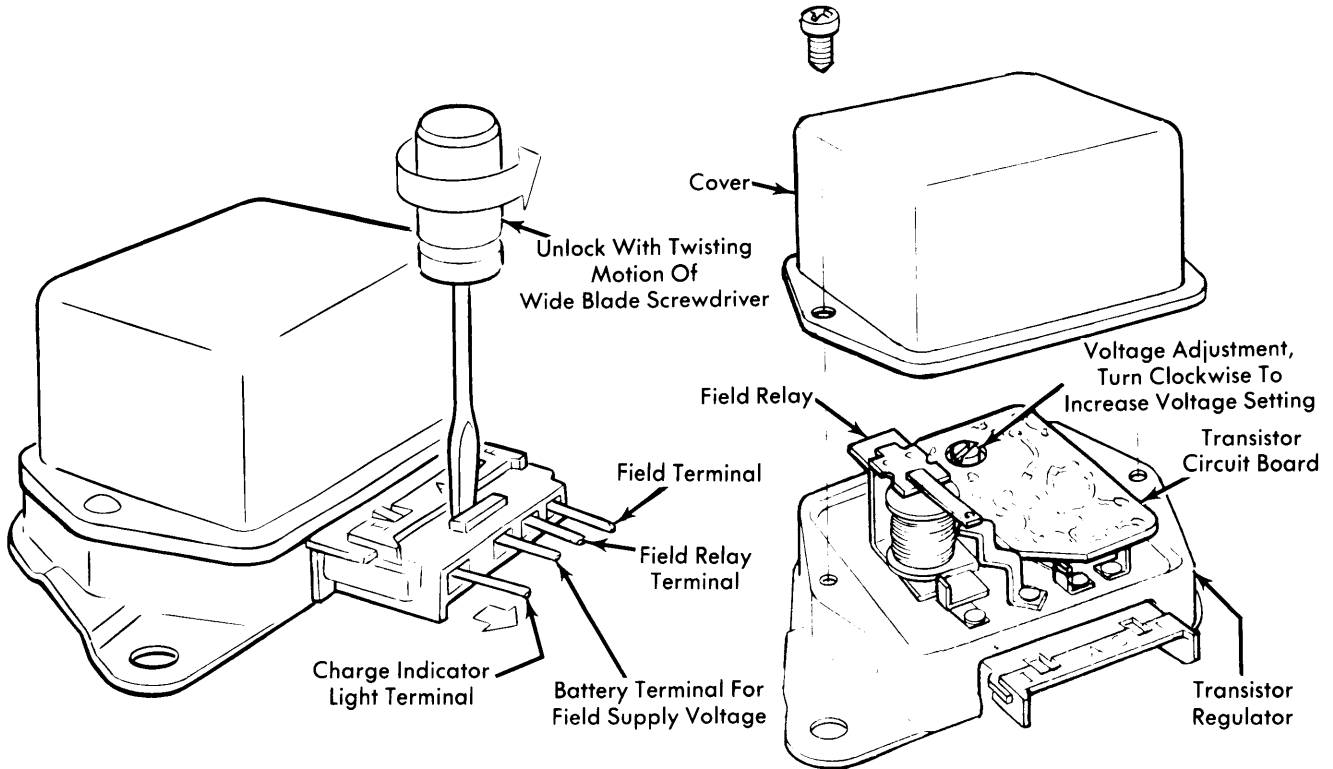

5FO01

TRANSISTORIZED ALTERNATOR REGULATOR