

CHRYSLER CORP. ALTERNATORS

Dodge
Plymouth

DESCRIPTION

Alternator is a conventional three-phase, self-rectifying type. Main components are two end housings, stator, rotor and rectifiers. The rotor consists of a field coil encased between two six-fingered overlapping sections which are the pole pieces and produces a 12 pole magnetic field. Ends of the field coil are connected to the field windings through brushes and slip rings. Pre-lubricated bearings provide support of rotor shaft at the end housings. Three silicone diode rectifiers having negative polarity are pressed into the end housing and three similar diodes having positive polarity are pressed into a die-cast aluminum sink. Alternator output is controlled by a voltage regulator.

CAUTION — Reversed polarity or excessive voltage will result in extensive damage to alternator system. Do not reverse battery leads upon battery installation and both battery cables must be disconnected during charging of battery with a "Fast Charger". Do not use a "Fast Charger" to provide starting voltage.

SPECIFICATIONS

| Alternator ^① | Volts | ② Amps. |
|-------------------------|-------|---------|
| 3755404 | 15 | 41 |
| 3755406 | 15 | 50 |
| 3755407 | 15 | 60 |
| 3755411 | 15 | 50 |
| 3755413 | 15 | 60 |
| 3755441 | 15 | 41 |
| 3755444 | 15 | 50 |
| 3755447 | 15 | 60 |

- ① — Alternator stamped number.
② — Checked at 1250 RPM. Specification is ± 3 amperes.

Rotation — Clockwise at drive end.

Field Coil Draw — 2.5-3.7 amperes at 12 volts while turning rotor manually.

Capacitor Capacity — .50 mfd. $\pm 20\%$.

TESTING

NOTE — Following tests are without the use of special equipment. If special test equipment is used, follow directions of equipment manufacturer. Make all tests with battery fully charged and engine at normal operating temperature.

CHARGING CIRCUIT RESISTANCE

NOTE — Before making test connections, disconnect battery ground cable at battery negative post to avoid accidental shorting of charging or field circuits.

1) Disconnect "BAT" lead at alternator and connect a 0-75 ampere scale D.C. ammeter in series between alternator "BAT" terminal and disconnected lead. Connect positive lead

of a voltmeter to disconnected "BAT" lead and connect negative voltmeter lead to battery positive terminal. Disconnect field lead from alternator, then connect a jumper lead from alternator field terminal to ground. Connect a tachometer and then connect battery ground cable. Connect a variable carbon pile to battery terminals.

2) Start engine and operate at idle. **CAUTION** — To avoid damage, reduce engine speed to idle immediately after starting. Adjust engine speed and carbon pile to obtain 20 amperes flowing in circuit. Voltmeter reading should not exceed .7 volts. If a higher voltage drop is indicated, inspect, clean and tighten all connections in charging circuit. **NOTE** — If necessary, test voltage drop at each connection to locate connection with excessive resistance.

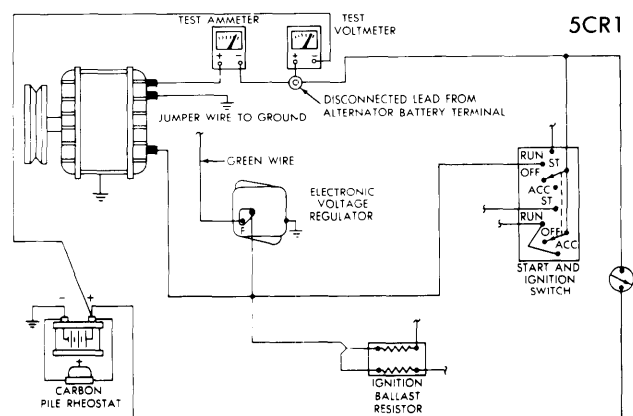

CHARGING CIRCUIT RESISTANCE TEST

CURRENT OUTPUT

1) Connect test equipment the same as for Charging Circuit Resistance test, move negative lead of voltmeter to a good ground and then move the positive lead of voltmeter to "BAT" terminal of alternator. Start engine and operate at idle. **CAUTION** — To avoid damage, reduce engine speed to idle immediately after starting.

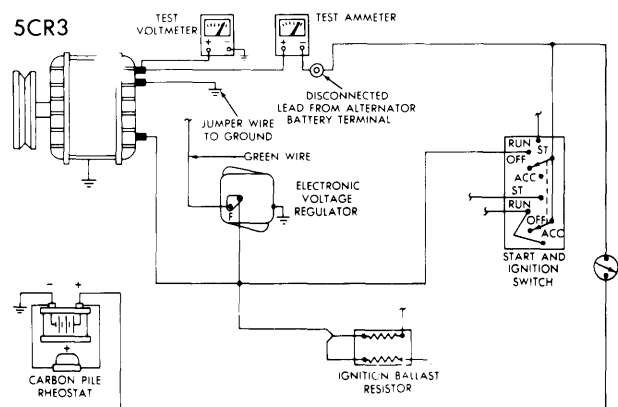

CURRENT OUTPUT TEST

2) Adjust engine speed and carbon pile until a speed of 1250 RPM and a voltmeter reading of 15 volts is obtained. **CAUTION** — Increases in engine speed should not be large enough to allow voltage to exceed 16 volts. Observe ammeter, current output should be within specifications.

CHRYSLER CORP. ALTERNATORS (Cont.)

FIELD COIL DRAW

Connect a wire between one field terminal of alternator and positive terminal of a fully charged battery. Connect test ammeter positive lead to the other field terminal of alternator and negative lead to battery negative terminal. Slowly rotate alternator rotor by hand. Observe ammeter reading. Field coil draw should be within specifications. A low coil draw is an indication of high resistance in field coil circuit (brushes, slip rings or rotor coil). A higher coil draw indicates possible shorted rotor coil or grounded rotor. No reading indicates an open rotor or defective brushes.

RECTIFIER (DIODE) TEST

NOTE — Rectifiers may be tested with a test lamp or with Tester C-3829 as follows:

Test Lamp Method — With rectifier end shield and stator assembly separated from alternator proceed as follows: Test rectifiers (diodes) with a 12 volt battery and a test lamp, (No. 67 bulb, 4 candlepower) by connecting one side of test lamp to negative battery post and other side to positive battery post. Contact heat sink of rectifier with one test probe, and the other test probe to strap on top of rectifier. Now reverse probes, if lamp lights in one direction but does not light in other direction, rectifier is good. If lamp lights in both directions, rectifier is shorted. If lamp does not light in either direction, rectifier is open.

Tool C-3829 Method — Remove alternator brushes and through bolts. Separate rectifier end housing and stator from drive end housing and rotor. Test rectifiers as follows:

1) Check positive rectifiers with alternator on an insulated surface. Connect test lead clip to alternator "BAT" output terminal and plug tool into 110 volt A.C. power supply. Touch exposed bare metal connections of each positive case rectifier with test probe. Reading for satisfactory rectifiers will be 1.75 amperes or more and should be approximately the same for each rectifier. When two rectifiers are good and one is shorted, reading taken at good rectifiers will be low and reading at shorted rectifier will be zero. Disconnect lead to rectifier reading zero and retest. Reading of good rectifiers will now be within satisfactory range. When one rectifier is open it will read approximately 1.0 ampere, and two good rectifiers will read within satisfactory range.

2) To check negative rectifiers, connect test lead clip to rectifier end housing. Touch exposed connection of each negative case rectifier with test probe. *CAUTION* — Do not break sealing around rectifier lead wire or on inner end of rectifier as this will accelerate corrosion. Test specifications and results will be approximately the same as for positive case rectifiers, except meter will read on opposite side of scale.

STATOR TEST

Separate stator from both end shields. Press test probe firmly onto any pin on stator frame. Be sure varnish has been removed so the pin is bare. Press test probe firmly to each of the three phase lead terminals one at a time. If lamp lights, stator lead is grounded. Now press test probe firmly on one phase control lead and contact each of the other two stator leads. Test lamp should light when probe contacts each of the terminals. If lamp does not light, stator is open. Install a new stator if it is open or grounded.

ROTOR TEST

Test rotor for grounded, open or shorted field coils using an ohmmeter. Test for grounds by connecting an ohmmeter between each slip ring to the rotor shaft. No continuity should exist or rotor is grounded. Check for an open field by connecting an ohmmeter across slip rings. A reading of 3-4 ohms indicates normal resistance. Readings above 6.5 ohms indicate high resistance and rotor replacement may be necessary. If reading is 3 ohms or less, field coil is shorted.

OVERHAUL

DISASSEMBLY

1) Remove brush screws, insulating washers, and lift brush assemblies from end shield. *NOTE* — Stator is laminated, do not burr stator or end shield. Remove through bolts and pry between stator and drive end shield with blade of screwdriver. Carefully separate drive end shield, pulley and rotor assembly away from stator and rectifier shield assembly.

2) Remove rectifier and heat sink assembly as follows: Loosen four screws securing negative rectifier and heat sink assembly to end shield. Remove two outer screws and lift assembly from end shield. Remove two nuts and washers securing positive rectifier and heat sink assembly to insulated terminals in rectifier end shield. Remove screw grounding capacitor to case and lift out insulated washer, capacitor and positive rectifier with heat sink assembly.

3) Pulley is an interference fit on rotor shaft. Remove pulley with suitable puller (C-4068) and pry drive end bearing retainer from end shield with a screwdriver. Support end shield and tap rotor shaft with a plastic hammer to separate rotor from end shield. Remove drive end bearing using suitable puller (C-4068). If necessary to remove rectifier end frame needle bearing, protect end shield by supporting it with suitable tool (C-3925). Press bearing out using suitable tool (C-3770A).

SLIP RING REPLACEMENT

Slip rings are not serviced as a separate item. They are serviced with the rotor assembly.

REASSEMBLY

1) Place grease retainer on rotor shaft and press retainer onto shaft until suitable tool (C-3921) bottoms on shaft. Position rectifier end shield bearing on base of suitable tool (C-4201) and alternator end shield on top of bearing so it is properly aligned. With top part of tool placed on end shield, press into place until it bottoms.

2) Insert drive end bearing in drive end shield and install bearing retainer plate to hold bearing in place. Position bearing and drive end shield on rotor shaft, and while supporting base of rotor shaft, press bearing end shield into position on rotor shaft with an arbor press and suitable adapter (C-3858). *CAUTION* — Make sure bearing is installed squarely.

Alternators

CHRYSLER CORP. ALTERNATORS (Cont.)

3) Install pulley on rotor shaft. Shaft of rotor must be supported so all pressing force is on pulley hub and rotor shaft and not on bearings. Do not hammer pulley on.

4) If removed, install output terminal stud and insulator through end shield. Be sure mica insulators are in place and undamaged. Install positive heat sink assembly over studs and then guide rectifier straps over studs on terminal block. Install capacitor over end stud and install shoulder insulator. Ground bracket to end shield with metal screw, then install and tighten positive heat sink nut and lock washer assemblies.

5) Slide negative rectifier and heat sink assembly into place, position straps and install screws. Position stator over rectifier

end shield and install winding terminals on terminal block and press stator pins into each end shield. Install winding terminals nuts. Route leads so they cannot contact rotor or sharp edges of negative heat sink. Position rotor and drive end shield over stator and rectifier end shield and install through bolts. Compress both ends manually and tighten through bolts evenly to 40-60 INCH lbs.

6) Install field brushes in insulated holders and position vertical and horizontal field brushes in proper location in rectifier end shield. Place an insulating washer on each field brush terminal before installing lock washers and screws. Be sure that brushes are not grounded. Rotate pulley slowly by hand to be sure rotor fan blades do not hit stator winding leads.

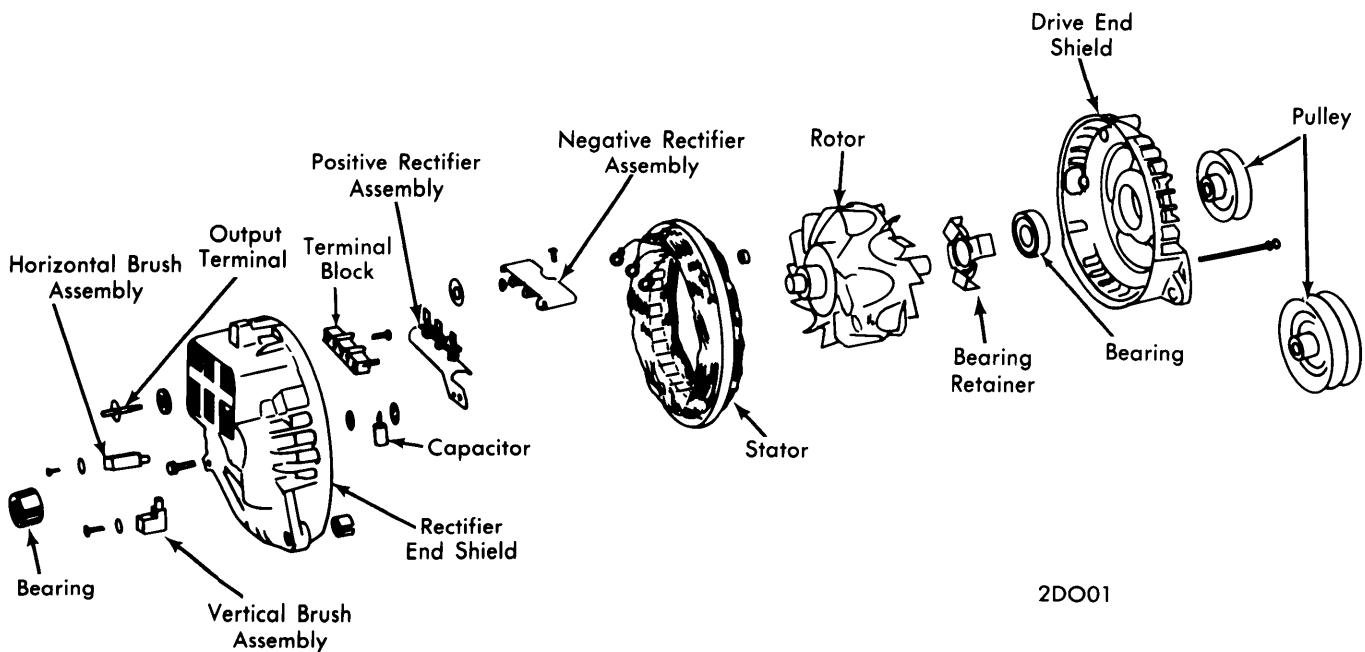

CHRYSLER CORP. ALTERNATOR