

DODGE SPEED CONTROL

Dodge (1970-74)

DESCRIPTION

System is electrically actuated and vacuum operated. Turn signal lever on steering column incorporates a control ring which when rotated, turns the system "OFF", "ON", or "RESUME SPEED". A speed set button is located in the end of turn signal lever. System is designed to operate above 30 MPH.

OPERATION

Engaging System – Rotate control ring to "ON" position, attain desired speed, then momentarily depress and release speed set button. Remove foot from accelerator and speed will be maintained at selected level. Turning control ring from "OFF" to "ON" while car is in motion establishes memory without system engagement at that speed.

Disengaging System – Normal brake application or a soft tap on brake pedal will disengage control unit without erasing speed memory. Fully rotating control ring to "OFF" or turning ignition off also disengages system and in addition erases speed memory.

Resuming Speed – Momentarily rotate control ring fully in resume direction. Vehicle will resume to previously memorized speed.

Changing Speed Setting – To increase speed, accelerate to desired speed and momentarily depress and release speed set button. When unit is engaged, tapping button will increase speed in small amounts. To decrease speed, tap brake pedal lightly to disengage system. When desired speed has been obtained, depress and release speed set button. Decrease in speed can also be obtained by holding set button depressed until desired speed is attained. Releasing button engages system at that speed.

Speed
Control
Switch

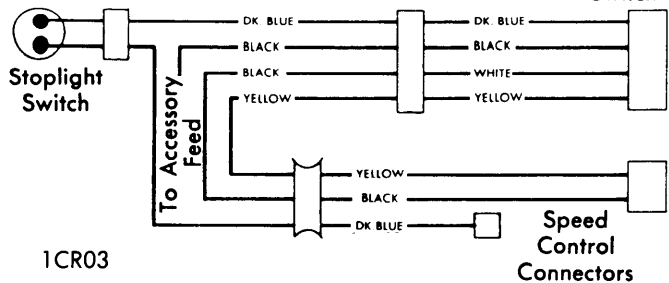

SPEED CONTROL WIRING DIAGRAM

TROUBLE SHOOTING

NO SPEED CONTROL WHEN BUTTON PRESSED

Control ring in "OFF" position. Fuse blown. Faulty electrical circuit. Vacuum leak. Speed control throttle cable disconnected. Insufficient brake switch clearance.

NO RESUME WHEN CONTROL RING IS ROTATED

Faulty electrical circuit. Insufficient rotation of control ring.

NO AUTO. RELEASE WITH PEDAL DEPRESSED

Speed control cable kinked or damaged. Improper adjustment of brake switch. Faulty electrical circuit.

SPEED CONTROL ENGAGES WITHOUT ACTUATING SPEED SET BUTTON

Faulty electrical circuit. Faulty holding coil valve in servo unit.

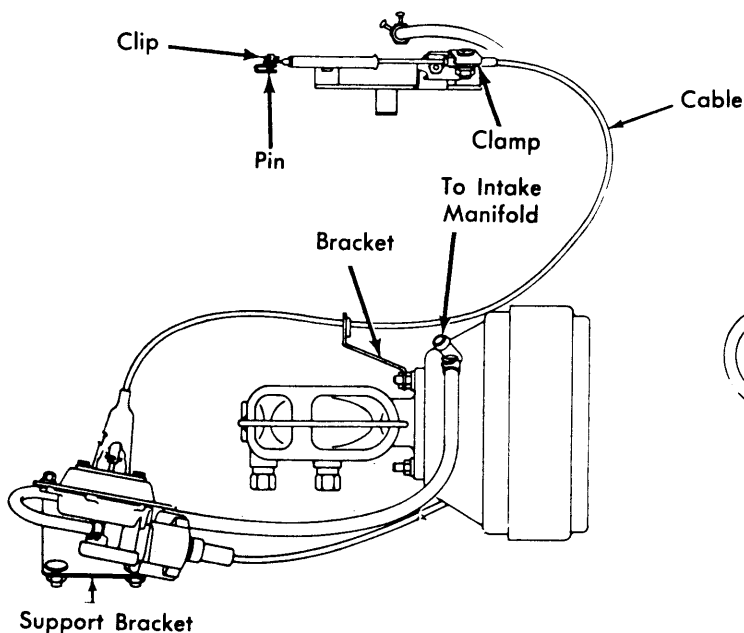

SPEED CONTROL ASSEMBLY (TYPICAL)

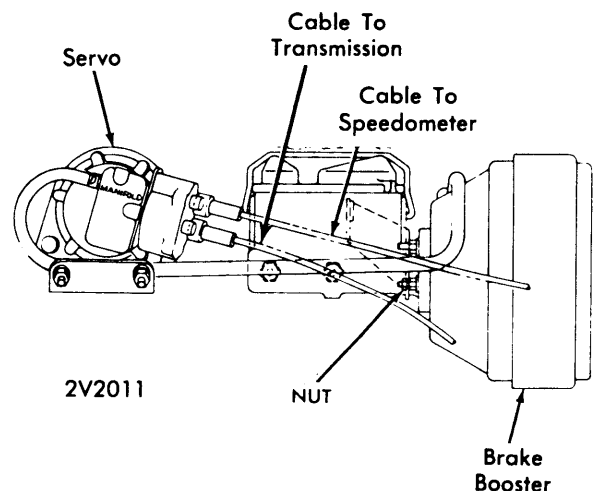

DODGE SPEED CONTROL (Cont.)

CARBURETOR DOES NOT RETURN TO NORMAL IDLE

Speed control cable kinked or damaged. Speed control cable improperly adjusted. Standard throttle linkage faulty.

SPEEDOMETER NOISE, EXCESSIVE NEEDLE FLUTTER OR ERRATIC SERVO LOCK-IN PERFORMANCE

Speedometer cable loose at speedometer head, transmission or speed control servo. Speedometer upper or lower cable kinked or damaged.

SPEED SETTING AFTER LOCK-IN TOO HIGH OR TOO LOW

Improper speed control throttle cable adjustment. Vacuum leak. Improper speed control servo lock-in adjustment.

UNIT DISENGAGES ON ROUGH ROAD

Insufficient brake switch clearance.

RESUME SPEED POSSIBLE BELOW 20 MPH

Faulty low speed inhibit switch in servo unit. Faulty electrical circuit.

SPEED CONTROL ENGAGES WHEN ENGINE STARTED OR DOES NOT DISENGAGE WITH PEDAL DEPRESSED

Faulty electrical circuit.

TESTING

Speed Control Switch — Disconnect 4-wire connector at steering column. Connect a 12 volt positive source to black wire terminal in speed control harness connector (male). With switch in "ON" position, connect a test lamp between connector yellow wire and ground. Lamp should light and then go out when speed set button is depressed. Move test lamp lead to connector blue wire. Lamp should light with switch in "ON" position and go out when switch is turned to "OFF" position. With switch in "ON" position, move test lamp lead to connector white wire. Lamp should light by either depressing speed set button or by moving switch to "RESUME" position.

Brake Switch — Disconnect double connector at switch pigtail and connect a 12 volt source to either terminal, then connect a test lamp from other terminal to ground. Lamp should light when pedal is depressed to a maximum of $\frac{1}{2}$ " after proper adjustment. See *Brake Switch Adjustment*.

Servo Unit — Turn ignition switch to "ACCESSORY" or "ON" position. Move control ring to "ON" position. Momentarily disconnecting and connecting double connector at servo terminals should produce a clicking sound in servo. If no clicking sound heard, replace servo. Without removing either connector at servo, place a test lamp probe to white wire terminal of servo. Place other probe to a good ground. Block front wheels, raise rear wheels and drive rear wheels to 35 MPH. With both ignition switch and speed control switches in "ON" position, depress and release speed set button. Speed should increase above 35 MPH and test lamp should remain on until brake pedal is depressed.

ADJUSTMENTS

Speed Control Throttle Cable — Insert a $\frac{1}{16}$ " diameter pin between forward end of slot in cable and carburetor linkage pin. With choke in full open position and carburetor at curb idle, pull back on cable (toward dash panel) without moving carburetor linkage until all free play is removed. Tighten cable clamp bolt to 45 INCH lbs. and remove $\frac{1}{16}$ " pin.

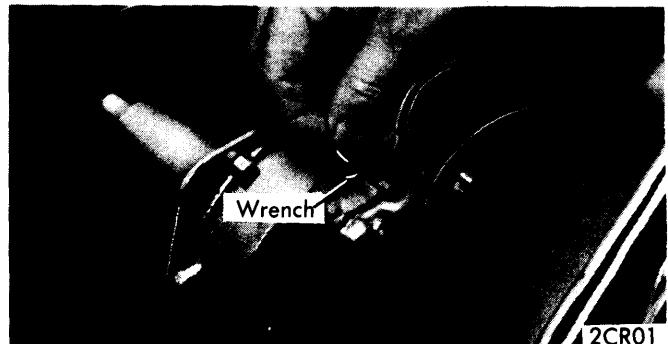

LOCK-IN SCREW ADJUSTMENT

Brake Switch — Loosen switch bracket. Clearance should be .140". Insert proper spacer gauge between brake push rod and switch with pedal in free position. Push switch bracket assembly toward brake push rod until plunger is fully depressed and switch body contacts spacer. Retighten bracket to 100 INCH lbs. and remove spacer.

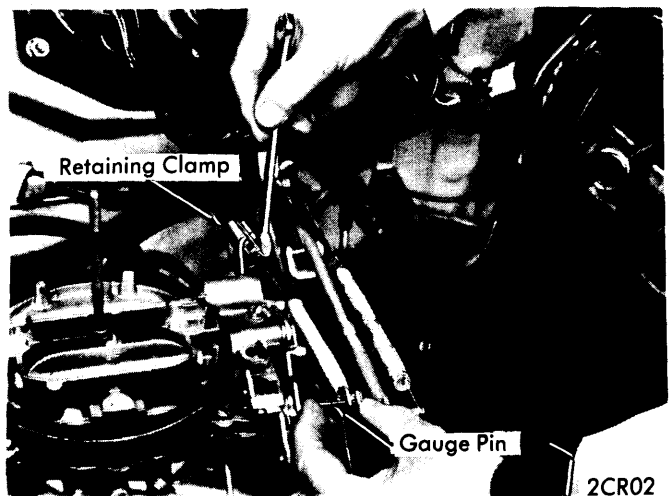

SERVO THROTTLE CABLE ADJUSTMENT

Servo Unit — *NOTE* — Lock-in accuracy will be affected by engine out of tune, adverse power-to-weight ratio, and improper slack in throttle control cable. If speed drops more than 2-3 MPH when speed control, is activated, lock-in adjusting screw should be turned counterclockwise approximately $\frac{1}{4}$ turn for each 1 MPH correction required. If speed increases more than 2-3 MPH, turn screw clockwise. If screw is loose, stake side of servo housing adjacent to screw to insure a snug fit. *CAUTION* — Screw should never be turned more than two turns in either direction or damage to unit may occur.