

Wiper/Washer Systems

PORSCHE

DESCRIPTION

Porsche 911SC and 928 models have a 3-speed wiper motor. The 924 models use a 2-speed motor. All models have an intermittent cycle. A rear wiper may be installed on all models. A steering column lever is used to control the main wiper system.

A dashboard-mounted switch is used to vary the intermittent cycle (not used on 924). All models may be equipped with headlight washer. On 928, a special tank of concentrated washer fluid is provided to ensure good windshield cleaning.

NOTE: Information on 944 models not available from manufacturer.

OPERATION

FRONT WIPERS

Moving the steering column lever upward selects the wiper speed. Moving the lever downward operates the intermittent feature on 924 and 928. A switch near the clock selects intermittent on the 911SC. The interval on the 928 can be varied by rotating a thumbwheel under the right side of the instrument cluster.

REAR WIPERS

The rear wiper on 924, 924 Turbo and 928 is controlled by a console switch. On 911SC, the switch is on the cluster. No rear washer is used. Be sure window glass is wet to prevent scratches.

WINDSHIELD WASHER

The washer sprays when the wiper lever is pulled toward the steering wheel. 928 models also have a special container of solution which ensures good cleaning. This washer is operated by a button under the right side of the cluster (by the intermittent adjustment thumbwheel).

HEADLIGHT WASHER

All models may have a headlight washer. This unit sprays fluid under high pressure directly onto the headlights. It operates only when the headlights are raised (924 and 928) and on. It uses the windshield washer reservoir.

A separate pump is provided, which is operated by the wiper lever on 928 and a special button on 911SC and 924. The button is on the instrument cluster on 911SC, and on the console for 924 models.

REMOVAL & INSTALLATION

FRONT WIPER MOTOR

Removal (All Models)

Remove motor cover (if equipped). Remove crank arm nut and unplug wiring. Remove motor bolts. If necessary, loosen motor bracket bolts to slip motor out.

Installation

Install motor on bracket and connect wiring. Let motor run and return to park position, then install crank arm so wiper arms are parked at bottom of windshield. Replace motor cover.

Fig. 1: 911SC Wiper System Wiring Diagram

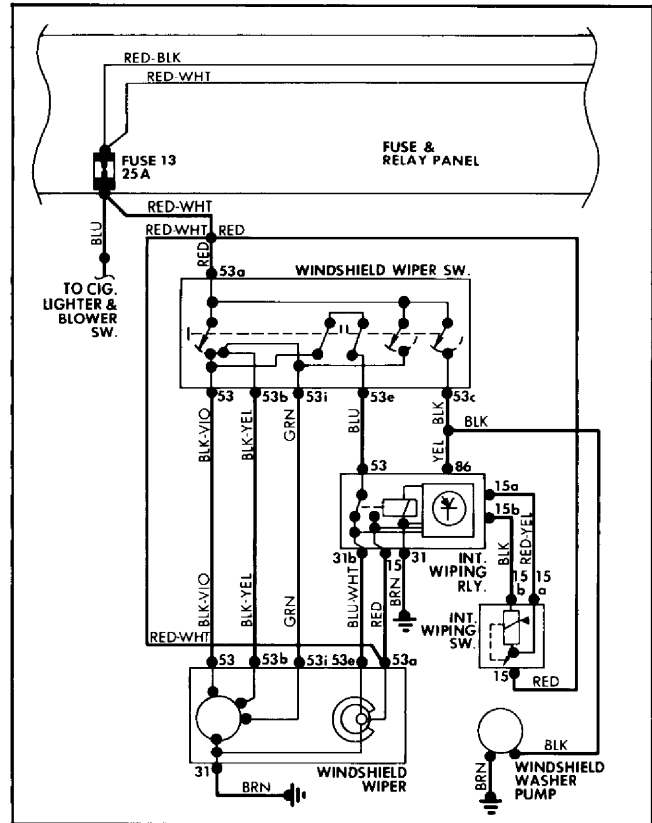
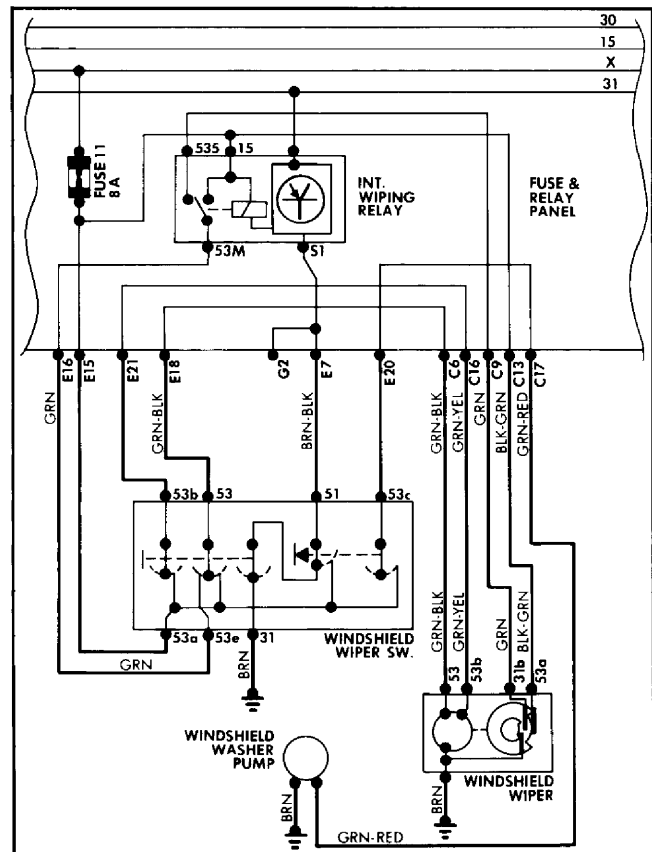

Fig. 2: 924 & 924 Turbo Wiper System Wiring Diagram



Wiper/Washer Systems

PORSCHE (Cont.)

Fig. 3: 928 Wiper System Wiring Diagram

