

Wiper/Washer Systems

DATSUN/NISSAN

200SX, 210, 280ZX, 310, Maxima, Pickup, Sentra & Stanza

correctly. Some models have a circuit breaker (mounted externally) to protect the wiper motor.

DESCRIPTION & OPERATION

All models are equipped with either 2-speed or intermittent wipers. An optional variable intermittent wiper system may also be used. In the variable system, wiper operation may be varied from 4 to 12 seconds.

Hatchback and station wagon models have a rear wiper/washer system, operated by a dashboard mounted switch. All front wiper/washer systems are operated by a steering column lever.

WIPER MOTOR

All wiper motors include an integral park switch inside the motor housing. The motor cover can be removed and the switch adjusted if wipers do not park

INTERMITTENT AMPLIFIER

All models except Maxima use an intermittent amplifier to control the delayed wiper cycle. The amplifier is a solid-state unit which interrupts current flow to the motor. The time delay is either fixed or adjustable with a knob at the end of the wiper stalk.

All Maxima models have a Time Control Unit which controls the delayed wiper cycle. This unit also operates the clock, turn and hazard flashers, seat belt chimes and other circuits.

WASHER

All models have windshield washer systems. A separate pump is used for the rear washer. A common reservoir is used for both washer systems.

DATSUN/NISSAN WIPER SYSTEM COMPONENT LOCATIONS

Model & Component	Connector	Location
200SX Intermittent Amplifier Ignition/Accessory Relay Circuit Breaker Rear Washer Motor	8-Pin 6-Pin & 1-Pin 2-Wire 2-Pin	Rear of relay bracket at right front corner engine compartment Right kick panel Wiper motor connector at cowl Right front shock tower
210 Intermittent Amplifier Rear Washer Motor	6-pin 2-Pin	Brake pedal bracket Behind right front shock tower
280ZX Intermittent Amplifier Accessory Relay Rear Washer Motor	6-Pin 5-Pin 2-Wire	Brake Pedal Bracket Right kick panel, top rear Left front shock tower
310 Intermittent Amplifier	7-Pin	Front of relay bracket at right front corner engine compartment
Maxima Time Control Unit Wiper Relay Accessory Relay	8-Pin & 11-Pin 5-Pin 4-Pin	Right kick panel at top Rear outside corner of relay bracket at right front corner engine compartment Front outside corner of relay bracket
Pickup Intermittent Amplifier	5-Pin	Steering column bracket
Sentra Intermittent Amplifier	7-Pin 6-Pin	Firewall behind left front shock tower Firewall behind left front shock tower
Stanza Intermittent Amplifier Circuit Breaker	7-Pin	Firewall behind left front shock tower Top of wiper motor plug connector

DATSUN/NISSAN (Cont.)

FRONT WIPER MOTOR TESTING

Model	Continuity (Motor Off)	Slow Speed Connections	High Speed Connections	Park Switch (On-Off with Motor Running)
200SX	B & L B & H	12v@B L Gnd	12@B H Gnd	P & E
210	1 & 2, 2 & 3, 2 & 4	12v@2 3 Gnd	12v@2 4 Gnd	1 & 5
280ZX	1 & 4, 1 & 5	12v@1 4 Gnd	12v@1 5 Gnd	2 & 3, 2 & 6, 7 & 8
310 & Pickup	1 & 4 1 & 5	12v@1 4 Gnd	12v@1 5 Gnd	2 & 3
Maxima, Sentra & Stanza	B & L B & H	12v@B L Gnd	12v@B H Gnd	P & E

REAR WIPER MOTOR TESTING

Model	Continuity (Motor Off)	Motor Connections	Park Switch (On-Off with Motor Running)
200SX & Maxima	B & S	12v@B S Gnd	P & E
210	P & E, S & E	12v@1 E Gnd	P & B
280ZX	1 & 4	12v@1 4 Gnd	2 & 3, 2 & 4
310	1 & 4	12v@4 1 Gnd	2 & 3, 2 & 4
Sentra & Stanza	Red/Blue & Blue/Black	12v@Red/Blue Blue/Black Gnd	Blue/White & Black

Fig. 1: Typical Datsun/Nissan Wiper/Washer Components

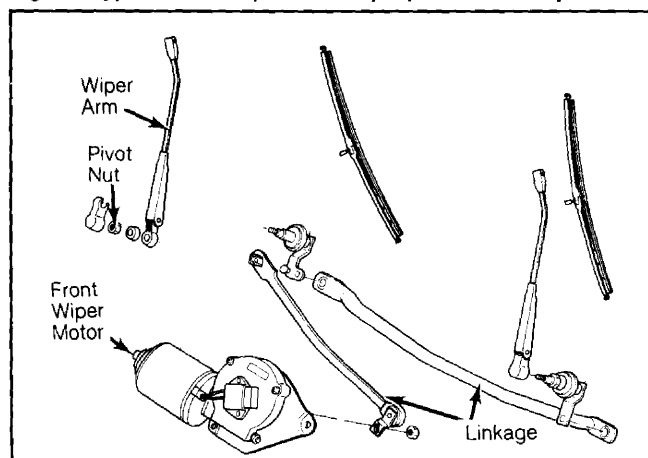

TESTING

FRONT WIPER MOTOR

1) Motor can be tested on the car. Unplug connector and use ohmmeter to check continuity with motor stopped. Using jumper wires, test both motor speeds by applying voltage to terminals shown in "Front Wiper Motor Testing" chart.

2) Finally, check park switch operation by connecting ohmmeter across park terminals while motor is running. Switch should open and close. See Fig. 2.

REAR WIPER MOTOR

1) Motor can be tested on the car. Unplug wiring and use ohmmeter to check continuity with motor stopped. Use jumper wires to operate motor by applying voltage to terminals shown in "Rear Wiper Motor Testing" chart.

Wiper/Washer Systems

DATSUN/NISSAN (Cont.)

Fig. 2: Terminal Identification for Testing Front Wiper Motor

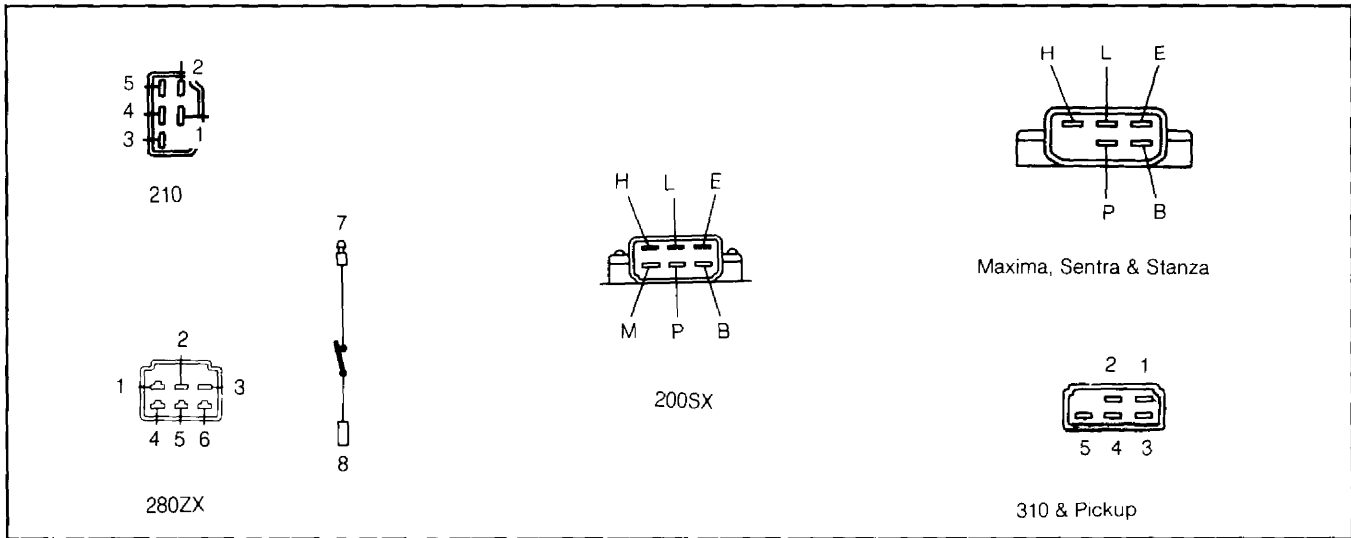
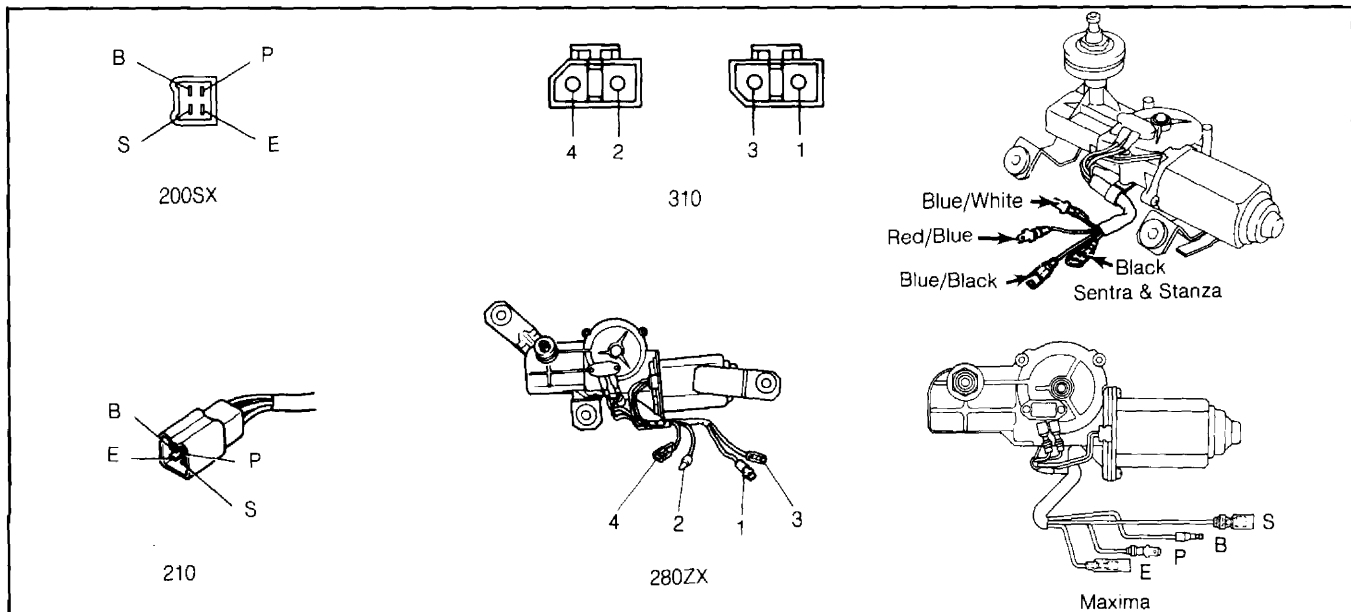

Fig. 3: Terminal Identification for Testing Rear Wiper Motor



2) Check park switch operation by connecting ohmmeter across park terminals while motor is running. Switch should open and close. See Fig. 3.

INTERMITTENT AMPLIFIER

1) Remove amplifier from vehicle or position so jumper wires can be connected to terminals. Use care to prevent improper connections since amplifier can be ruined.

2) Connect test lamp and battery as shown in Figs. 4, 5, 6 & 7. Correct test procedures must be used for the vehicle being tested.

200SX & 280ZX

Connect jumper wires to amplifier. See Fig. 4. When wire "A" is connected, test lamp should come on.

Disconnect wire "B". Test lamp should go off, then come back on after a few seconds. If not, replace amplifier.

210

1) Connect jumper wires as shown for first test. See Fig. 5. Test lamp should come on for 1 second and go off for 6 seconds. Connect wires for second test.

2) Test lamp should come on about 1 second after jumper wire is connected to pin 2. Leave jumper connected for about 5 seconds, then remove it. Test lamp should come on for about 3 seconds.

3) If amplifier fails either test, replace it. Check system operation in all modes.

DATSUN/NISSAN (Cont.)

Fig. 4: Test Connections 200SX & 280ZX Intermittent Amplifier

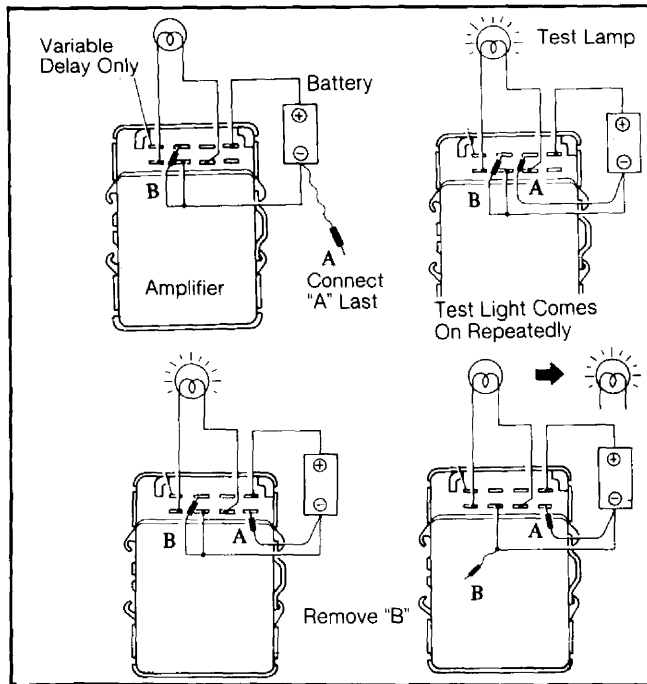

280ZX variable intermittent amplifier is tested in the same manner.

Fig. 5: Test Connections for 210 Intermittent Amplifier

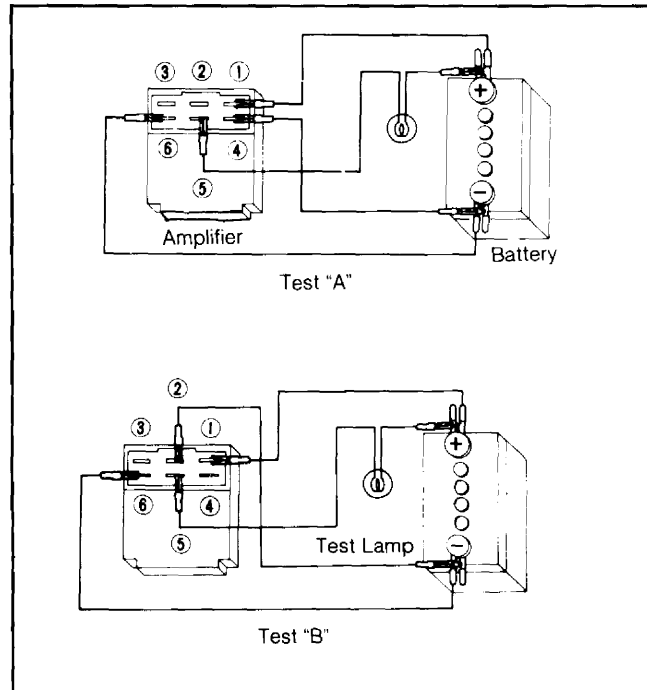

Variable intermittent system not available on 210 models.

310, Sentra & Stanza Variable Intermittent System

Connect jumper wires to amplifier. See Fig. 6. When wire "A" is connected, test lamp should come on. Disconnect wire "B". Test lamp should go off, then come back on after a few seconds. If not, replace amplifier.

Fig. 6: Test Connections for 310, Sentra & Stanza Variable Intermittent Amplifier

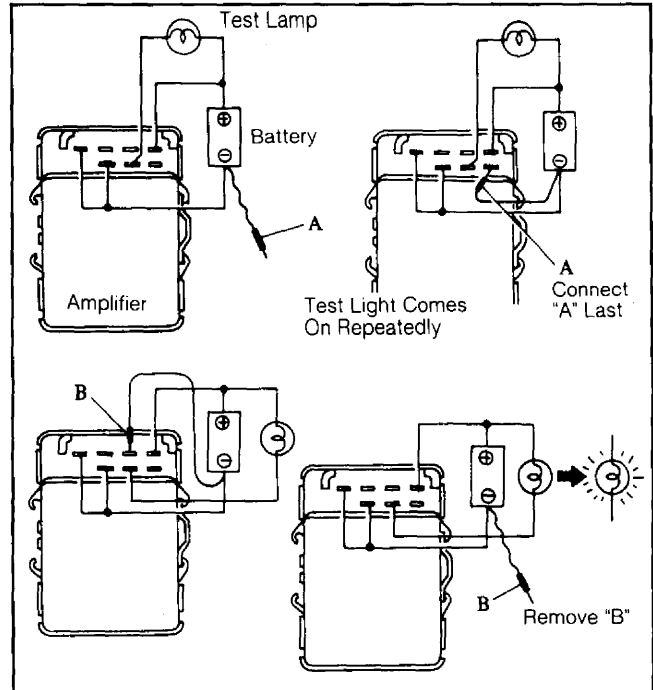

Sentra intermittent system uses a different amplifier.

Sentra Intermittent

Connect test leads to amplifier. See Fig. 7. Test lamp must come on when negative lead wire "A" is

Fig. 7: Test Connections for Sentra Intermittent Amplifier

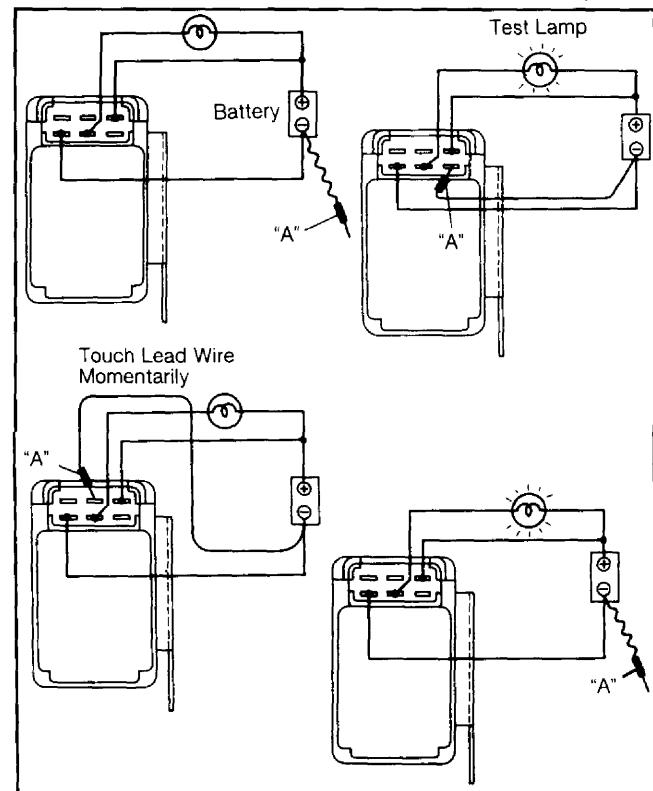

Sentra variable amplifier uses a different amplifier.

Wiper/Washer Systems

DATSUN/NISSAN (Cont.)

connected. Momentarily connect lead wire "A" to top center terminal and then disconnect. Test lamp must come on in a few seconds. Replace amplifier if it fails any test.

Pickup

Connect jumper wires to amplifier. See Fig. 8. Test lamp should come on when wire is connected to pin 3. Disconnect jumper wire from pin 2. Test lamp should go off, then come back on after 6 seconds. If not, replace amplifier.

Fig. 8: Test Connections for Pickup Intermittent Amplifier

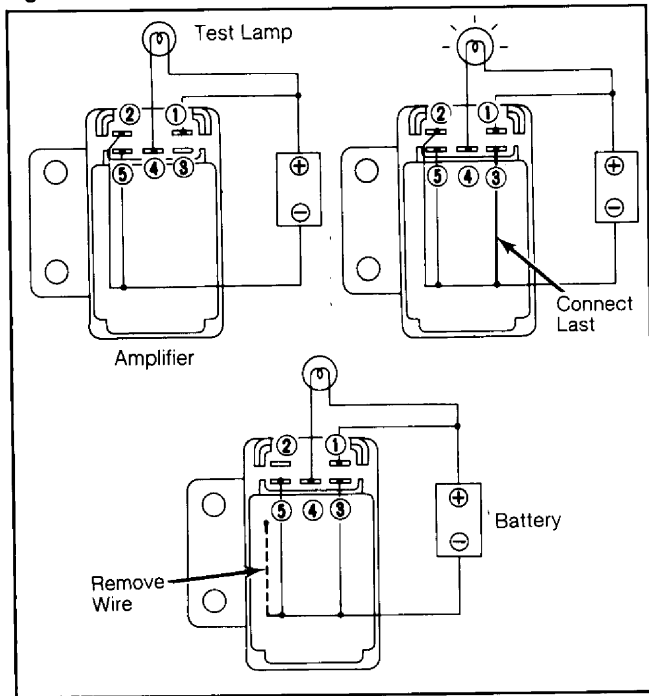

Variable intermittent amplifier is tested in the same manner.

TIME CONTROL UNIT

NOTE: Time Control Unit operates many systems in vehicle. The following tests only check the circuits that control wiper delay operation.

The Time Control Unit is used on Maxima models only. All tests are made using a voltmeter. Insert voltmeter probes into the REAR of connectors while they are still plugged into control unit. Ensure ignition key is in correct position while testing each circuit. Perform tests in order listed.

Power Circuit

Connect negative lead of voltmeter to pin 2 and positive lead to pin 26. Battery voltage should be present with ignition in "ACC" position. If not, check wiring.

Intermittent Circuit

1) Connect negative lead of voltmeter to pin 2 and positive lead to pin 12. Turn ignition "OFF" and set wiper switch to "OFF". Battery voltage should be present. Turn wiper switch to "INT". No voltage should be read. If readings are incorrect, check harness and wiper switch.

2) Connect negative lead of voltmeter to pin 15 and positive lead to pin 1. Turn ignition to "ACC" and wiper switch to "INT". Voltage will vary from 0-12v seconds.

3) Replace time control unit if it does not operate as described. If voltage does not vary, check wiring harness and wiper relay.

4) Connect negative lead of voltmeter to pin 2 and positive lead to pin 16. Turn ignition to "ACC" and wiper switch "ON". Rotate delay adjustment knob at end of wiper lever. Voltage should vary from 0 (short delay) to 8 volts (long delay).

5) If wiper delay cannot be adjusted, but voltage is as described, replace time control unit. If voltage readings are incorrect, check harness and wiper switch.

Fig. 9: Time Control Unit Connector Pin Locations

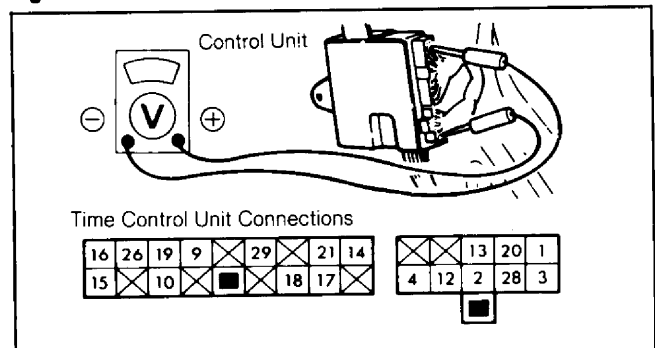

Time control unit is used on Maxima models only.

Washer Circuit

1) Connect negative voltmeter lead to pin 2 and positive lead to pin 14. Turn ignition to "ACC" and pull lever to washer position.

2) Battery voltage should be present with washer off, and no voltage present with washer lever pulled. If not, check washer switch and wiring.

3) Connect negative lead of voltmeter to pin 2 and positive lead to pin 26. Battery voltage should be present with ignition in "ACC" position. If not, check wiring.

4) Connect negative lead of voltmeter to pin 15 and positive lead to pin 1. Rotate lever switch fully counterclockwise, with ignition switch at "ACC" position.

5) Battery voltage should be present briefly every 3 seconds. If not, replace amplifier. If amplifier tests okay, problem is in wiper relay.

WIPER RELAY

The wiper relay is used on Maxima models only. Continuity should be present across terminals 3 and 5. With battery voltage applied to 1 and 2, continuity should be present across terminals 3 and 4. See Fig. 10.

Fig. 10: Wiper Relay Terminal Identification for Testing

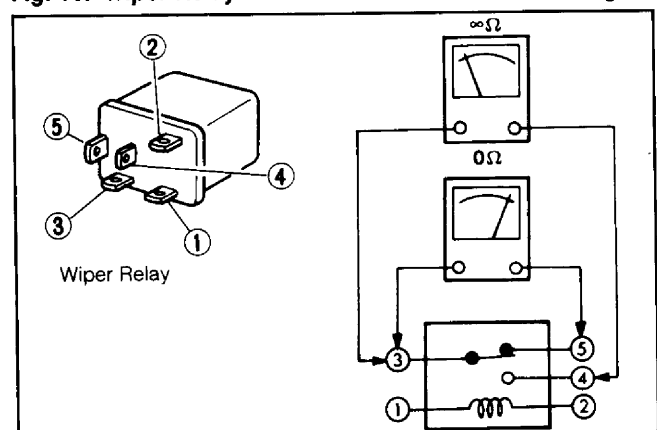

Test connections are for Maxima model only.

DATSUN/NISSAN (Cont.)

REMOVAL & INSTALLATION

FRONT WIPER MOTOR & LINKAGE

Removal (All Models)

1) Disconnect battery ground cable and motor wiring. Remove motor bolts. Remove nut and clip holding linkage arm to motor shaft. Remove motor.

2) Remove wiper arm cap and nut. Remove wiper arm and wiper shaft nut. Remove inspection cover (if equipped) and remove linkage.

Installation

To install, reverse removal procedure. Install arms so parked position is .8" (20 mm) from bottom of windshield.

REAR WIPER MOTOR

Removal (All Models)

Remove wiper shaft nut and wiper arm. Open hatch or tailgate and remove inner panel. Disconnect wiring from motor. Remove wiper motor.

Installation

To install, reverse removal procedure. Install wiper arm so blade is .6-.8" (15-20 mm) from edge of glass when wiper is parked.

COMBINATION SWITCH

Removal (All Models)

Remove steering wheel pad and steering wheel. Disconnect all wiring. Remove retaining screw and pull switch off column.

Installation

To install, reverse removal procedure. Align tab on switch with hole in column.

Fig. 11: 200SX Wiper/Washer System Wiring Diagram

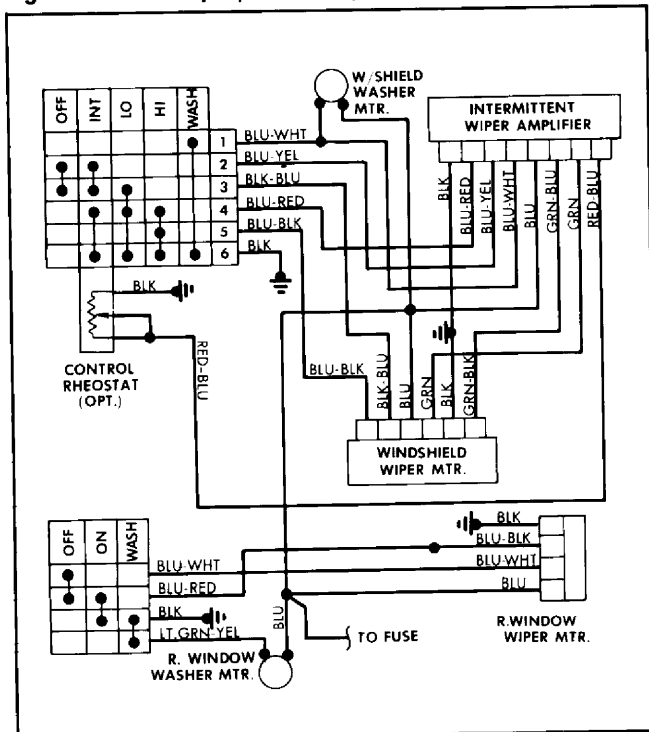

Fig. 12: 210 Wiper/Washer System Wiring Diagram

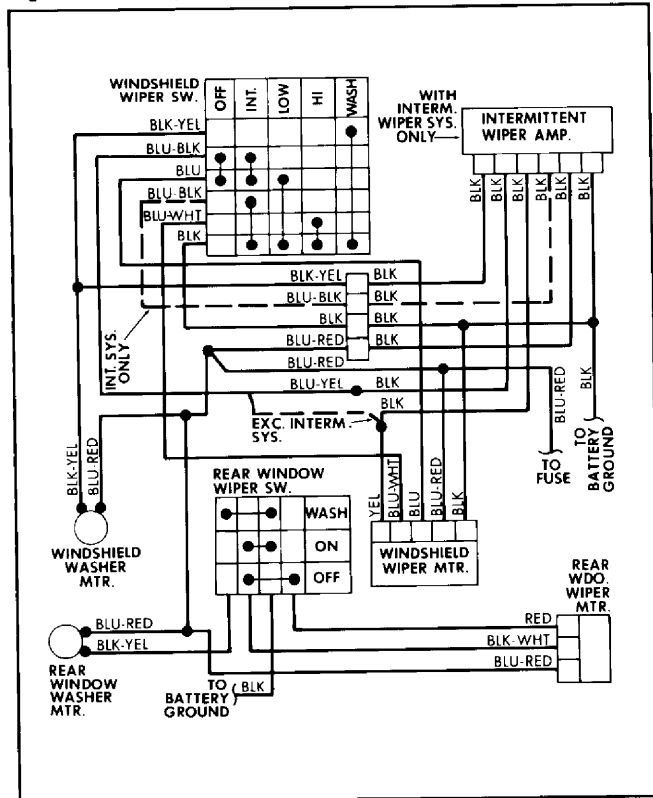
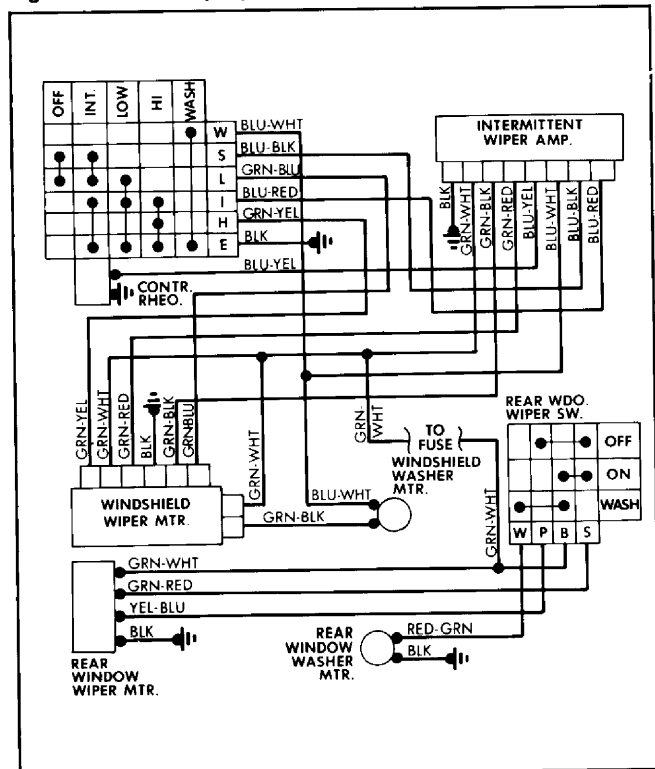

Fig. 13: 280ZX Wiper/Washer System Wiring Diagram



Wiper/Washer Systems

DATSUN/NISSAN (Cont.)

Fig. 14: 310 Wiper/Washer System Wiring Diagram

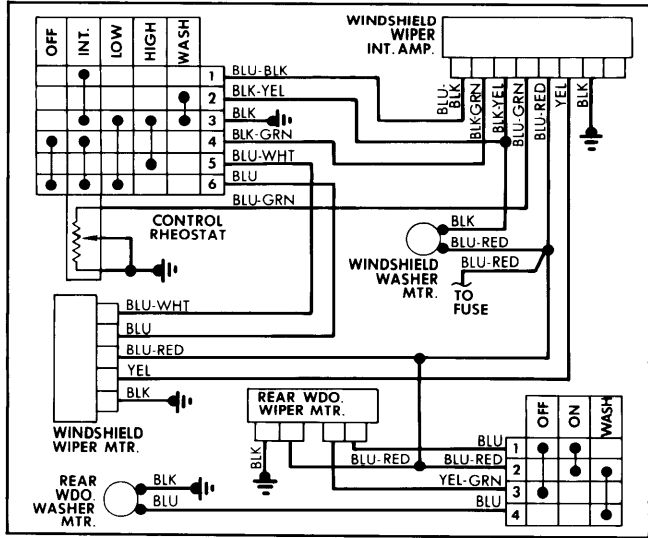

Fig. 15: Maxima Wiper/Washer System Wiring Diagram

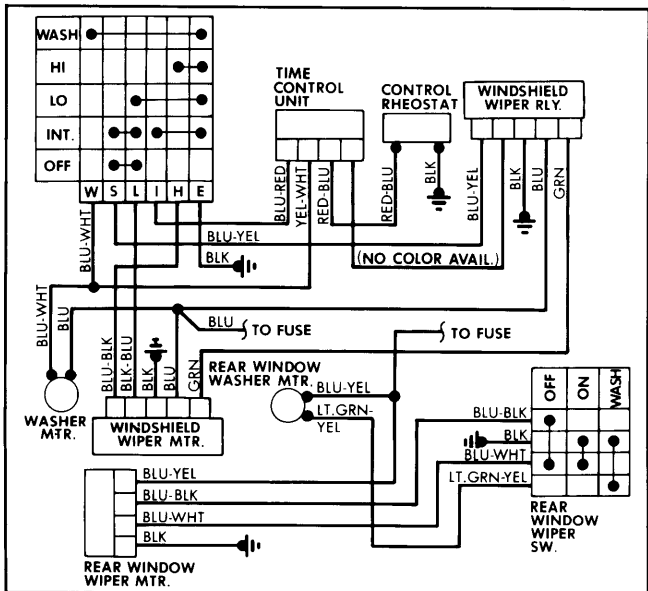

Fig. 16: Pickup Wiper/Washer System Wiring Diagram

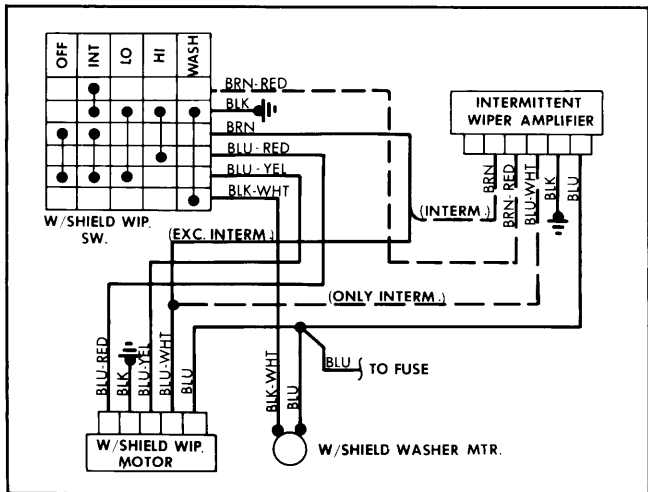

Fig. 17: Sentra Wiper/Washer System Wiring Diagram

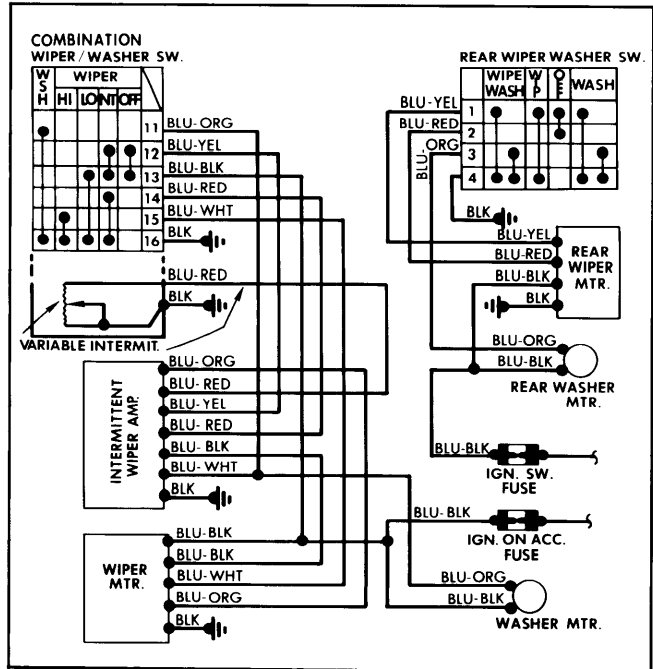

Fig. 18: Stanza Wiper/Washer System Wiring Diagram

