

Switches & Instrument Panels

DATSUN/NISSAN

DESCRIPTION

All models have an instrument cluster that contains the main instrument assembly. This cluster can be removed with all the gauges installed. A combination switch on the steering column includes the wiper switch, lighting switch and turn signals. Other control switches are located on the instrument panel or console.

TROUBLE SHOOTING

GAUGES NOT WORKING

Blown fuse. Faulty voltage regulator. Loose sender connections. Defective sending unit. Loose connections in instrument cluster.

WARNING LIGHTS NOT WORKING

Burned out bulb. Loose connections. Broken printed circuit. Defective sending unit.

HORN NOT WORKING

Blown fuse. Faulty horn switch. Horn relay inoperative. Loose connection or open circuit. Defective horn.

TESTING

Use an ohmmeter to check sensors and switches. Sensors with floats should have continuity when float is in the raised position, and no continuity when float is lowered. Brake lamp and parking brake switches should have continuity when the plunger is in. If sensor does not operate as described, replace it.

REMOVAL & INSTALLATION

COMBINATION SWITCH

Removal & Installation (All Models)

Disconnect battery ground. Remove horn pad and steering wheel. Remove column covers. Unplug connectors, remove mounting screw and slide switch off column. To install, reverse removal procedure.

INSTRUMENT PANEL ASSEMBLY

Removal & Installation (200SX)

1) Disconnect battery ground. Remove steering wheel. Remove steering column covers and combination switch. Remove cover below instruments and disconnect side ventilator air duct.

2) Remove lower left switch assembly below instrument panel. Remove console box. Disconnect wiring connectors from junction box. Disconnect speedometer cable, harness connectors and antenna cable.

3) Remove heater control attaching screws and floor attaching bolts. Remove defroster grille. Remove instrument securing bolts and pull instrument panel out. To install, reverse removal procedure.

Removal & Installation (210)

1) Disconnect battery ground. Remove steering wheel pad and wheel. Remove steering column cover. Remove panel light dimmer. Pull out heater knob and remove heater bezel. Remove heater screws.

2) Pull off radio knobs and remove shaft nuts. Pull out ashtray and remove holder screws. Remove 3

Fig. 1: Exploded View of 200SX Instrument Panel

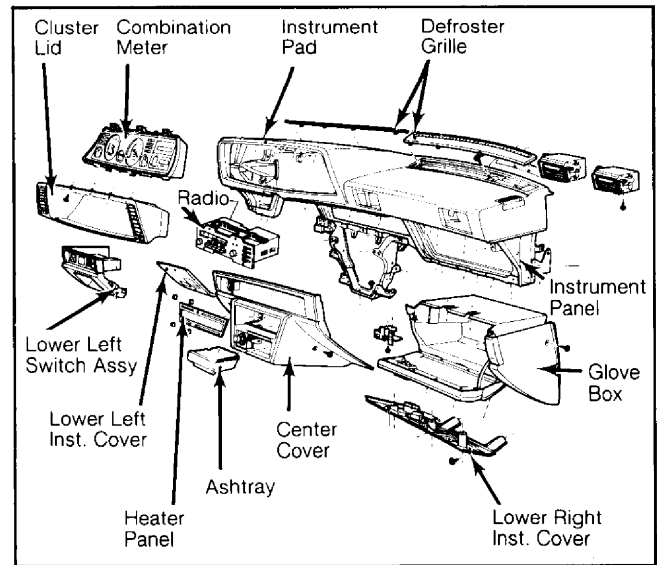

screws above instruments, 1 screw on each side of column (under dash) and 1 screw at left edge of panel. Unplug all wiring and speedometer cable.

3) Remove left half of instrument panel. Remove retaining screws and lift off combination meter assembly. Gauges can be removed after front bezel and mask are taken off. To install, reverse removal procedure.

Removal & Installation (280ZX)

1) Disconnect battery ground. Remove horn pad, steering wheel and column covers. Remove instrument left lower cover. Disconnect speedometer cable at intermediate connection.

2) Remove combination switch. Remove combination retaining screws. Carefully pull out instrument panel. Disconnect connector whose leads are connected to instrument panel and remove instrument panel.

3) To remove gauge unit from center of dash, remove glove box. Disconnect instrument harness connector and remove screw retaining combination gauge. Pull out on combination gauge while pushing out toward front of vehicle. To install, reverse removal procedure.

Fig. 2: Exploded View of 280ZX Instrument Panel

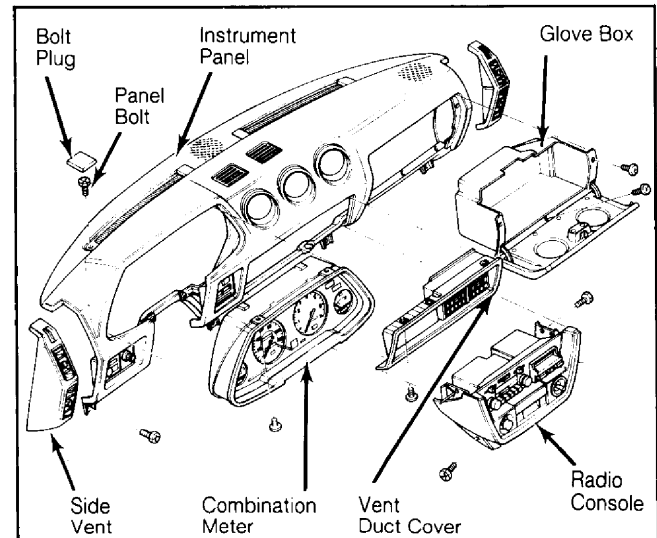

DATSUN/NISSAN (Cont.)

Removal & Installation (310)

1) Disconnect battery ground. Remove horn pad, steering wheel and column cover. Remove lower left cover. Disconnect speedometer cable. Unplug wiring harness connectors.

2) Remove choke knob and nut. Remove heater control knobs and heater control panel screws. Remove 2 bolts at each end of instrument panel. Remove 2 bolts below center of instrument panel.

3) Insert a thin wire between cluster lid and edge below windshield. Pull off cluster mask with wire. See Fig. 3. Remove bolts attaching center of panel to firewall. Remove steering column bracket bolts. Pull panel up and back to remove from vehicle. To install, reverse removal procedure.

Fig. 3: Inserting Wire to Remove Instrument Panel Mask on 310

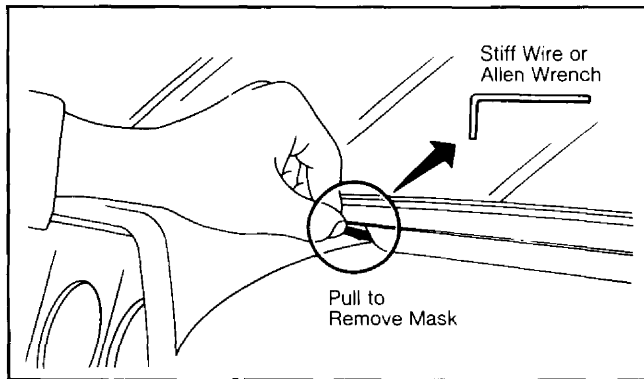

Removal & Installation (Maxima)

1) Disconnect battery ground. Remove left lower cover. Remove fuse block and unplug wiring from junction block. Remove steering wheel. Remove column covers and combination switch.

2) Loosen tilt lever and lower column. Disconnect speedometer cable and antenna cable. Remove choke knob. Remove 5 screws under top edge of cluster pad and 2 screws at bottom ends. Remove pad and cluster bezel.

Fig. 4: Exploded View of Maxima Instrument Panel Assembly

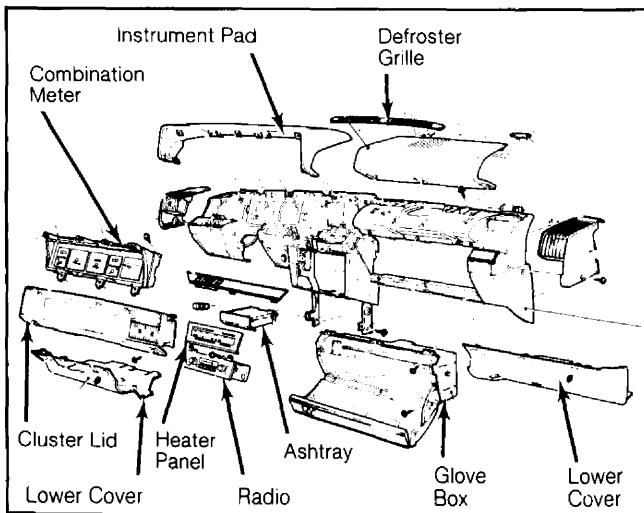

3) Open console box and remove mat. Remove screw inside box. Remove console. Remove heater control bezel. Remove heater panel screws and radio. Remove defroster grille and heater nozzle on left side.

4) Remove mounting screws for instrument panel and removal panel. To install, reverse removal procedure.

Removal & Installation (Pickup)

1) Disconnect battery ground. Remove steering column cover. Remove package tray (if equipped). Disconnect speedometer cable.

NOTE: Cluster lid and combination meter can be removed at this point if necessary.

2) Unplug wiring for center light, rear defogger, lighter, clock and turn signal switch. Remove 3 instrument panel top bolts (under plugs). Remove bolt above parking brake and bolt in glove box.

3) Remove 2 bolts at each end of instrument panel. Remove panel from vehicle. To install, reverse removal procedure.

Removal & Installation (Stanza)

1) Loosen tilt adjusting lever, and lower steering column completely. Remove steering column cover. Remove retaining screws and tilt cluster lid forward. Then slightly lift the cluster lid while releasing front nails.

2) Remove retaining screws and pull instrument panel out. Disconnect speedometer cable and harness connectors, and remove instrument panel. To install, reverse removal procedure.

Fig. 5: Exploded View Stanza Instrument Panel

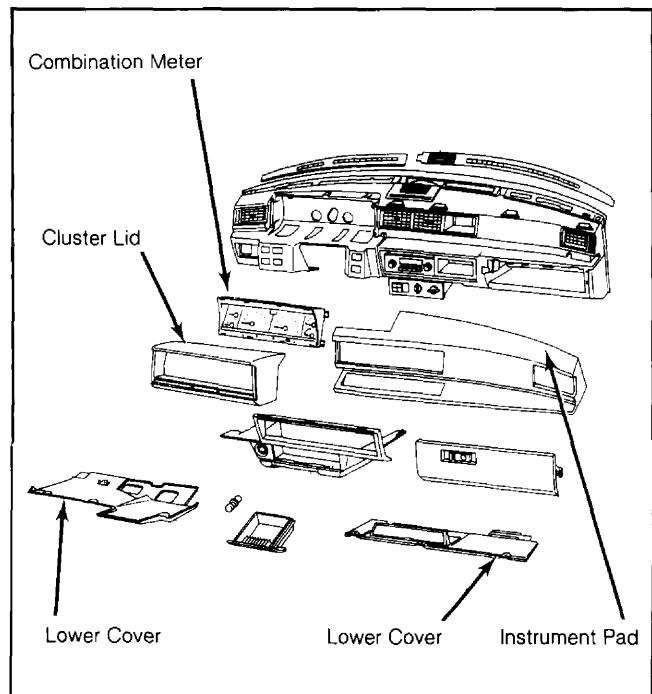

Removal & Installation (Sentra)

Remove steering wheel and steering column cover. Remove attaching screws and cluster lid. Remove 4 attaching screws and pull out instrument panel out far

Switches & Instrument Panels

DATSUN/NISSAN (Cont.)

enough to disconnect speedometer cable. Remove instrument panel. To install, reverse removal procedure.

Fig. 6: Exploded View of Sentra Instrument Panel

