

NIPPONDENSO DIRECT DRIVE

Courier; Honda Civic (Calif. Only); Subaru (1600 cc Only); Toyota Land Cruiser, Starlet, Tercel

NOTE: Some Calif. Honda Civics are equipped with Hitachi starters. See appropriate article in this section.

DESCRIPTION

The Nippondenso direct drive starter is a conventional 12-volt, 4-pole, brush-type starter. The integral solenoid is attached to the drive housing. When the starter is energized, the solenoid causes the starter pinion to engage the flywheel ring gear.

The overrunning clutch pinion drive is mounted directly on the drive end of the armature shaft. Although starters may have varying kilowatt ratings, testing and service procedures are similar.

APPLICATION

Model	Part No.
Courier	
2000 cc	E17Z 11002A
2300 cc	
Man. Trans.	E17Z 11002C
Auto. Trans.	E17Z 11002B
Honda Civic	
Calif.	31200 PC1 004
Subaru 1600 cc	² 42991 7000
Toyota Land Cruiser	28100 60042
Starlet	28100 13020
Tercel	28100 15011

¹ — Vehicle manufacturer's part number.

² — Nippondenso model number is 028000-2970.

TESTING

PERFORMANCE TESTS

No Load Test

Place starter on bench. Using a fully-charged 12-volt battery, make connections as shown in Fig. 1. Starter should rotate smoothly at more than 5000 RPM, drawing less than 50 amps. at 11 volts.

NOTE: On Starlet models with .8 kw type starter, draw should be less than 55 amps at 11 volts.

Lock Test

To perform lock test, follow procedures outlined in tester instruction manual. With starter locked in test stand and voltage adjusted to 7.7 volts, torque should register 9 ft. lbs. (12 N.m) at less than 600 amps.

Cranking Test (Calif. Honda Civic)

1) Hook up voltmeter and ammeter as shown in Fig. 2. Disconnect ignition coil secondary wire from distributor and ground it. Turn ignition switch to start.

2) Check cranking voltage and current draw. Voltage should be no less than 8.0 volts for Civic.

Fig. 1: Circuit for No Load Test

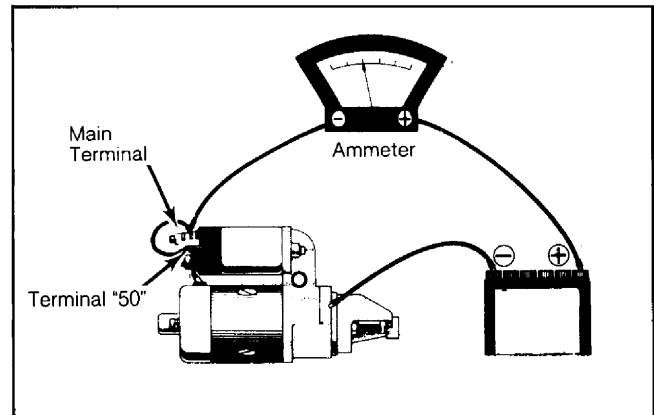

Connect battery and ammeter as shown.

3) Current draw should be no more than 200 amps for Calif. Civics. Cranking speed should be approximately 300 RPM.

Fig. 2: Cranking Test Hookup for Honda Civic

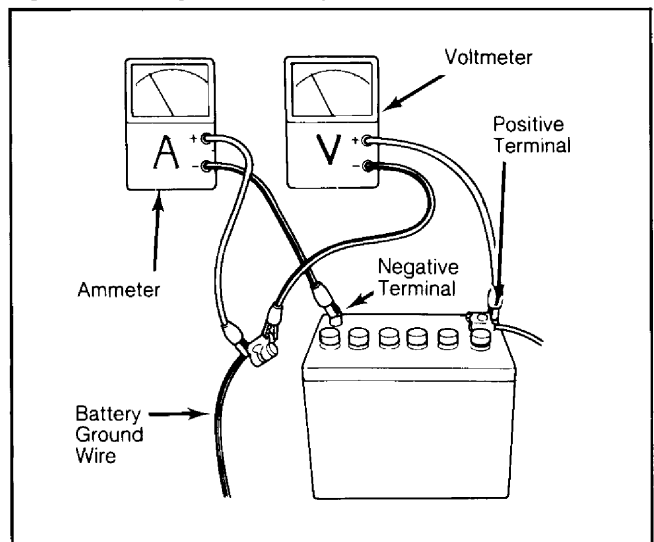

Be sure voltmeter and ammeter connections are correct.

SOLENOID TESTS

NOTE: Tests must be performed with starter assembled and "M" (field) lead from starter disconnected at the solenoid. Plunger and sleeve must be clean and dry.

Pull-In Test

Connect test equipment as shown in Fig. 3. Battery negative is connected to starter body and "C" terminal ("M" on Subaru). Battery positive is connected to terminal "50" ("S" terminal on Subaru). If plunger has definitely jumped out, pull-in coil is satisfactory.

Hold-In Test

Connect leads as shown in Fig. 3. Disconnect "C" terminal ("M" terminal on Subaru). The pinion should remain projected. If the pinion does not remain projected, hold-in coil is defective and must be replaced.

Starters

NIPPONDENSO DIRECT DRIVE (Cont.)

Fig. 3: Solenoid Test Hookup

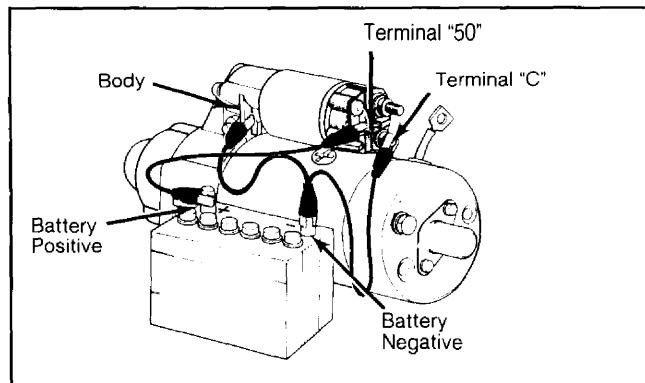

"M" (field) lead should be disconnected at solenoid.

Plunger Return Test

Connect leads as shown in Fig. 3. Disconnect switch body lead. When disconnecting switch body, the pinion should return quickly.

OVERHAUL

DISASSEMBLY

1) Disconnect field coil wire from starter solenoid main terminal and remove solenoid attaching bolts. Remove solenoid by moving it up and down to unhook unit from drive lever.

2) Remove bearing cover, and pull out armature shaft lock plate, washer, seal and spring. Remove through bolts, commutator end frame, brush holder, and yoke.

3) Remove drive lever set bolt, rubber piece, plate, armature, and drive lever from housing. Remove pinion stop collar from armature shaft end, and remove starter clutch.

PARTS REPLACEMENT & TESTING

Armature

Check armature for open, shorted or grounded circuits. Check armature shaft for bend. Inspect bushings for condition and maximum clearance of .008" (.20 mm). Replace if required.

NOTE: Do NOT attempt to straighten a bent armature shaft. Replace if bent.

Commutator

1) Clean contact surface and polish with No. 400 sandpaper if required. If surface is scored, burned, out of round or pitted, dress in a lathe only enough to restore smooth concentric surface.

2) Out of round should not exceed .016" (.4 mm) on Subaru and .012" (.3 mm) on all other models. Mica depth should be .016-.031" (.40-.80 mm) standard with a limit of .008" (.20 mm). If beyond limit, undercut with a hacksaw blade to standard depth.

Brushes & Springs

1) Check brush holder insulation. Connect one lead of ammeter to brush holder positive side and other lead to negative side. If test needle moves, brush holder is shorted and must be replaced.

2) Check brush length. On Subaru models, if less than .43" (12 mm), replace brushes. On all other models, if less than .39" (10 mm) replace brushes. Check

spring tension. Minimum tension for Courier is 38 ounces (1077 g).

3) Minimum tension for Toyota Land Cruiser and Tercel models is 35 ounces (1020 g). On Starlet models, spring tension should be 37-46 ounces (1049-1304 g) on .6 kw type starter; 35-48 ounces (993-1361 g) on .8 kw type.

4) Spring tension for Subaru should be 37-48 ounces (1050-1350 g). Brushes must move freely in holders.

Field Coils

1) Connect a prod of circuit tester lead to field coil. Connect other prod to soldered portion of brush lead. If meter does not register, field coil is open and must be repaired or replaced.

2) Check field coil for ground by connecting a test prod to field coil lead. Connect other prod to starter housing. If meter registers, coil is grounded and must be repaired or replaced.

REASSEMBLY

1) Clean all parts and coat sliding surface of armature shaft splines, starter clutch bushing, drive lever and moving stud with multipurpose grease.

2) Reassemble in reverse order of disassembly and note the following. After completing reassembly, if clearance between pinion gear and stop collar is not .080-.160" (.20-4.0 mm) for Courier or .004-.160" (.10-4.0 mm) for all other models, adjust by lengthening or shortening plunger shaft.

Fig. 4: Exploded View of Typical Nippondenso Direct Drive Starter Motor

