

DUCELLIER & PARIS-RHONE

Peugeot 504, 505, 604; Renault Fuego, Fuego Turbo, Le Car, 18i

DESCRIPTION

Starter is a conventional, 12-volt, 4-pole unit with a solenoid assembly mounted on the starter case. Starter has an overrunning clutch, connected by a shift lever to the solenoid plunger.

APPLICATION

Model	¹ Part No.
Peugeot	
504	5802.33
505 Diesel	5802.33
505 Gas	
Ducellier	5802.20
Paris-Rhone	² 5802.20, ³ 5802.34
604	5802.04
	5802.33
Renault	
Fuego & Fuego Turbo	D10 E79
Le Car	D10 E79
18i	D10 E79
	D10 E63

¹ — Vehicle manufacturer's for Peugeot applications; Paris-Rhone's for Renault.

² — Paris-Rhone No. D9 E27.

³ — Paris-Rhone No. D9 E54.

TESTING

LOCK TEST

Le Car

Follow instructions and procedures outlined in manual furnished with tester. Use a fully-charged battery, and carry out the test at a temperature of 77°F. Starter torque should be 9 ft. lbs. (12 N.m) at 400 amps.

Fig. 1: Disassembled View of Paris-Rhone D10 E79 Starter

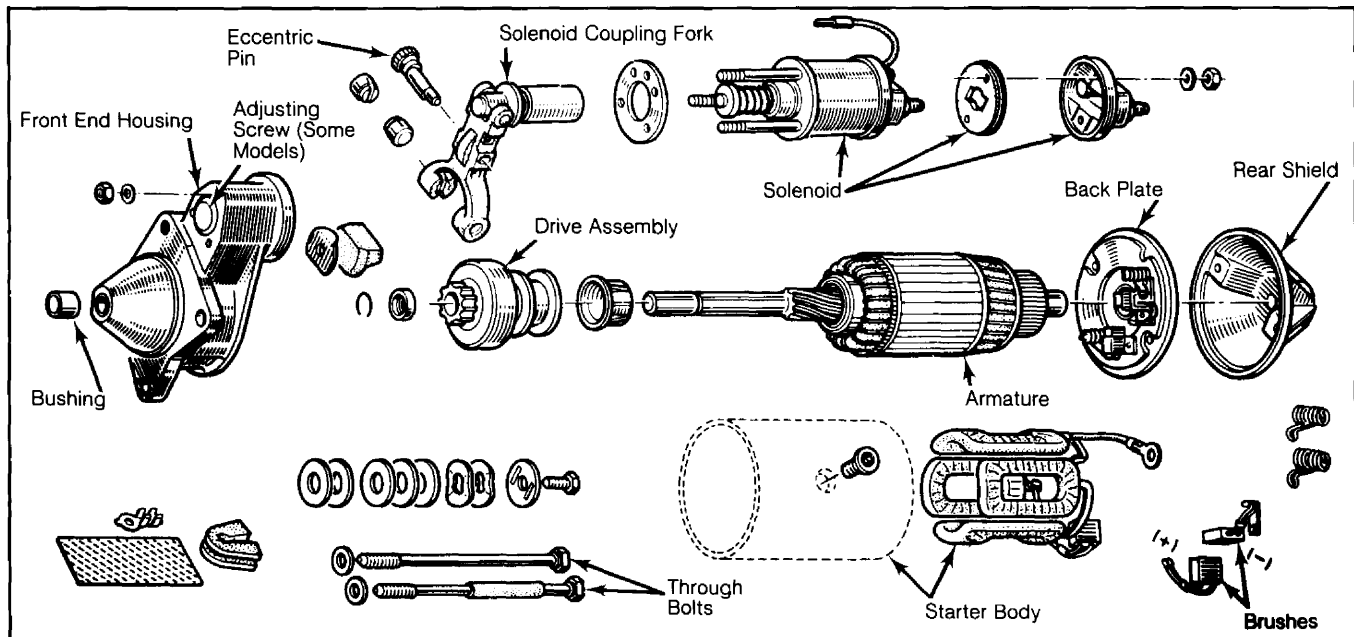

Paris-Rhone D10 E63 Starter has 4-bolt solenoid assembly.

Fuego & Fuego Turbo

Follow instructions and procedures outlined in manual furnished with tester. Use a fully-charged battery, and carry out the test at a temperature of 77°F. Starter torque should be 14 ft. lbs. (19 N.m) at 600 amps.

OPERATIONAL TEST

Peugeot

1) Disconnect coil high tension wire (except diesel). Connect tachometer to engine. Connect ammeter between battery and starter. Energize starter for maximum of 15 seconds.

2) Gasoline engine should turn at 120 RPM with a maximum draw of 250 amps. Diesel engine should turn at 120 RPM with a maximum draw of 350 amps.

NOTE: Further test procedures are not furnished by manufacturer.

OVERHAUL

DISASSEMBLY

1) Disconnect wire between starter motor and solenoid. Remove nuts on through bolts, and remove rear shield and back plate. Carefully lift out brushes. Remove clip on end of armature, if equipped.

2) Remove rear bearing on armature shaft. Remove armature housing. Remove connecting fork retaining pin (between starter and solenoid). Remove nuts securing solenoid. Remove solenoid and armature.

PARTS REPLACEMENT & TESTING

Brushes

Inspect brushes. If damaged or less than 5/16" (8 mm) long, install new brushes. Unsolder brushes to be replaced. Solder on new brushes. Check armature and reassemble.

Starters

DUCELLIER & PARIS-RHONE (Cont.)

Commutator

Check commutator surface for burns, pits, gouges, scoring or out-of-round. Dress with a lathe if required, and polish with fine sandpaper. Check segment insulators undercut to depth of .020" (.5 mm).

Drive Pinion

To remove drive pinion from armature, tap stop collar with a drift. This will remove circlip holding drive pinion. To install, position circlip on shaft and push stop collar over it.

Armature

Check armature for open, shorted or grounded circuits. Inspect armature shaft for bend, and core for scoring or loose windings.

NOTE: Do not attempt to straighten a bent shaft. Replace armature if shaft is bent or if core is damaged.

Bearings

Inspect front and rear bearings for wear and excessive clearance with armature shaft. Replace if damaged or in case of excessive clearance.

REASSEMBLY

1) Clean all parts and coat sliding surfaces with multi-purpose grease. Assemble in reverse order of disassembly and check pinion clearance.

2) Disconnect starter field terminal from solenoid and energize solenoid with 12 volt battery. Measure clearance of pinion gear to stop collar.

3) Clearance should be .06" (1.5 mm). Adjust to proper clearance by turning eccentric pin in solenoid fork or turning adjusting screw in front of solenoid in or out.