

## NIPPONDENSO REGULATORS

Honda Accord, Civic, Prelude; Toyota Celica, Corolla, Corona, Cressida, Land Cruiser, Pickup, Starlet, Supra, Tercel

### DESCRIPTION

Remote Nippondenso regulators may be either single or double element type. Single element type has a voltage regulator element only, while 2-element type has both voltage regulator and a voltage warning relay.

Single element type is normally fitted to units with an ammeter, while double element type normally has a charge warning light.

### APPLICATION

Model	<sup>1</sup> Part No.
Honda	
All Models .....	31400-SA5-004
Toyota	
Celica, Corolla, Corona, Cressida .....	27700-43010
Land Cruiser	
Standard Type .....	27700-13060
IC Type .....	27700-38100
Pickup	
Diesel .....	27700-57060
Gas	
Standard .....	27700-35010
IC Type .....	27700-38100
Starlet .....	27700-13090
Supra .....	27700-43010
Tercel .....	27700-13060

<sup>1</sup> — Vehicle manufacturer's part number. Some regulators are integrated circuit (IC) type. Part number furnished for information only.

### TESTING

#### VOLTAGE REGULATOR

**NOTE:** Substitution of a known good regulator for one suspected of malfunctioning will frequently save time during testing.

#### Toyota No Load Test

1) Disconnect wire from "B" terminal of alternator, and connect to ammeter negative lead. Connect ammeter positive lead to "B" terminal of alternator.

**NOTE:** If a battery/alternator tester is available, connect and test according to tester manufacturer's instructions.

2) With engine running at varying speeds from idle to 2000 RPM, voltage should be 13.8-14.8 volts. Amperage should be less than 10 amps. If not within specifications, adjust or replace regulator as required. See Adjustment.

#### Toyota Regulator Circuit Resistance Test

1) Disconnect regulator connector. Using an ohmmeter, check resistance between regulator terminals "IG" and "F". See Fig. 1. Resistance should be zero (0) when at rest, and approximately 11 ohms when pulled in.

Fig. 1: Identification of Toyota Regulator Connector Terminals

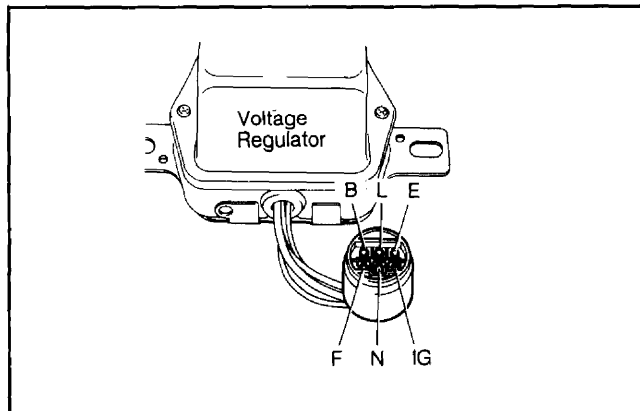

Check regulator resistance as indicated.

2) Measure resistance between terminals "L" and "E". Reading should be zero (0) ohms at rest, approximately 100 ohms when pulled in.

3) Measure resistance between terminals "B" and "E". Reading should be infinity at rest, and approximately 100 ohms when pulled in.

4) Measure resistance between terminals "B" and "L". Reading should be infinity at rest, and zero (0) ohms when pulled in.

5) Measure resistance between terminals "N" and "E". Reading should be approximately 23 ohms.

6) If any of the above checks are not to specifications, replace regulator.

#### Honda Voltage Regulator No Load Test

1) Turn all lights and accessories off. Check all fuses. With engine idling, remove negative cable from battery. Connect voltmeter negative lead to disconnected negative cable. See Fig. 2. Connect voltmeter positive lead to battery positive cable.

Fig. 2: Voltmeter/Ammeter Hookup for Honda No Load Test

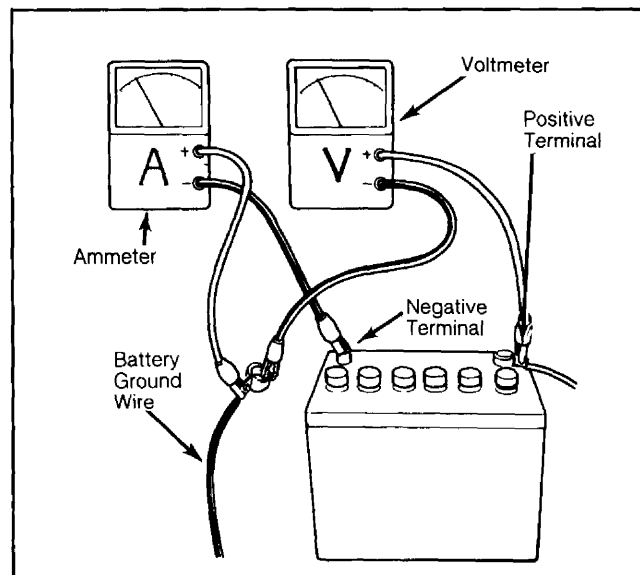

Observe polarity to prevent shorts.

# Alternators & Regulators

## NIPPONDENSO REGULATORS (Cont.)

2) If engine continues to run, proceed to step 5). If engine immediately stops when negative cable is disconnected, reconnect cable and start car. Check voltage at Black/Yellow wire at regulator connector.

3) If there is no voltage, check for continuity between 10 amp. regulator/fuel pump fuse and connector J27. Repair or replace parts as necessary. If voltage was present, check White/Red wire for system voltage at all connectors between regulator and alternator.

4) If voltage is available at alternator, check alternator output. If no voltage in White/Red wire at regulator, replace regulator.

5) Vary engine speed from 2000-4000 RPM, and note voltage reading. Reading should be 13.5-14.5 volts. If not within specifications, adjust voltage relay.

adjustment, recheck cut-in or regulated voltage. If not within specifications, repeat voltage adjustment.

**NOTE:** Regulator cover must be installed after adjustments prior to further testing.

### ADJUSTMENT

**NOTE:** Adjustments are not applicable to sealed units. If points are slightly oxidized or pitted, dress contacts with sandpaper (400 grit or finer). If points are oxidized or pitted excessively, replace regulator assembly.

#### Voltage Regulator & Relay

1) For relay, connect voltmeter between "N" terminal (White wire) and ground. Gradually increase engine speed. Voltmeter reading should be 4.0-5.8 volts when indicator light goes out. See Fig. 3. For regulator, connect voltmeter as described under testing. Adjust regulator and relay by bending adjusting arm as follows.

**Fig. 3: Adjustments for Voltage Relay**

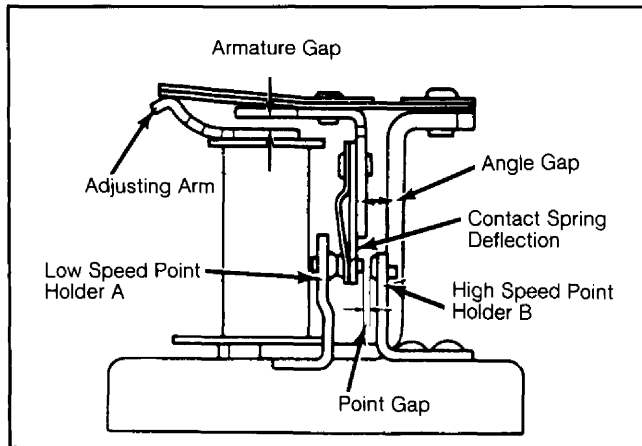

*Voltage regulator adjustment is similar.*

2) If cut-in or regulated voltage is too high, adjust by bending core adjusting arm down. Bend arm up if voltage is too low. If adjustment of core arm does not correct voltage, proceed with point gap adjustment. Disconnect negative cable from battery.

3) Check armature core gap with armature depressed until moving point is in contact with "B" side point. Armature core gap should be .02" (.5 mm) or more. Adjust by bending point arm "B". Release the armature and adjust the gap between the "B" side point and the moving point by bending point arm "A".

4) Point gap should be .016-.047" (0.4-1.2 mm). Angle gap should be .02" (.5 mm) or more. After