

Alternators & Regulators

BOSCH REGULATORS

Audi, BMW, Fiat, Mercedes-Benz,
Porsche, Saab, Volkswagen, Volvo

DESCRIPTION

Bosch regulators are provided in either transistorized solid state or the vibrating contact type. Vibrating type is mounted separate from alternator. Solid state type may be integral with alternator or separately mounted.

Vibrator model is designated "ADN", and externally mounted solid state type is designated "ED". Integral mounted solid state regulator is designated "EE".

NOTE: For Regulator Applications and additional Testing procedures, see Bosch Alternators in this Section.

Fig. 1: Bosch Vibrator Type Alternator Regulator

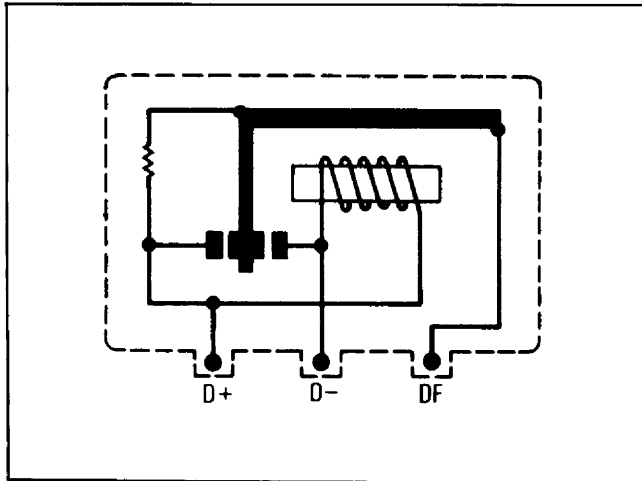
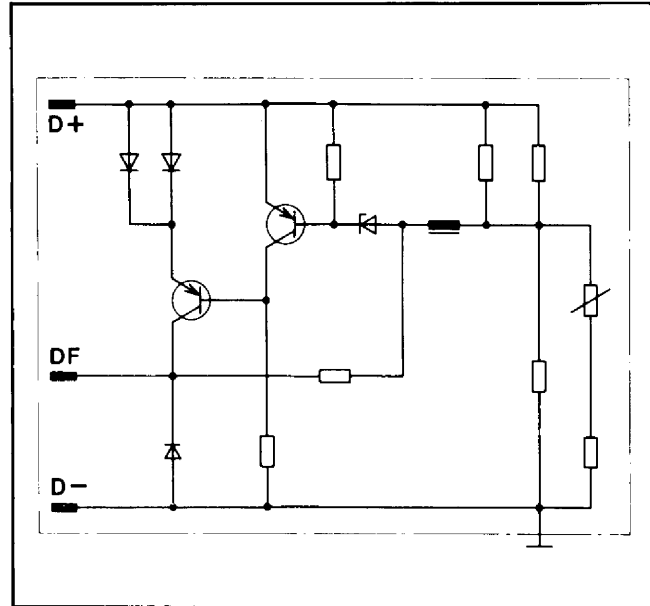

Fig. 2: Typical Bosch Transistorized Voltage Regulator Wiring Diagram



TESTING

ON-VEHICLE TEST

Vibrator Type

1) Install a battery post adapter at the positive post of the battery. Connect voltmeter across battery. Connect a tachometer to ignition system. Make sure all electrical accessories are turned off.

2) Start engine with battery post adapter switch closed; open switch as soon as engine is started. With engine speed at 4000 RPM, after voltage reading stabilizes, any reading between 13.7 and 14.8 volts is satisfactory.

Transistorized (Solid State) Regulators

1) All applicable regulators are designed to maintain from 13.7 to 14.5 volts at a load current of 5 to 7 amps. Alternator should be driven at 4000 RPM and load current set at load current rating.

2) Resistance and speed of alternator may be readjusted if necessary. Read voltage within 1 minute. If not within specifications, regulator requires replacement.

ADJUSTMENT

If regulator fails to keep voltage within specified limits, it must be replaced. No adjusting procedures are recommended.