

SAAB

900
900 Turbo

DESCRIPTION & OPERATION

All models have a 2-speed wiper motor that operates the wiper arms through a cable and linkage. The wiper control switch is a steering column lever. The intermittent control relay is located next to the turn signal flasher (on relay bracket under left side of dashboard). The wiper switch operates the washers when it is pulled toward the steering wheel. As the lever is moved down, the wipers operate intermittently, at low speed and at high speed.

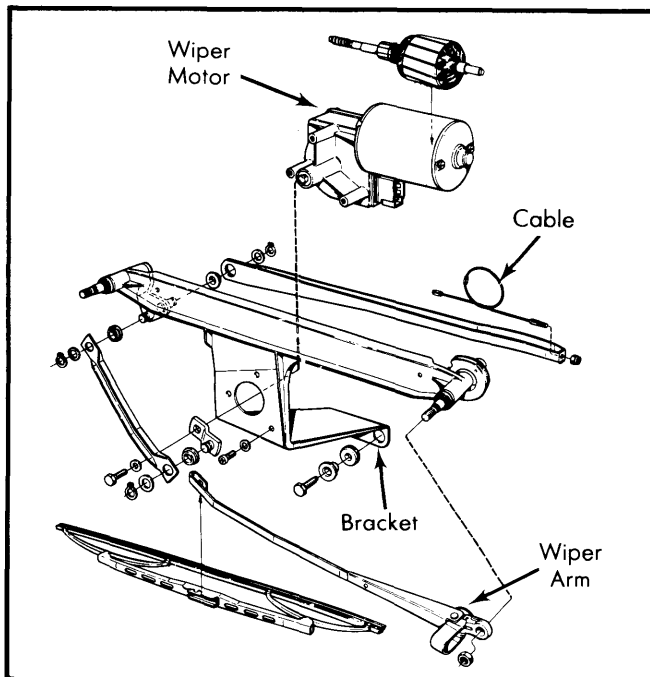

Fig. 1 Saab 900 Wiper Motor Assembly. Remove Wiper Arms and 4 Bolts to Remove

REMOVAL & INSTALLATION

WIPER MOTOR

Removal — Lift wiper arm. Fold cap up and remove wiper shaft nut. Remove wiper arms and rubber shaft covers. Remove bolts at wiper bracket and one bolt at each shaft. Unplug wiring and remove motor assembly with bracket.

Installation — To install, reverse removal procedure.

WIPER SWITCH

Removal — Remove lower steering column cover. Remove screws under steering column and slide switch bracket off steering shaft. Unplug wiring and remove switch.

Installation — To install, reverse removal procedure.

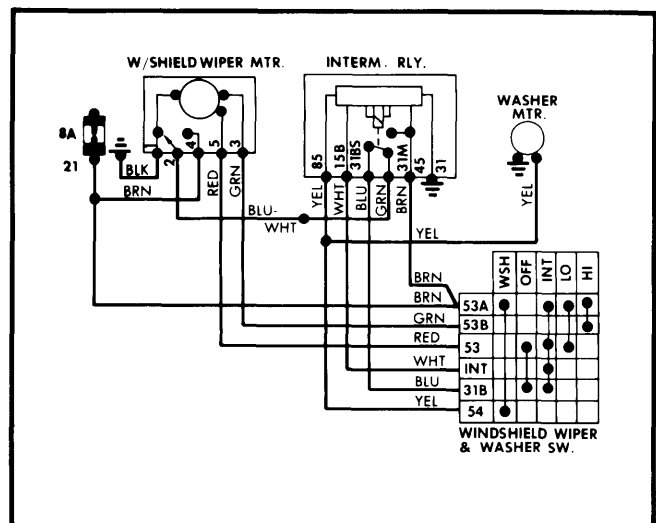

Fig. 2 Saab 900 Wiper/Washer System Wiring Diagram