

RENAULT

Le Car
18i

DESCRIPTION

All models are equipped with 2-speed wiper motors. The 18i model also has an intermittent cycle. A rear wiper/washer is available on Le Car and 18i Station Wagon models. The Le Car rear washer has a reservoir in the rear of the car, while the 18i uses the front fluid reservoir. The 18i rear pump is inside the pillar behind the left rear door.

OPERATION

The wipers are controlled by the right column lever. Pulling the lever toward the steering wheel operates the washers. Moving the lever downward operates the intermittent cycle (18i only), low speed and high speed. The rear wiper is controlled by a push button switch. Hold the switch to operate the washer and wiper.

TESTING

WASHER MOTOR

If motor does not operate, connect a jumper wire from battery to the motor pink wire. If motor still does not work, check pump motor ground connection. If it does not operate, replace motor. If motor now operates, but not with switch, check wiring or replace switch.

REMOVAL & INSTALLATION

FRONT WIPER MOTOR

Removal (Le Car) - 1) Raise base of wiper arm and remove nut. Pull off wiper arms and remove shaft nuts. Remove electrical box, 2 motor plate bolts and pull motor assembly out to the side.

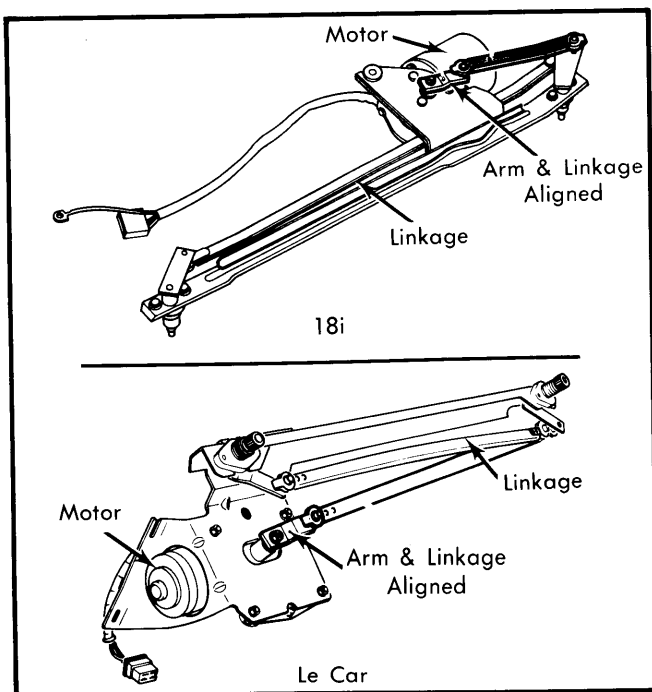

Fig. 1 Wiper Motor Crank Arm Position.
Motor Must Be In Park Position When Nut is Tightened.

2) Remove motor crank arm nut. Remove motor mounting bolts and pull motor from bracket.

Installation - Place motor on bracket and tighten bolts. Crank arm must be in line with linkage when motor is in park position. See Fig. 1. Reverse removal procedure to complete installation.

Removal (18i) - 1) Remove wiper arms and shaft nuts. Remove electrical box, ground wire and motor plate bolt. Push shafts into body and slide motor assembly to the right.

2) Remove crank arm nut and motor bolts. Remove motor from linkage assembly.

Installation - Install motor on linkage assembly. Motor crank arm must be in line with linkage arm when motor is in park position. Reverse removal procedure to complete installation. See Fig. 1.

REAR WIPER MOTORS

Removal (All Models) - Remove inner trim panel. Disconnect motor wiring. Remove wiper blade, arm and shaft nuts. Remove motor bolts and motor assembly.

Installation - To install, reverse removal procedure.

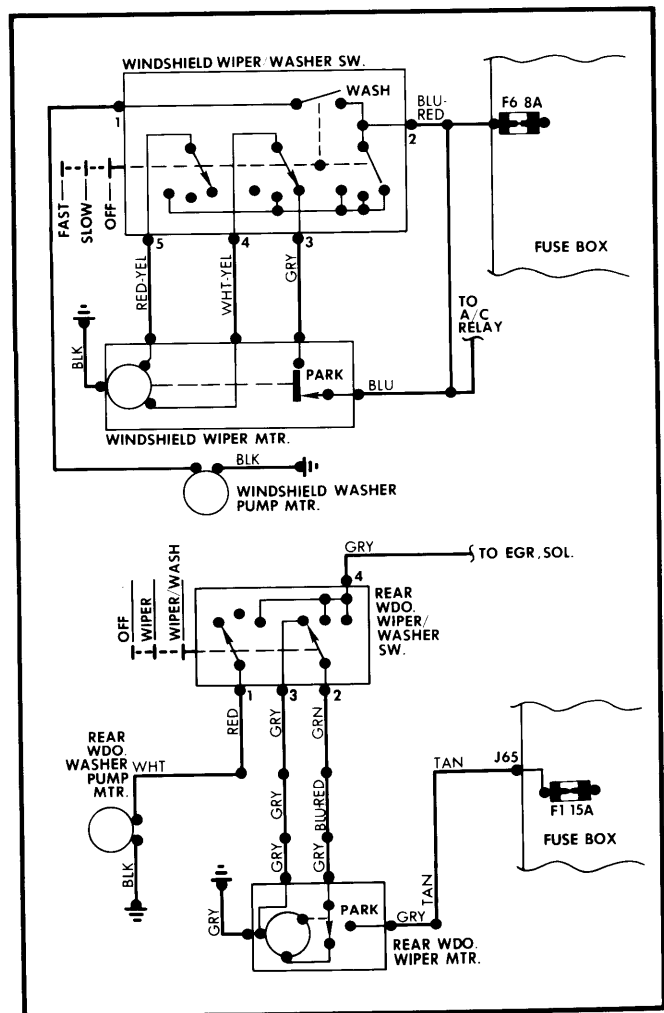

Fig. 2 Renault Le Car Wiper Wiring Diagram

Wiper/Washer Systems

RENAULT (Cont.)

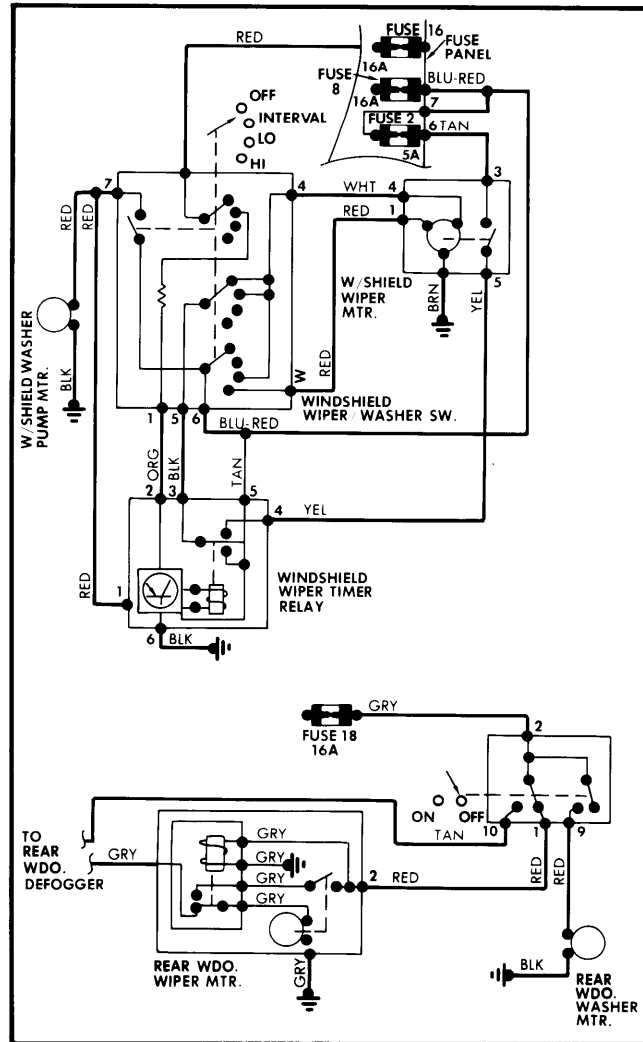

Fig. 3 Renault 18i Wiper Wiring Diagram