

## MERCEDES-BENZ

240D  
280 Series  
300 Series  
380 Series

## DESCRIPTION &amp; OPERATION

All models have a 2-speed wiper system with intermittent feature. The wipers are controlled by a steering column lever. As the lever knob is rotated, it operates the wipers at intermittent, low and high speeds. Pressing the button at the end of the lever operates the washer system. The intermittent relay is mounted on the wiper motor.

Station wagon models have a rear window wiper/washer system. This system has a low speed, intermittent speed and washer. It is controlled by 3 push buttons at the top left corner of the console. Pressing the washer button operates the washer and wiper until it is released. Pressing either of the other buttons operates the low speed or intermittent speed until the button is pressed a second time.

## REMOVAL &amp; INSTALLATION

## FRONT WIPER MOTOR

**Removal (240D, 280E, 280CE, 300D, 300CD & 300TD) —**  
1) Remove wiper arms. Remove cap and nut from wiper shafts, then remove 4 rivets and left air grille. Remove 2 screws and 4 rivets on center cover, then remove cover.

2) Pull linkage from motor crank arm. Remove water drain from right shaft. Unplug wiring and push plug through panel. Remove motor bolts and motor.

**Installation —** To install, reverse removal procedure.

**Removal (300SD & 380SEL) —** Remove wiper arms and air intake covers. Remove 3 linkage mounting bolts. Unplug wiring and push plug through panel. Remove motor with linkage. Remove motor shaft nut, then swivel linkage to one side. Remove motor bolts and motor.

**Installation —** Install motor on linkage. Place crank arm on motor shaft. Be sure that top of arm is parallel to motor centerline. See Fig. 1. Tighten shaft nut. Reverse removal procedures to complete installation.

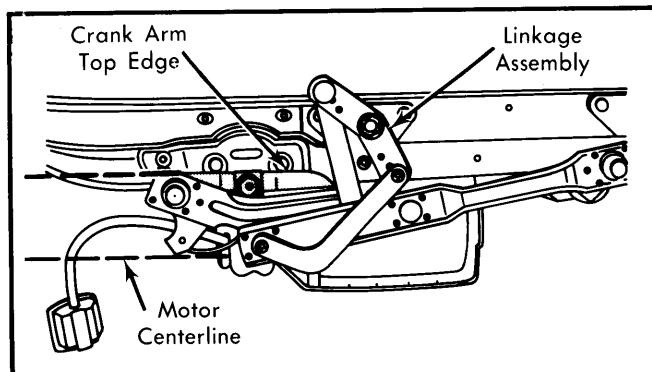

Fig. 1 Installing Motor Crank Arm Nut  
Crank Arm Must Be Parallel To Motor Centerline

**NOTE —** Removal and installation procedures for 380SL and 380SLC were not available.

## REAR WIPER MOTOR

**Removal (300TD) —** Remove wiper arm. Pull off wiper shaft sleeve. Remove inner panel trim on tailgate. Remove 2 motor assembly bolts. Pull assembly out of rubber supports, unplug wiring and remove.

**Installation —** To install, reverse removal procedure.

## WIPER SWITCH

**Removal (All Exc. 300SD & 380SEL) —** Remove rubber sleeve from switch lever. Remove 2 screws and pull switch out slightly. Take off 2 horn wires. Remove instrument panel lower cover on left side. Unplug wiring and remove switch.

**Installation —** To install, reverse removal procedure.

**Removal (300SD & 380SEL) —** Pry out steering wheel center emblem. Remove screw and discard. Remove steering wheel. Remove cover under left side of instrument panel. Unplug combination switch wiring. Remove 3 screws and combination switch.

**Installation —** To install, reverse removal procedure. Use a new steering wheel retaining screw and tighten to 60 ft. lbs. (80 N·m).

**NOTE —** Wiring diagram for rear wiper system on 300TD was not available.

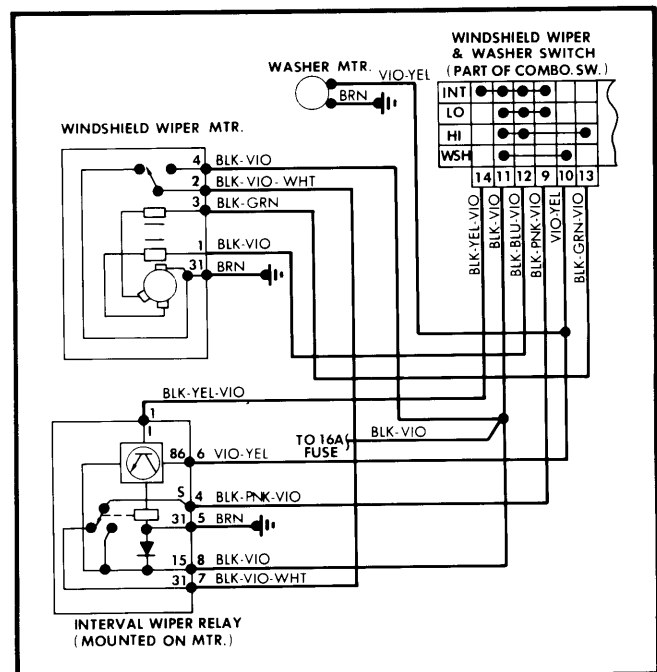

Fig. 2 Mercedes Wiper System Wiring Diagram  
(All Models)