

MAZDA

GLC
626
RX7
B2000

DESCRIPTION

All models have a 2-speed wiper motor. All except B2000 also have an intermittent wipe feature. GLC and RX7 models may be equipped with a rear window wiper/washer system. The wiper switch on all models is a lever on the side of the steering column.

A time delay relay is used to control the intermittent cycle on all except RX7 models. On RX7, a "Control Processing Unit" is used to operate a number of accessories. The wipers are also timed by this unit.

OPERATION

GLC WAGON & B2000

The wiper speeds are controlled by twisting the lever to the left of the steering column. The washer is operated by pressing in on the end of the lever. The rear wiper on GLC Wagon is turned on by pulling out the dash-mounted switch, while the washer operates when the switch is turned.

GLC HATCHBACK, RX7 & 626

The wipers are controlled by a lever on the right side of the steering column. As the lever is moved down, it switches the wipers to intermittent, low speed and high speed. If the lever is pulled toward the steering wheel, the washer sprays. If the lever is pushed away from the steering wheel, the wipers sweep until it is released. The rear wiper/washer on GLC Hatchback is controlled by a rocker switch on the instrument panel. The RX7 rear wiper switch is on the console.

TESTING

WIPER MOTOR

1) Remove wiper motor from vehicle. Connect jumper wires to connector at motor to check both speeds. For low speed, connect battery voltage to Blue wire terminal and ground the Blue/White terminal. For high speed, ground the Blue/Red terminal instead.

2) To check the park switch, apply battery voltage to the Blue wire terminal. Connect a jumper wire between Blue/White and Blue/Black. Ground the Black wire. Motor should run briefly and stop.

Mazda Intermittent Wiper Relay Locations

Model	Connector	Location
GLC	6-pin	Left of instrument cluster
RX7 [Ⓢ]	17-pin	Left kick panel
626	6-pin (4 wires)	Left kick panel, Top front relay

[Ⓢ] — Time delay is controlled by "Control Processing Unit".

3) To check rear wiper motor, apply battery voltage to Blue/Red wire and ground the Blue/White wire. Motor should run steadily.

REMOVAL & INSTALLATION

FRONT WIPER MOTOR ASSEMBLY

Removal (All Except B2000) — 1) Run wipers until they are in vertical position, then turn ignition off. Remove wiper arms and shaft nuts.

2) Remove cowl grille or access panel. Unplug connector at motor. Remove mounting bolts and wiper motor.

Installation — To install, reverse removal procedure.

NOTE — Removal procedures were not available for B2000 models.

REAR WIPER MOTOR ASSEMBLY

Removal — Disconnect battery ground cable. Remove wiper arm and shaft nuts. Remove light and service cover on rear hatch. Disconnect wiring and remove rear wiper motor.

Installation — To install, reverse removal procedure.

WIPER SWITCH

Removal — Disconnect battery ground cable. Remove steering wheel. Remove column covers and snap ring at top of column (if equipped). Unplug wiring connectors. Loosen combination switch screw. Remove combination switch.

Installation — To install, reverse removal procedure.

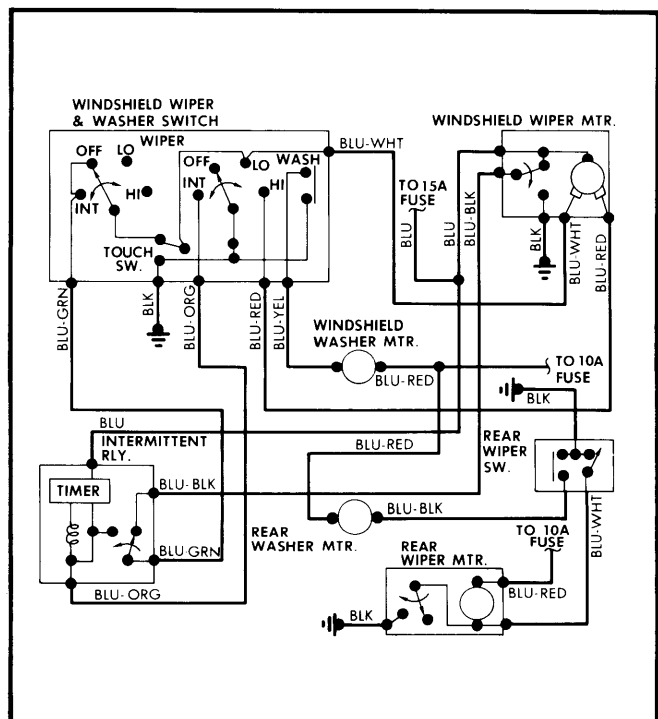

Fig. 1 Mazda GLC Hatchback Wiring Diagram

MAZDA (Cont.)

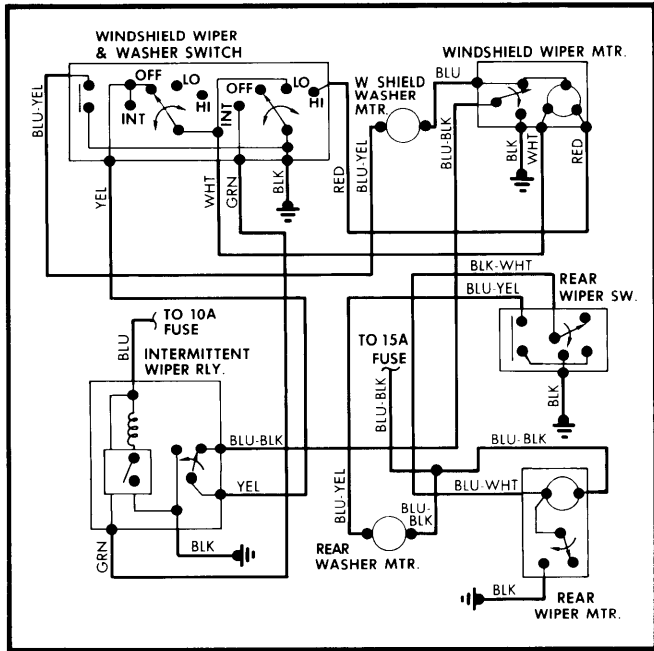

Fig. 2 Mazda GLC Wagon Wiring Diagram

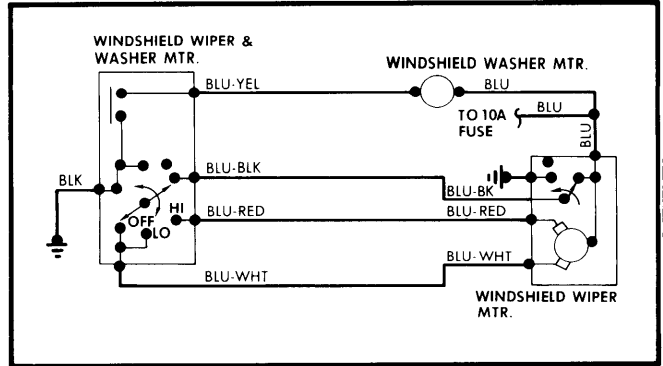

Fig. 4 Mazda B2000 Wiring Diagram

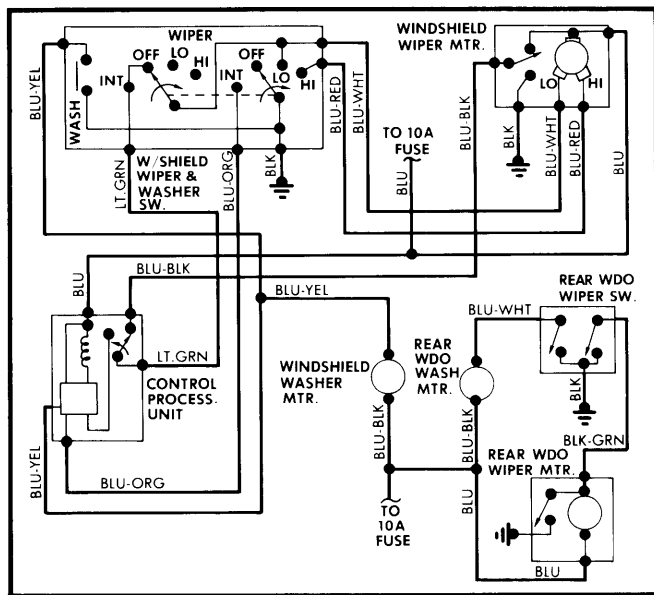

Fig. 3 Mazda RX7 Wiring Diagram

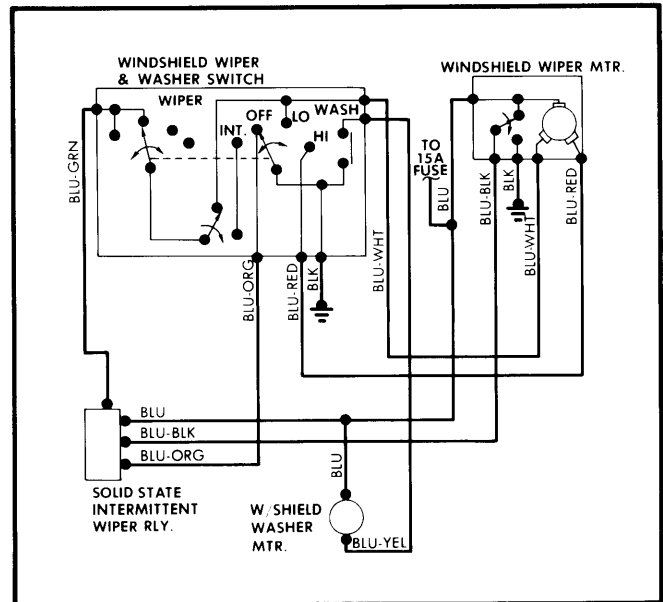

Fig. 5 Mazda 626 Wiring Diagram