

## HITACHI & MITSUBISHI

Chrysler Corp. Imports	310
Arrow	510
Arrow Pickup	810
Champ	Pickup
Challenger	Honda
Colt	Civic (Calif.)
D50 Pickup	LUV
Sapporo	Mazda
Datsun	626
200SX	GLC
210	RX7
280ZX	B2000 Pickup

### DESCRIPTION

Starter is a conventional 12-volt, 4-pole brush type motor. May be either direct or reduction gear drive. Solenoid mounted on starter shifts overrunning clutch and pinion to flywheel when starter is energized.

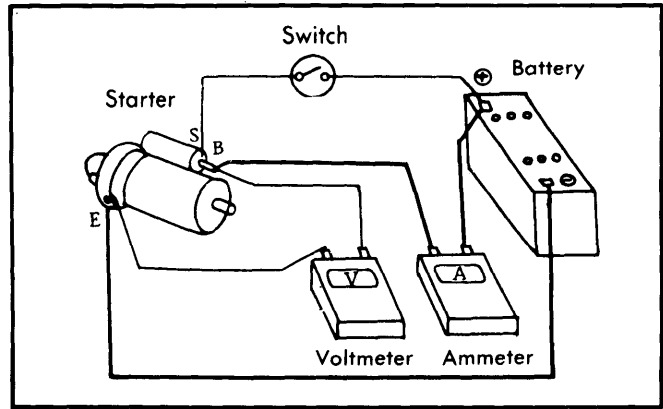

Fig. 1 Connections for No Load Test

**Lock (Torque) Test** — Mount starter in a test stand to perform torque measurement test. Follow manufacturer's instructions for test stand operation. With voltage adjusted, ammeter reading and torque should be within specifications.

### SOLENOID TESTS

**NOTE** — Make tests with solenoid removed from starter or remove solenoid lead to starter before testing. Ensure that solenoid plunger and sleeve are clean and dry before performing tests.

**Pull-In Coil Test** — Connect jumper between negative post of 12 volt battery and "S" terminal. Connect a second jumper to positive battery terminal and touch "M" (MT) terminal. Plunger should pull in immediately.

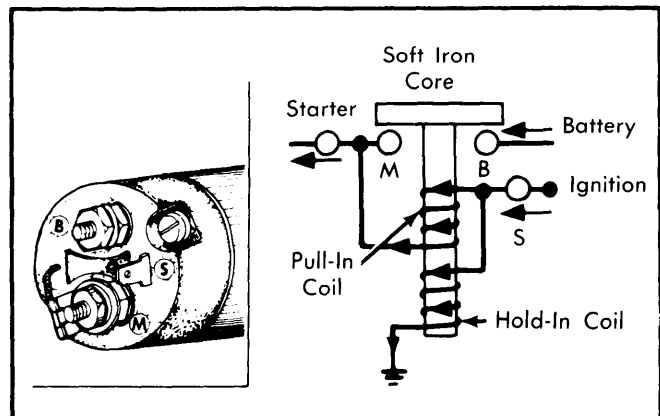

Fig. 2 Starting Circuit Diagram and Solenoid Terminals

**Hold-In Coil Test** — Connect a ground lead between the "M" (MT) terminal and the solenoid case. Apply 8 volts to the "S" terminal to pull in the plunger. Disconnect lead to "M" (MT) terminal and plunger should remain in.

**Return Test** — Push plunger into solenoid body by hand. Apply 12 volts between "M" (MT) terminal and the solenoid case. If the case is short circuited, the plunger will be attracted. If nothing happens, the solenoid is satisfactory.

### APPLICATION

#### Hitachi

Model	Type or Part No. (Mans. Trans.)	Type or Part No. (Auto. Trans.)
Datsun		
200SX	S114-180F	S114-229E
210	S114-160E	S114-163E
280ZX	S114-254D	S114-254D
310	S114-161E	
510	S114-180F	S114-229F
810	S114-254D	S114-254D
Pickup	S114-180F	S114-170E
Honda	31200 PAO 000	31200 PAO 000
LUV	⓪S114-202	⓪S114-202

⓪ — GM part number 94204438.

#### Mitsubishi

Model	Type or Part No. (Man. Trans.)	Type or Part No. (Auto Trans.)
Chrysler Corp. Imports		
1400 cc	M3T22581	
1600 cc	M3T22581	M3T25781
2000 cc	M3T25781	M2T53081
2600 cc	M3T25781	M2T53081
Mazda		
626	8088 18 400A	8964 18 400
RX7	1757 18 400D	8872 18 500A
GLC	8131 18 400	0324 18 400B
B2000 Pickup	8088 18 400A	

### TESTING

#### STARTER PERFORMANCE TESTS

**No Load Tests** — Connect starter in series with a 12 volt battery and an ammeter capable of at least a 1000 ampere reading. Connect voltmeter as shown in Fig. 1 and compare readings with *Starter Performance Specifications* as shown.

## HITACHI & MITSUBISHI (Cont.)

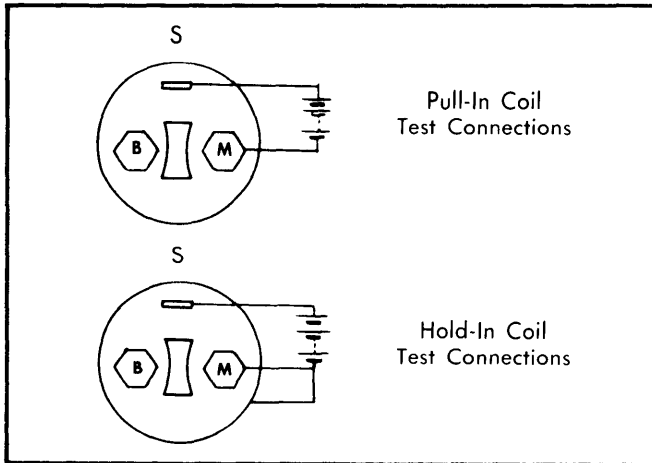

**Fig. 3 Test Connections for Pull-In Coil and Hold-In Coil**

### OVERHAUL

#### DISASSEMBLY

1) Loosen nut securing connecting plate to magnetic switch "M" terminal. Remove screws securing magnetic switch and remove switch (solenoid) assembly. Remove through bolts and brush cover assembly, then tap yoke assembly loose with wooden mallet. Remove yoke, armature assembly and pinion shift lever.

2) Remove pinion stop ring from end of armature shaft by pushing stop ring to clutch side. Remove snap ring and overrunning clutch assembly from armature shaft.

#### PARTS REPLACEMENT & TESTING

**Brushes & Springs** — Check brush spring tension using a suitable spring scale. Check brush contact surface condition and brush length. Check lead clip and wire connections and condition of brush holders. Replace as required. See *Brush Spring Tension and Brush Length (Minimum)*.

Brush Spring Tension	
Application	Lbs. (kg)
Chrysler Corp. Imports .....	3.3 (1.5)
Datsun .....	①3.1-4.0 (1.4-1.8)
Honda, LUV, Mazda .....	3.5 (1.6)

① — Reduction gear starter brush spring tension should be 3.5-4.4 lbs. (1.6-2.0 kg).

Brush Length (Minimum)	
Application	In. (mm)
Chrysler Corp. Imports & Mazda .....	.45 (11.5)
Datsun .....	①.47 (12.0)
Honda .....	.16 (4.0)
LUV .....	.47 (12.0)

① — Reduction gear starter minimum length should be .043" (11.0 mm).

**Armature** — Check external condition of armature for scoring or other damage. Measure shaft distortion with dial indicator. Replace armature if shaft bend exceeds .003" (.08 mm) on Datsun, .006" (.15 mm) on LUV, and .004" (.10 mm) on all other models.

**Commutator** — Inspect commutator for roughness, grooves, burns or pitting. Sand lightly with 500 grit sandpaper if necessary. Check commutator for out-of-round and mica insulators undercut to a depth of .020-.031" (.5-.8 mm). If necessary, commutator may be turned less than .04" (1 mm) from original size and mica undercut. Replace if excessively worn.

**Field Coil** — Check field coil continuity by connecting test probe of circuit tester or an ohmmeter to the field coil positive terminal and brush holder. If circuit is open, replace field coil. Check for grounding of field coils by placing one probe of circuit tester on starter housing and other probe to field coil positive terminal. If little or no resistance, field coil is grounded and must be replaced.

**Overrunning Clutch Assembly** — Inspect pinion assembly and sleeve. Sleeve should slide freely on armature shaft and spline. If damage or resistance is noted, replace assembly. Check pinion and flywheel teeth for excessive rubbing or damaged teeth. Replace as required.

**Pinion Gear Clearance** — The clearance between the pinion gear and stop collar should be .012-.059" (.30-1.52 mm) on Hitachi and .02-.08" (.51-2.03 mm) on Mitsubishi when solenoid is engaged. Adjust as necessary by changing shims between solenoid and starter yoke. See Fig. 4.

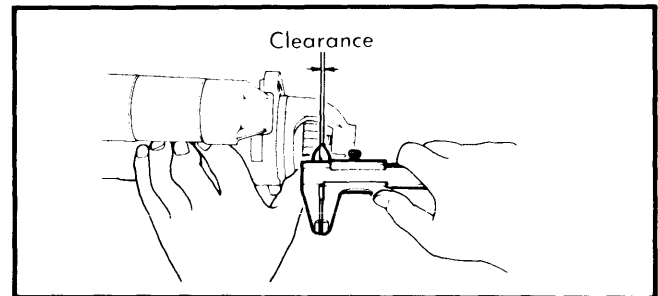

**Fig. 4 Measuring Pinion Edge-to-Pinion Stopper Clearance**

**Pinion Case Bearing** — Inspect bearing for wear and check side play. If clearance exceeds .008" (.2 mm), replace bearing. New bearing clearance should be .001-.004" (.025-.10 mm) for Hitachi or .002-.004" (.05-.10 mm) for Mitsubishi starters.

**NOTE** — Ensure that bearing is installed so that end of bearing is flush with gear case end.

#### CLEANING & INSPECTION

Clean all disassembled parts. Do not use grease dissolving solvent on overrunning clutch, armature assembly, solenoid assembly or field coils due to possible damage. Inspect all parts for damage or wear and replace as required.

#### REASSEMBLY

To reassemble, reverse disassembly procedure. **Fill rear case** on reduction gear models with grease. **Lightly oil pinion** and all bearing surfaces.

## HITACHI & MITSUBISHI (Cont.)

STARTER PERFORMANCE SPECIFICATIONS					
Type or Part No.	No Load Test		Load Test		
	Amps. (Maximum)	RPM	Amps. (Maximum)	Volts	Torque (Ft. Lbs.) (Minimum)
<b>HITACHI</b>					
S114-160B	60	7000	.....	.....	.....
S114-161E	60	7000	.....	.....	.....
S114-163E	60	7000	.....	.....	.....
S114-170E	60	7000	.....	.....	.....
S114-180F	60	6000	.....	.....	.....
S114-202	60	6000	330	5.0	5.8
S114-229E & F	60	7000	.....	.....	.....
S114-254B	100	3900	.....	.....	.....
31200-PAO-000	70	6000	200	8.0	3.3
<b>MITSUBISHI</b>					
M2T 53081	90	3300	.....	.....	.....
M3T 22581	53	6800	.....	.....	.....
M3T 25781	60	6600	.....	.....	.....
O324 18 400B	53	6800	310	5.0	5.4
1757 18 400D	50	5600	600	5.0	6.9
8088 14 400A	53	6800	310	5.0	5.4
8131 18 400	53	6800	310	5.0	5.4
8872 18 400A	100	6600	1050	5.0	15.9
8964 18 400	60	6600	500	5.0	8.3

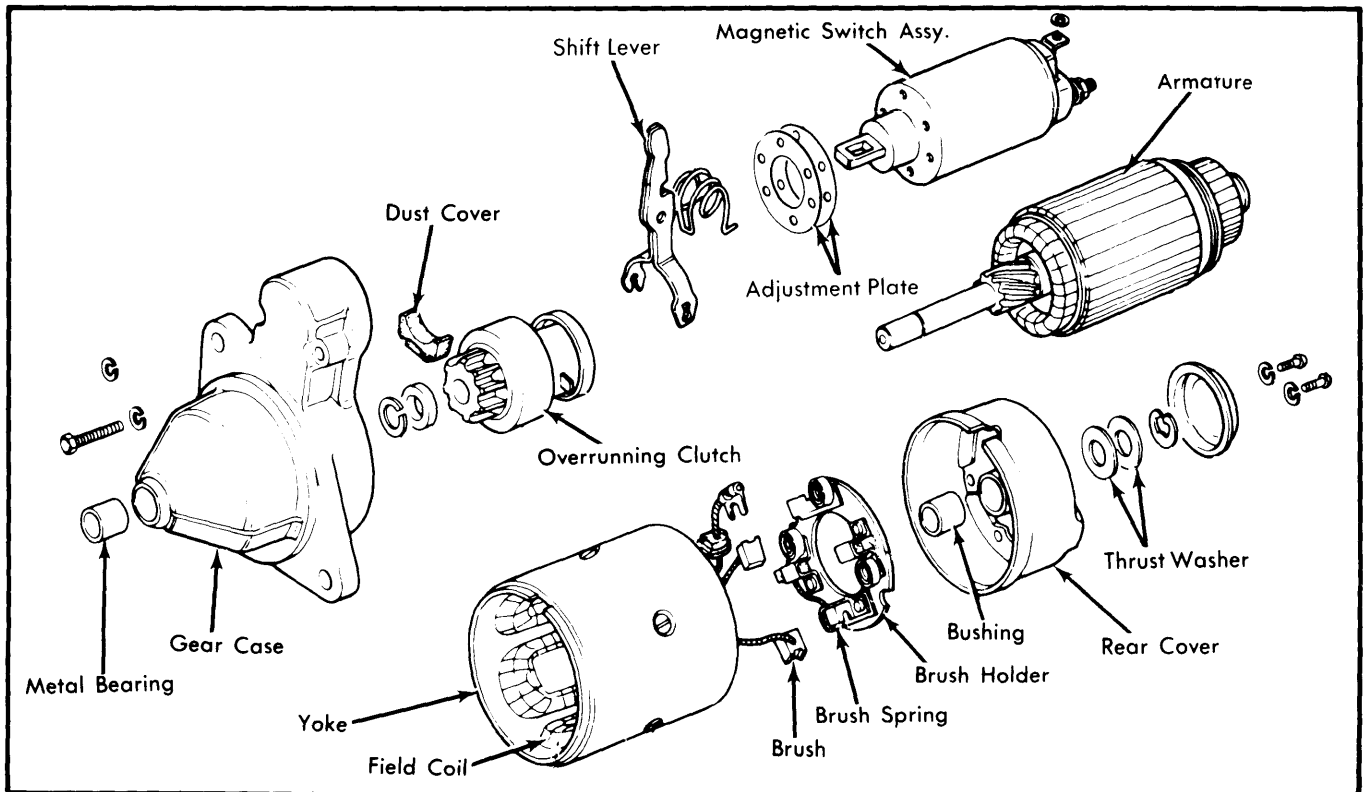

**Fig. 6 Disassembled View of a Typical Hitachi Starter**