

NIPPONDENSO REGULATORS

Honda
Accord
Civic
Prelude
Toyota
Celica

Corolla
Corona
Cressida
Land Cruiser
Pickup

DESCRIPTION

Nippondenso regulators may be either single or double element type. Single element type has a voltage regulator element only while 2 element type has both voltage regulator and a voltage warning relay. Single element type is normally fitted to units with an ammeter, while double element type normally has a charge warning light.

APPLICATION

Model	Part No. ①
Honda (All Models)	SAO 672
Toyota	
Celica	27700 38100
Corolla	27700 26030
Corona	27700 38100
Cressida	27700 41050
Land Cruiser	27700 24020
Pickup	27700 38120

① — Vehicle manufacturer part number. Some regulators are integrated circuit (IC) type. Part number furnished for information only.

TESTING

VOLTAGE REGULATOR

NOTE — Substitution of a known good regulator for one suspected of malfunctioning will frequently save time during testing.

Toyota — Disconnect wire from "B" terminal of alternator and connect to negative of ammeter. Connect test lead from ammeter positive terminal to "B" terminal of alternator. With engine running at varying speeds from idle to 2000 RPM, voltage should be 13.8-14.8 volts and amperage should be less than 10 amps. If not within specifications, adjust or replace regulator as required. See **ADJUSTMENT**.

NOTE — If a battery/alternator tester is available, connect and test according to tester manufacturer's instructions.

Honda — Connect voltmeter across battery terminals and ammeter between positive terminal and main fuse. (Main fuse wire from battery disconnected.) Ensure that all lights and accessories are OFF and disconnect negative cable from battery with engine idling. Vary engine speed from 2000 to 4000 RPM and note voltage reading between 13.5 and 14.5 volts. If not within specifications, adjust or replace regulator as required. See **ADJUSTMENT**.

CAUTION — If engine stops when battery negative cable is removed, DO NOT attempt to restart engine until cable is connected.

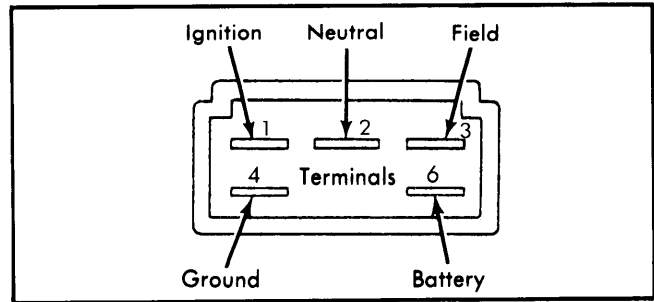

Fig. 1 Terminal Positions for Honda Connector

ADJUSTMENT

NOTE — Adjustments are not applicable to sealed units. If points are slightly oxidized or pitted, dress contacts with sandpaper (400 grit or finer). If points are oxidized or pitted excessively, replace regulator assembly.

Voltage Relay — Connect voltmeter between "N" terminal (white wire) and ground then increase engine speed gradually. Voltmeter reading should be 4.0-5.8 volts when indicator light goes out. Adjust cut-in voltage by adjusting armature core gap and point gap using following procedures.

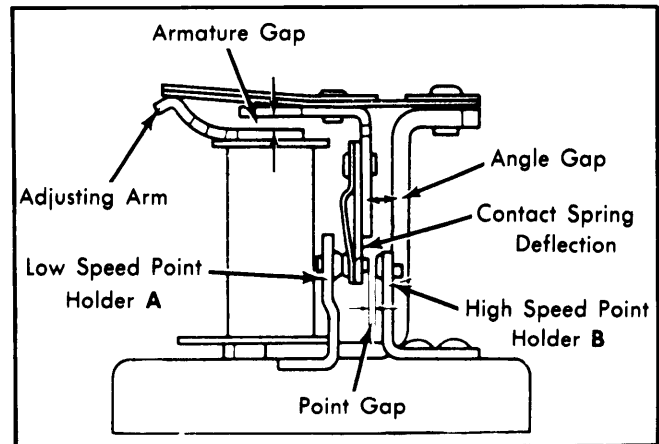

Fig. 2 Adjustments for Voltage Relay

1) If cut-in voltage is too high, adjust by bending core adjusting arm down. Bend arm up if cut-in voltage is too low.

2) If adjustment of core arm does not correct cut-in voltage, proceed with point gap adjustment. Disconnect negative cable from battery. Check armature core gap with armature depressed until moving point is in contact with "B" side point. Armature core gap should be .012" or more. Adjust by bending point arm "B".

3) Release the armature and adjust the gap between the "B" side point and the moving point by bending point arm "A". Point gap should be .016" to .047".

4) After point gap adjustment, recheck cut-in voltage. If not within 4.0-5.8 volts, repeat cut-in voltage adjustment.

Voltage Regulator — If the no load regulated voltage is not within the 13.8-14.8 volt range, adjust regulator as follows:

1) If regulated voltage is too high, adjust by bending armature adjusting arm down. If voltage is too low, bend arm up.

NIPPONDENSO REGULATORS (Cont.)

2) If core arm adjustment will not correct regulated voltage, proceed to point gap adjustment.

3) Disconnect battery ground cable. Depress armature arm until the moving point contacts "B" side point. Bend point arm "B" to obtain armature gap of .012" or more.

4) Release armature and adjust gap between "B" side point and moving point by bending point arm "A". Gap should be .012" to .018".

5) After gap adjustment is made, recheck no load regulated voltage under operating test. Repeat core arm adjustment if necessary.

NOTE — Regulator cover must be installed after adjustments prior to further testing.

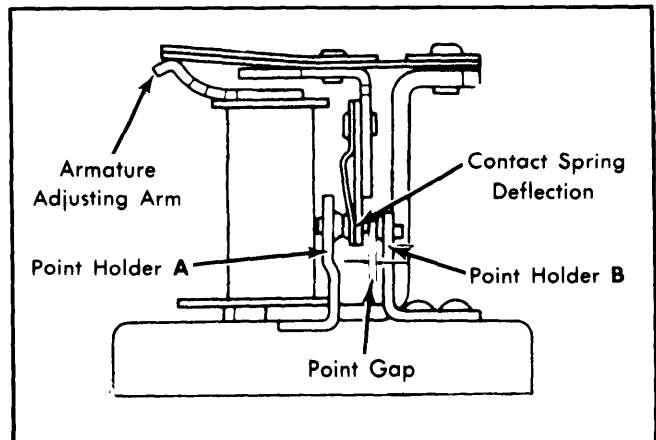

Fig. 3 Adjustments for Voltage Regulator