

## MITSUBISHI REGULATORS

Courier  
Mazda

### DESCRIPTION

Regulator consists of a constant voltage relay and a pilot lamp relay. Both relays consist of an electromagnet, contacts, frame, moving element and coil side plate. This regulator has a temperature compensation gradient incorporated to automatically lower the adjusted value of the constant voltage relay in warm weather and to increase it in cold temperatures.

### APPLICATION

Model	Part. No.
Courier .....	D97Z-10316-A
Mazda .....	8914 18 391

### TESTING

**CAUTION** — Ensure that voltage regulator protecting fuse is functional before conducting any charging system diagnosis. Verify condition by substituting known good fuse.

To check adjusted value of constant voltage relay, connect a voltmeter between terminal "A" and "E" of the regulator. Place generator at no load by disconnecting one of the battery terminals during operation at idling speed, then increase alternator speed to approximately 4000 RPM (Approximately 2000 engine RPM). In this condition, satisfactory voltage is 14.5-15.8 volts.

### ADJUSTMENT

**NOTE** — Adjustment procedures furnished for Mazda only. Manufacturers recommend installation of new regulator when tolerance not within limits for other models.

Adjust voltage of the constant voltage relay by bending end of coil side plate up or down as shown in illustration. If plate is bent up, the adjusted value becomes higher. If it is bent down, value becomes lower. Adjust pilot lamp relay by same method.

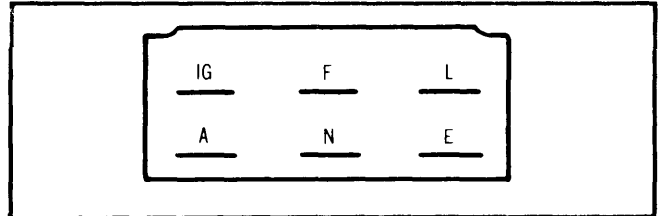

Fig. 1 Regulator Harness Connector

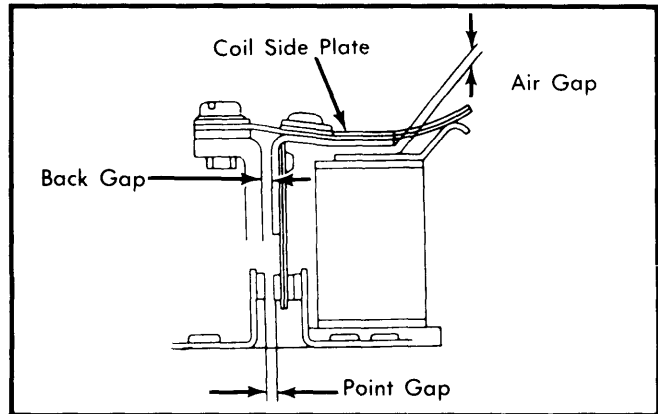

Fig. 2 Voltage Adjustment Point

### MITSUBISHI ALTERNATOR REGULATOR SPECIFICATIONS

Reg. No.	VOLTAGE REGULATOR				PILOT LAMP RELAY		
	Output Volts	Air Gap in. (mm)	Back Gap in. (mm)	Point Gap in. (mm)	Air Gap in. (mm)	Back Gap in. (mm)	Point Gap in. (mm)
891418391	14-15	.028-.051 (.71-1.3)	.028-.059 (.71-1.5)	.012-.018 (.31-.45)	.039-.059 (1.0-1.5)	.028-.059 (.71-1.5)	.020-.035 (.71-1.1)