

## HITACHI REGULATORS

LUV  
Subaru

### DESCRIPTION

Regulator system consist of a voltage regulator and a charge relay. The voltage regulator has 2 sets of contact points to control alternator voltage. An armature plate placed between the 2 sets of contacts moves upward, downward, or vibrates. The lower contacts, when closed, complete the field circuit direct to ground. The upper contacts complete the field circuit to ground when closed, through a resistance (field coil), causing the alternator to charge. The charge relay is similar in construction to the voltage regulator. When upper contacts are closed, the ignition warning light goes on.

### APPLICATION

Model	Hitachi No.
LUV .....	TLIZ-87
Subaru .....	TLIZ-94E

### TESTING

#### VOLTAGE REGULATOR

1) Connect voltmeter and ammeter as illustrated. Start and maintain engine speed at 2500 RPM for a few minutes, then check that ammeter reading is 5 amps or less. If ammeter remains higher than 5 amps, disconnect battery in use and connect a battery known to be fully charged. Recheck to ensure that ammeter reading is less than 5 amps.

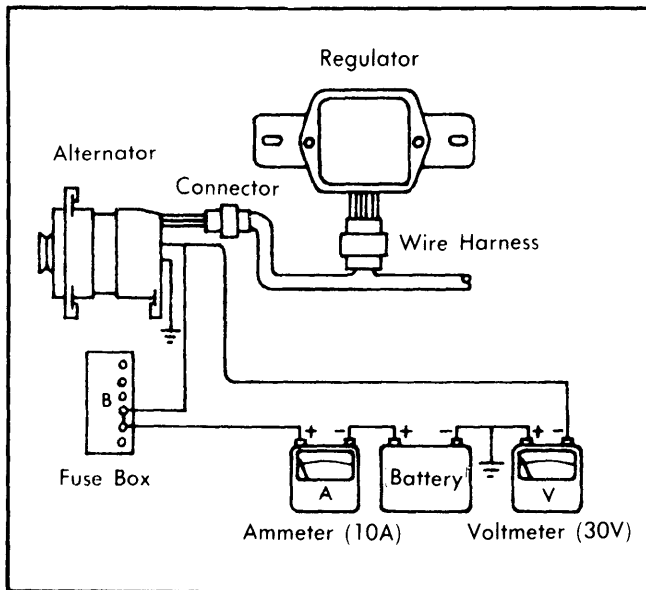

Fig. 1 Test Connections for Voltage Regulator

2) Lower engine speed to idle and again increase it gradually to 2500 RPM, then note voltmeter reading. Function of regulator is normal if measured value is within specified regulating voltage. If voltmeter reading deviates from specified range, regulator is in need of adjustment.

### ADJUSTMENT

**NOTE** — Charge relay is adjusted in same manner as voltage regulator.

1) Disconnect and remove voltage regulator from vehicle. If contact points are roughened, smooth with fine sandpaper. Check and adjust core gap first, then point gap. Yoke gap adjustment may be unnecessary on some models.

2) Adjust core gap by loosening screws attaching contact set to yoke. Move contact set upward or downward as required. Adjust point gap by loosening screw attaching upper contact. Move upper contact up or down as required to set gap to specification.

3) Adjust regulated voltage by means of adjusting screw. Turn screw in to increase regulated voltage or out to decrease voltage. When correct voltage adjustment is obtained, secure with lock nut. When adjustment procedure is complete, reinstall regulator and perform on car check.

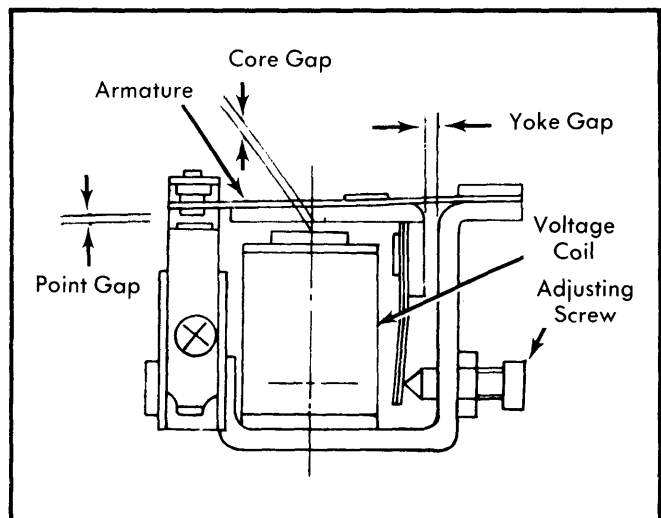

Fig. 2 Adjustment Points for Charge Relay

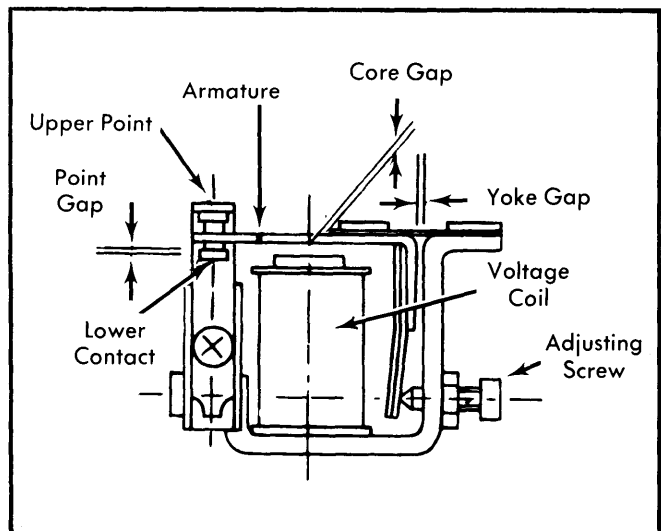

Fig. 3 Adjustment Points for Voltage Regulator

## HITACHI REGULATORS (Cont.)

VOLTAGE REGULATOR SPECIFICATIONS						
Regulator	Battery Voltage	Regulated Voltage	Voltage Coil Resistance (Ohms)	Yoke Gap In. (mm)	Core Gap In. (mm)	Point Gap In. (mm)
TLIZ-87	12	13.8-14.8	10.3	①	.024-.039(.6-1.0)	.012-.016 (.30-.40)
TLIZ-94E	12	14.0-15.0	10.3	.035(.9)	.024-.039(.6-1.0)	.014-.018 (.35-.45)

① — No yoke gap adjustment required.

VOLTAGE RELAY SPECIFICATIONS					
Regulator	Released Voltage	Voltage Coil Resistance (Ohms)	Yoke Gap In. (mm)	Core Gap In. (mm)	Point Gap In. (mm)
TLIZ-87	5②	31.9	①	.032-.039(.8-1.0)	.016-.024(.41-.61)
TLIZ-94E	8-10	32.1	.035(.9)	.032-.039(.8-1.0)	.016-.024(.41-.61)

① — No yoke gap adjustment required.

② — Measured at "A" terminal.