

HITACHI ALTERNATORS

Datsun (With IC Regulator)
LUV
Subaru

DESCRIPTION

Hitachi alternators are conventional 3 phase, self rectifying type alternators. Six diodes (3 positive and 3 negative) are used to rectify current.

APPLICATION

Model	Hitachi Type No.
Datsun	
200SX	LR160-47
210	LR150-36
310	LR160-46
510	LR150-52
280ZX & 810	LR160-42B
Pickup	
Standard	LR135-44
Heavy Duty	LR138-01
LUV	LT135-30
Subaru	
Exc. Sta. Wagon	LT150-113
Station Wagon	LT150-114B

SPECIFICATIONS

Output@2500 Alternator RPM

Alternator	Amps	Volts
LT135-30	28	14
LT135-44	27.5	14
LR138-01	30	14
LR150-36	40	14
LR150-52	40	14
LT150-113	42	14
LT150-114B	50	14
LR160-42B	50	14
LR160-46	45	14
LR160-47	45	14

Nominal Output@5000 Alternator RPM

Alternator	Amps	Volts
LT135-30	35	12
LT135-44	35	12
LR138-01	38	12
LR150-36	50	12
LR150-52	50	12
LT150-113	50	12
LT150-114B	55	12
LR160-42B	60	12
LR160-46	60	12
LR160-47	60	12

TESTING

NOTE — Some testing is described as part of Overhaul procedure in this article. The following testing is performed with alternator on the vehicle.

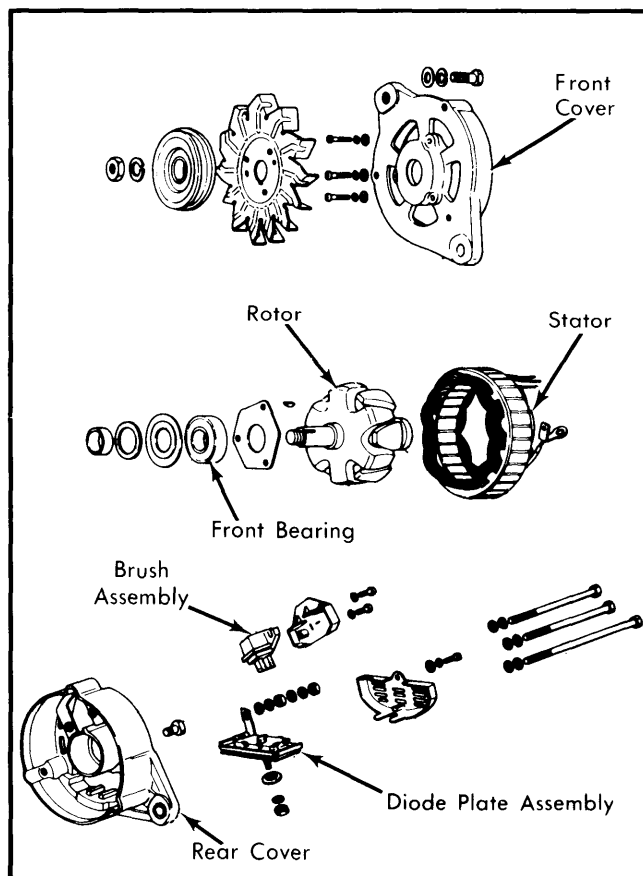

Fig. 1 Disassembled View of Typical Hitachi Alternator

ALTERNATOR TEST ON VEHICLE

Datsun Models — Ensure that battery has a full charge, then connect 30-volt voltmeter as illustrated in Fig. 2. Turn ignition switch "ON" and test as follows:

1) If charge light remains OFF, disconnect connector from rear of alternator and ground "L" lead wire. If light remains OFF, replace indicator bulb. If light is ON, reconnect connector and ground "F" terminal by touching brush with grounded wire. If light stays on, replace IC regulator. If light goes out, remove and repair alternator.

2) If light came ON when ignition was turned "ON", start and idle engine. If light is dim, flickers or remains bright, remove and repair alternator. If light went off at idle, run engine at 1500 RPM and turn headlights on high beam. If charge light is on dim, idle engine and measure voltage between terminals "B" and "L". If less than .5 volt, alternator is OK. If more than .5 volt, remove and repair alternator.

NOTE — Terminals "S", "L", "BAT" and "E" are marked on rear cover of alternator.

3) If charge light went OFF at 1500 RPM with lights on high beam, measure "B" voltage. If more than 15.5 volts, replace IC regulator. If 13 to 15 volts, idle engine and check indicator light. If OFF, system is OK. If ON, repair faulty alternator.

Alternators & Regulators

HITACHI ALTERNATORS (Cont.)

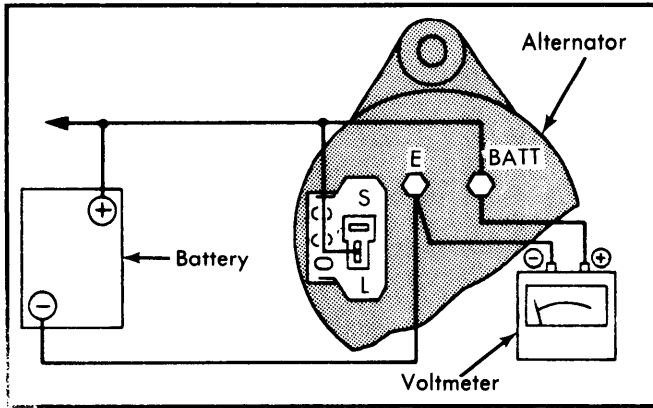

Fig. 2 Alternator Testing Connections for Datsun

Subaru Models — 1) Connect a voltmeter and leads to battery as shown in Fig. 3. Operate the alternator and turn off the switch "SW" when alternator speed reaches approximately 800 RPM. Increase speed in small increments while watching voltmeter deflection and read alternator speed when at 14 volts. Speed should be approximately 1000 RPM.

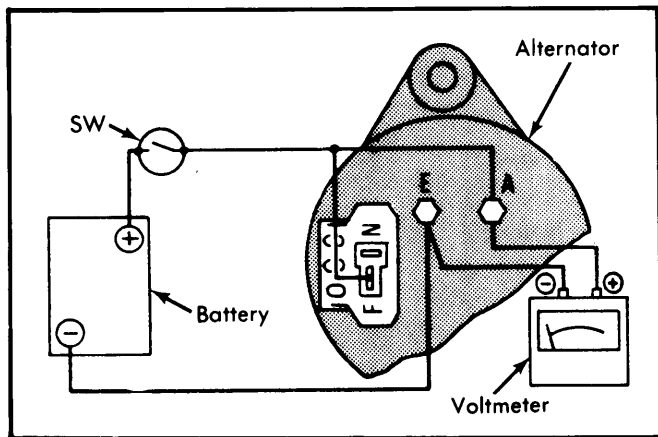

Fig. 3 Alternator Cut-In Speed Test Connections (Subaru)

2) Make test connections using a 30-50 ampere variable resistor, battery, ammeter, and voltmeter as shown in Fig. 4. Operate alternator with switch "SW-1" closed. When alternator speed reaches approximately 800 RPM, set the variable resistor to maximum and turn on switch "SW-2". Increase alternator speed while maintaining a constant 14 volts by adjusting resistance. Read current at 2500 RPM and 5000 RPM. Readings should be 37-43 amperes at 2500 RPM and 48-54 at 5000 RPM.

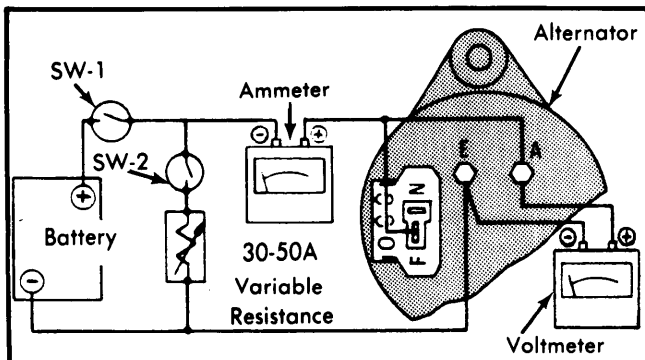

Fig. 4 Alternator Output Test Connections for Subaru

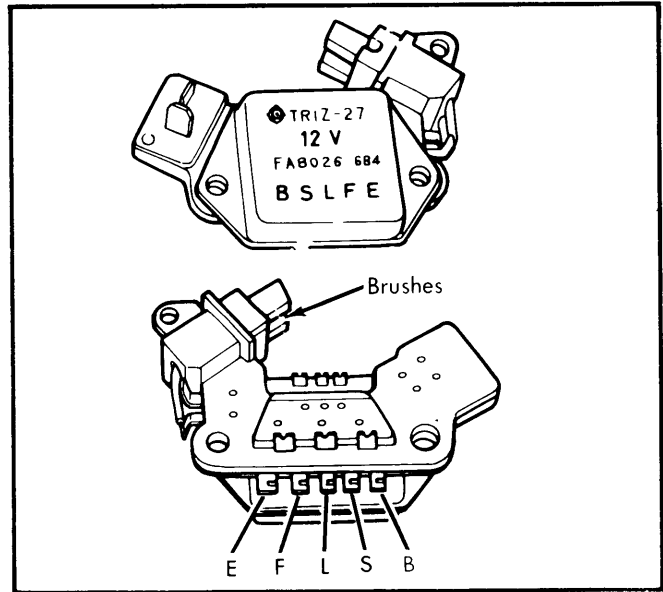

Fig. 5 Front and Rear Views of IC Regulator (Datsun)

RESISTANCE & CONTINUITY TESTING

All Models — 1) Measure resistance, using an ohmmeter, across "F" and "E" terminals for rotor coil resistance. Rotor coil circuit is normal if resistance is 4-5 ohms. If resistance is high, there is poor contact between brushes and commutator. If no continuity exists between "F" and "E" terminals, there is either an open rotor coil circuit, brush sticking or a broken lead wire. If resistance is low, it indicates a rotor coil layer short or grounded circuit.

NOTE — The following test will not indicate an open state of the diodes. Tester will indicate continuity regardless of diode conditions if tester leads are connected to the terminals with polarity reversed.

2) Connect positive lead of tester to alternator "N" terminal, and tester negative lead to alternator "A" terminal. If tester shows continuity, one or more positive diodes are shorted.

3) Next, connect positive lead of tester to alternator "E" terminal, and tester negative lead to alternator "N" terminal. If continuity is indicated, one or more of the negative diodes are shorted.

INTEGRATED CIRCUIT (IC) REGULATOR

An integrated circuit regulator is used on all Datsun models. The voltage regulator is soldered to the brush assembly and mounted inside the alternator.

Testing — 1) Remove brush assembly and with suitable tester, connect wiring as shown in Fig. 6. If V-1 voltage is not within 10-13 volts, charge or replace battery as necessary. Disconnect lead at terminal "S" and check voltage between terminals "F" and "E". If less than 2.0 volts, regulator is functioning properly.

2) Measure total voltage (V-3) of batteries 1 and 2. If not within 20-26 volts, recharge or replace. Gradually decrease variable resistance (Rv) from 300 ohms and check voltage (V-2) between terminals "E" and "F". At some point, V-2 should increase to equal V-1 measured in step 1). If no V-2 variation occurs as described, regulator is defective.

HITACHI ALTERNATORS (Cont.)

3) Measure voltage (V-4) between center tap of variable resistor (Rv) and terminal "E". With resistance set as in previous step, voltage should be $14.7 \pm .5$ volts at 68°F (20°C). At extremely high case temperatures, voltage may be 1 volt lower, while at extremely cold temperatures, voltage may be 1 volt higher.

4) Remove test lead from terminal "S" and connect to terminal "B". Repeat steps 2) and 3) and check for voltage (V-4) .5-2.0 volts higher than in step 3). If testing specifications are not met, it will be necessary to replace the IC regulator/brush assembly.

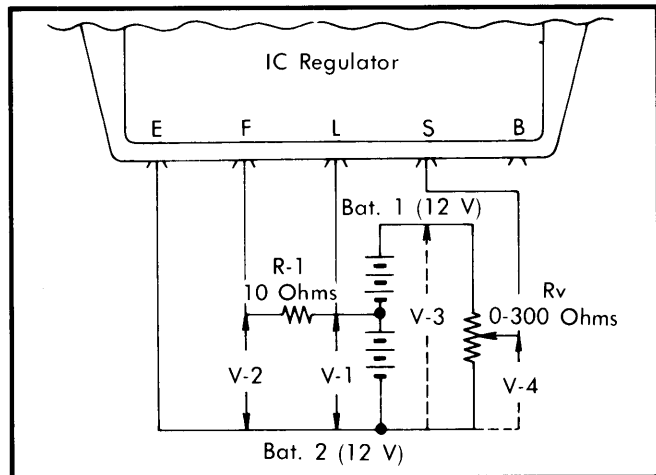

Fig. 6 Regulator Test Arrangement

OVERHAUL

DISASSEMBLY

1) Remove nut and take off pulley, fan, and washers. Pull out spacer. Remove screws securing brush holder and brush holder cover, leaving "N" lead wire connected to stator coil lead.

2) Unscrew through bolts and separate front and rear housings. Remove 3 set screws from bearing retainer and separate rotor from front cover. Pull rear bearing from rotor assembly if replacement is required.

3) Remove diode cover and disconnect stator coil lead wire from diode terminal using a soldering iron. Remove the diode assembly by unscrewing the terminal nut and diode setting nuts. Remove stator from rear cover.

INSPECTION & REPAIR

Rotor — Apply tester to slip rings of rotor. If ohm reading is within specifications, rotor conduction is satisfactory. If not, an open connection to the field coil may exist. Next, apply probes to slip ring and rotor core to check for ground. If conduction exists, replace rotor assembly.

Stator — The stator is normal when there is conduction between individual stator core terminals. When there is no conduction between terminals, cable is broken and stator must be replaced. If each lead wire of stator coil (including neutral wire) is not conductive with stator core, condition is satisfactory. If conduction exists, stator is grounded and must be replaced.

Diodes — 1) Perform a conduction test on all diodes in both directions using an ohmmeter. Test the conduction between

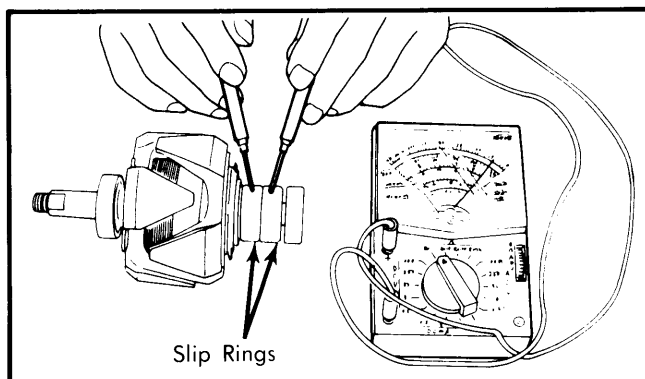

Fig. 7 Rotor Field Coil Conduction Test

each terminal and plate. Diode installed on a "+" plate is a positive diode which allows current to flow from terminal to "+" plate only. Current does NOT flow from "+" plate to the terminal. A diode installed on the "-" plate is a negative diode and allows current to flow from the "-" plate to the terminal only. Current does NOT flow from the terminal to the "-" plate.

2) If current flows in both directions, the diode is shorted. If current does not flow in either direction, the diode is open. If any diode is defective, replace the entire diode assembly (individual diodes are not serviceable).

Brushes & Brush Springs — Inspect brushes for freedom of movement in holder. Clean brush holder if necessary. Check brushes for cracks and wear; replace if beyond limits (.28" or 7.0 mm for LT135-30, LT150-21 and LR160-42; .30" or 7.5 mm for all others). Check brush springs for corrosion, damage and proper tension (9-12.2 oz. with .08" or 2 mm protrusion from holder). Test brush holder to assure that no continuity exists between holders; replace if required.

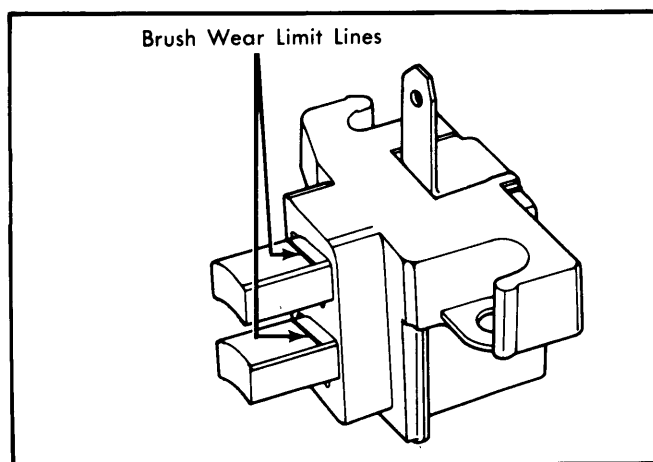

Fig. 8 Brush Assembly with Wear Indicators

REASSEMBLY

Reinstall diode assembly and stator to rear cover. Connect lead wires of stator coil to terminals of diode assembly. Reinstall diode cover. Reinstall rotor to front cover. Place assembly in vise and replace pulley and components. Insert and tighten housing through bolts. Assemble brushes to brush holder and insert holder into alternator.

NOTE — Soldering must be done quickly to avoid damage to diodes.