

MOTORCRAFT ALTERNATORS

Fiesta

DESCRIPTION

Alternator is belt driven from engine. An external regulator controls charging rate by switching rotor field current in and out as required through brushes contacting slip rings. Alternating current is produced and converted to direct current by the diode rectifier assembly.

IDENTIFICATION & SPECIFICATIONS

Alternator is stamped with "Motorcraft" trademark in either orange or green.

APPLICATION

Color	Rating	RPM (Hot)
Orange	40 Amps @ 15 V	2900
Green	60 Amps @ 15 V	2900

TESTING

FUSE LINK

Fuse links are provided in the charging system to prevent damage to the harness and alternator in case the harness becomes grounded or a booster battery is connected with reverse polarity. Insulation which is rippled or bubbled indicates that the link is blown and must be replaced. In case of vehicles with two fuse links, check the accessories link by turning headlamps or an accessory on. If fuses are not blown and they still fail to function, the link is probably blown and must be replaced.

INDICATOR LIGHT

Warning light should come on when starting engine and go off after engine is idling. If no light, check bulb and replace if burned out. If bulb is not burned out check for open circuit between switch and regulator. If light does not go out until engine reaches high RPM, check 15 ohm resistor connected in parallel with light.

VOLTAGE OUTPUT TEST

1) Attach voltmeter to battery and record voltage. Start engine and increase engine speed to 1500 RPM when normal operating temperature is reached. With NO electrical load on system, voltage should increase to at least 1 volt but not more than 2 volts above original reading.

2) Turn on heater blower motor to high speed and headlights to high beam. Increase engine speed to 2000 RPM and note battery voltage at least 0.5 volt above original reading with engine off.

3) If no-load voltage in step 1) exceeds 2 volts, assure that ground connections between regulator, alternator and engine are tight. Disconnect wiring plug from regulator and recheck no-load voltage. If voltmeter now indicates battery voltage throughout the test, replace voltage regulator and recheck.

4) If voltage increase is excessive with regulator disconnected, repair shorted wiring harness between alternator and regulator.

NOTE — If harness is shorted, regulator will have been damaged and must be replaced.

5) If load voltage in step 2) did not increase or increase was less than 0.5 volt, check battery voltage at alternator "BAT" terminal. Disconnect regulator plug and check battery voltage at "A" terminal. If no voltage present at these terminals, repair wiring and repeat output test.

6) If battery voltage is present at both "BAT" and "A" terminals, connect jumper across "A" and "F" terminals of regulator plug. If field circuit is grounded, jumper will spark and heat. Check field circuit for ground and regulator for open before continuing.

7) To check field circuit, measure resistance between "F" terminal on regulator plug and negative battery cable clamp. Ohmmeter should read between 4 ohms and 250 ohms. No resistance indicates that the field circuit is grounded and requires alternator removal and repair.

8) Check resistance between "I" and "F" terminals with plug removed. Ohmmeter should indicate zero resistance. A reading of 10 or more ohms indicates an open connection in the regulator. Replace regulator and repair alternator field circuit.

9) If load voltage is still less than specified, remove jumper from regulator wiring plug and install a jumper between alternator "BAT" and "FLD" terminals. Repeat output test. If results are satisfactory, wiring harness is at fault and must be repaired or replaced. If load voltage increase is still less than 0.5 volt, alternator must be removed from vehicle for bench testing.

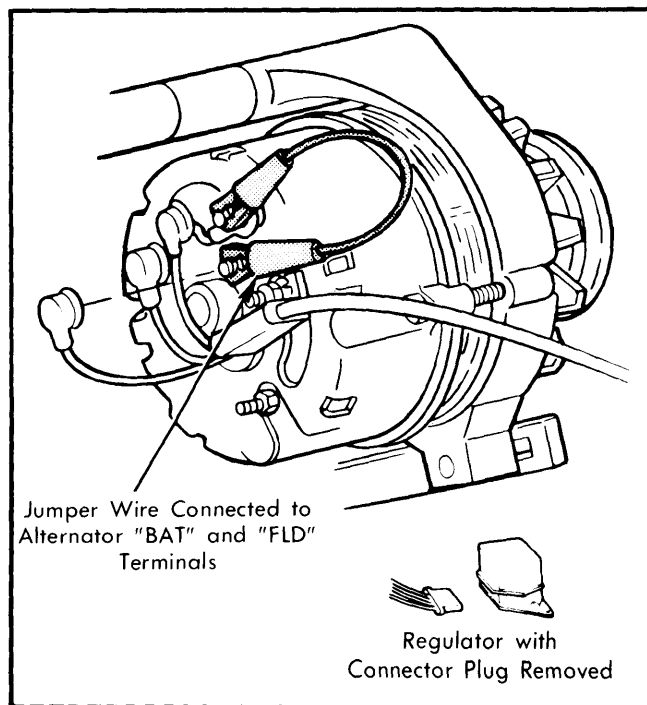

Fig. 1 Alternator with Jumper for Testing

MOTORCRAFT ALTERNATORS (Cont.)

OVERHAUL

DISASSEMBLY

- 1) Scribe mark across front and rear housings and stator for alignment during reassembly. Remove through bolts and separate front housing and rotor from rear housing and stator.
- 2) Remove terminal nuts and insulators from rear housing and separate stator/rectifier assembly from housing. Remove brushes and brush holder.
- 3) To remove stacked type rectifier, remove stator terminal screw and grounded screw by turning them $\frac{1}{4}$ turn to unlock from rectifier. Unsolder leads from rectifier using caution not to overheat rectifier assembly. To remove flat type rectifier, remove stator terminal screw by pressing straight out of rectifier. Do NOT turn screw or remove grounded screws. Unsolder leads from rectifier.
- 4) Remove front pulley and fan, then separate rotor from housing and bearing. Bearing may be replaced by removing retainer screws and retainer.

TESTING

- 1) Using 12 volt test lamp, check rotor continuity at slip rings and absence of ground between slip ring and rotor shaft. With ohmmeter, check for resistance of 4.0 to 4.4 ohms between slip rings.

- 2) Check resistance of .14 to .16 ohms between stator wires with ohmmeter. Check that windings are not grounded and have winding continuity with 12 volt test lamp.

- 3) Check diodes for continuity (approximately 60 ohms) in one direction only. If no continuity is observed in either direction, diode is open. If continuity is observed in both directions, diode is shorted. Rectifier assembly must be replaced if open or shorted diodes are found.

REASSEMBLY

- 1) Install bearing and retainer in front housing. Install rotor in housing to stop-ring, then install spacer, fan, pulley and nut with lock washer.
- 2) Assemble brush holder with brushes and springs, holding brushes in retracted position by inserting length of wire (paper clip) in holder. Solder leads from stator to rectifier pack and reverse disassembly procedure noting that scribe marks are aligned.
- 3) Remove brush retracting wire (paper clip) and seal hole with waterproof cement. Install and test alternator.

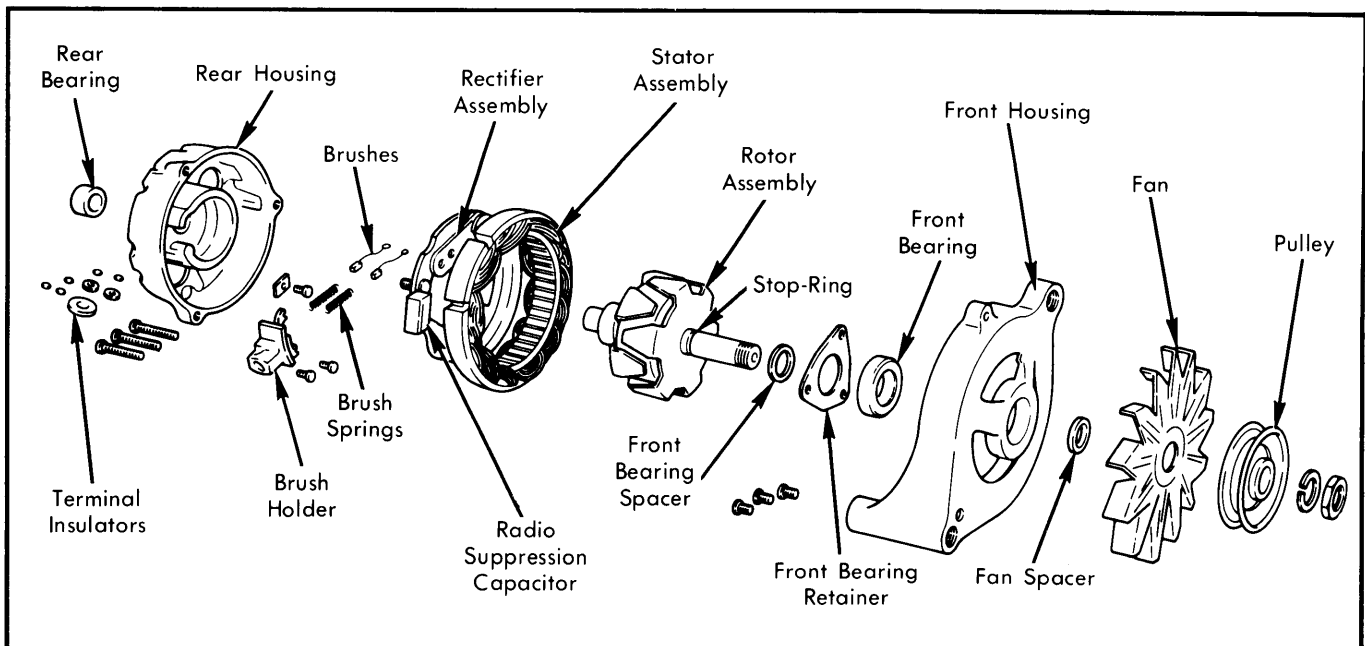

Fig. 2 Exploded View of Motorcraft Alternator