

## MARELLI ALTERNATORS

**Fiat**  
**All Models**

**NOTE** — Some models may be equipped with Bosch alternators.

### DESCRIPTION

Marelli alternators are conventional three-phase, self-rectifying type alternators. Six silicone rectifier diodes are connected to form a full-wave, three phase rectifying bridge. The three negative rectifier diodes are pressed directly in the end frame. Three positive diodes are located in a heat sink which is insulated from the end frame.

### APPLICATION

Model	Fiat No.
124 .....	A 12M 124/12/42M
128, 131 & X1/9 .....	A 124/14V/53A

### TROUBLE SHOOTING

#### INDICATOR LIGHT ON WITH IGNITION SWITCH IN OFF POSITION

Output current and voltage will be slightly lower than specifications. One or more positive diodes are shorted.

#### INDICATOR LIGHT ON AT LOW RPM

Stator winding has a phase open.

#### NO OUTPUT VOLTAGE

Rotor winding is open.

#### INDICATOR LIGHT ON WITH ENGINE RUNNING

One or more negative and energizing diodes shorted.

#### HIGH OUTPUT VOLTAGE

One energizing diode open. Improper operation of voltage regulator.

#### INDICATOR LIGHT GLOWS DIMLY WITH KEY ON OR ENGINE RUNNING

Faulty connection in ignition system. Brushes stuck in housing or worn excessively.

### TESTING

#### ASSEMBLED ALTERNATOR

**Rotor Windings** — Connect ohmmeter leads to positive blade brush holder (terminal 67) and a good ground. Resistance of 2.5-2.7 ohms should be noted at 68°F. Extremely high resistance indicates possible open circuit in rotor windings.

**Stator Phase Windings** — Check resistance at stator winding connectors. Resistance should be near zero. Extremely high resistance indicates open circuit in one or more windings.

**Diode Checks** — 1) Connect leads of an ohmmeter to terminal 30 and stator winding connector. Check resistance, then reverse leads and recheck. Both readings should show high resistance with one reading being slightly higher than the other. If both readings are low, a positive diode is bad.

2) Check resistance between ground and stator winding connector. Reverse leads and check reading. If both readings are low, a negative diode is bad.

3) Check resistance between energizing diode plug and stator winding connector. Reverse leads and check reading. If both readings are low, an energizing diode is bad.

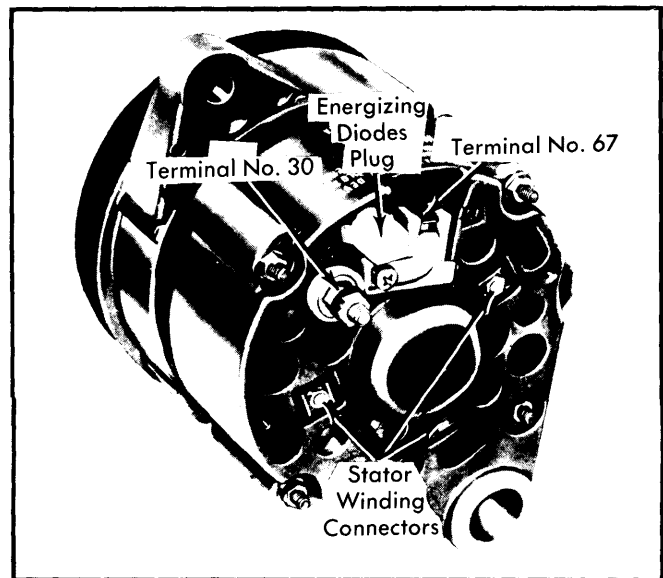

**Fig. 1 Marelli Alternator Test Points**

### OVERHAUL

#### DISASSEMBLY

- 1) Remove drive and ventilation components from rotor shaft. Remove brush holder (with brushes) by backing out its mounting screw on diode end head. Remove Woodruff key on shaft.
- 2) Unscrew nuts of the four through bolts, remove drive end frame and rotor. Before removing stator, unscrew from inside (of housing), three nuts securing stator winding phase ends to diode ends. Remove stator.
- 3) To disassemble diode end frame, unscrew the nut of terminal "30". The frame with negative diodes and the support with positive diodes will thus be separated.

#### TESTING

**Stator Winding Resistance** — With stator disassembled from alternator and leads disconnected, connect ohmmeter probes between each pair of stator leads. Ohmmeter must show equal readings for each pair of stator leads. Replace stator if readings are not equal.

**Rotor Winding Resistance** — Check rotor resistance with ohmmeter leads on slip rings. Resistance should be 2.5-2.7 ohms at 68°F.

# Alternators & Regulators

## MARELLI ALTERNATORS (Cont.)

**Brushes** — The spring pressure on slip ring brushes should be about one pound (0.43 kg), with new brushes in operation position.

stalling holder assembly, clean all parts of grease and carbon dust, lubricate bearings with suitable grease (Fiat MR 3).

**REASSEMBLY**

The alternator is reassembled by reversing the order of disassembly procedure.

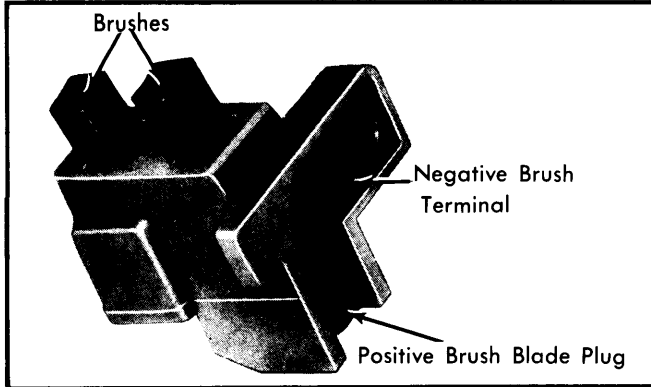

**Fig. 2 Brush Holder Assembly**

**PARTS REPLACEMENT**

**Brushes** — To ensure best results, brushes should be replaced with a new brush holder as a complete assembly. Before in-

**SPECIFICATIONS**

Application	Test Data
Cut-In-Speed (Max.) @ 12V (68°F)	1200 RPM
Current Output @ 14V	
A 12M 124/12/42M	44 amps. min.
A 124/14V/53A	57 amps. min.
Maximum Output Current	
A 12M 124/12/42M	53 amps.
A 124/14V/53A	70 amps.
Max. Cont. Alternator RPM	13,000

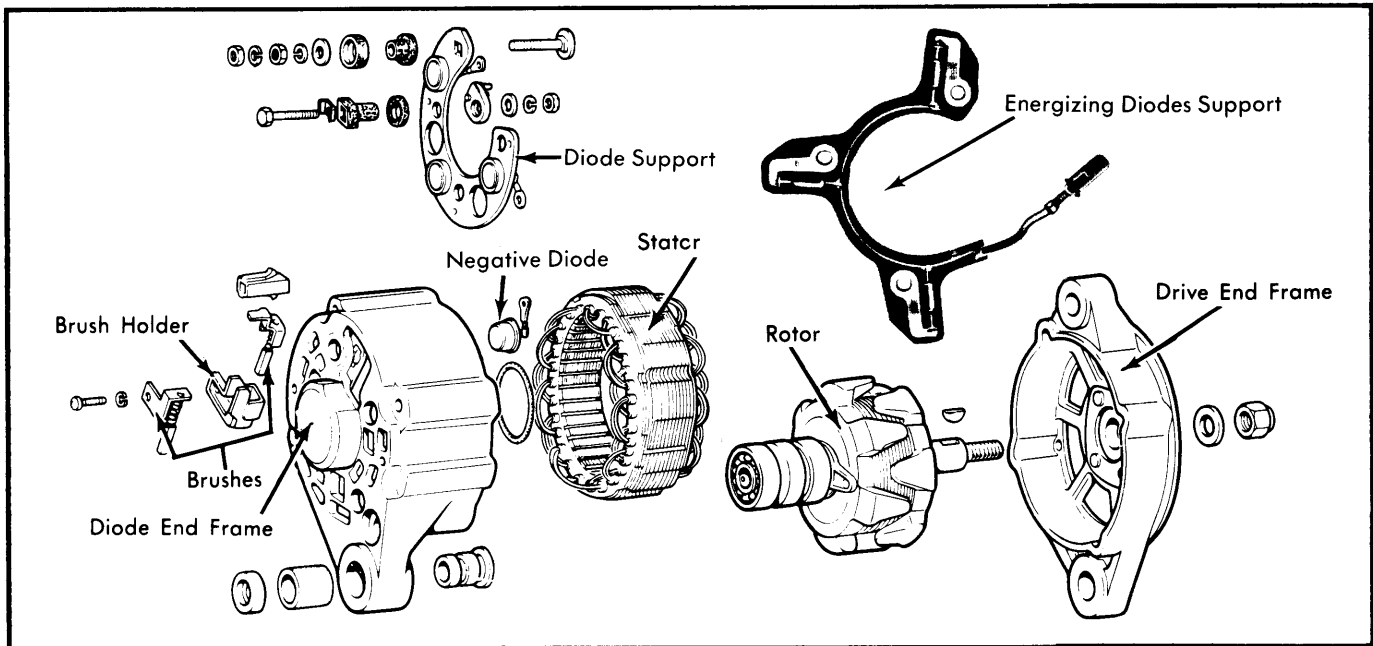

**Fig. 3 Disassembled View of Typical Marelli Alternator**